



Theses and Dissertations

2006-02-16

Measurement, Characterization, and Source Apportionment of the Major Chemical Components of Fine Particulate Material, Including Semi-Volatile Species

Brett D. Grover
Brigham Young University - Provo

Follow this and additional works at: <https://scholarsarchive.byu.edu/etd>



Part of the [Biochemistry Commons](#), and the [Chemistry Commons](#)

BYU ScholarsArchive Citation

Grover, Brett D., "Measurement, Characterization, and Source Apportionment of the Major Chemical Components of Fine Particulate Material, Including Semi-Volatile Species" (2006). *Theses and Dissertations*. 359.

<https://scholarsarchive.byu.edu/etd/359>

This Dissertation is brought to you for free and open access by BYU ScholarsArchive. It has been accepted for inclusion in Theses and Dissertations by an authorized administrator of BYU ScholarsArchive. For more information, please contact scholarsarchive@byu.edu, ellen_amatangelo@byu.edu.

MEASUREMENT, CHARACTERIZATION, AND SOURCE APPORTIONMENT OF
THE MAJOR CHEMICAL COMPONENTS OF FINE PARTICULATE MATERIAL,
INCLUDING SEMI-VOLATILE SPECIES

by

Brett D. Grover

A dissertation submitted to the faculty of

Brigham Young University

in partial fulfillment of the requirements for the degree of

Doctor of Philosophy

Department of Chemistry and Biochemistry

Brigham Young University

December 2005

Copyright © 2006 Brett D. Grover

All Rights Reserved

BRIGHAM YOUNG UNIVERSITY

GRADUATE COMMITTEE APPROVAL

of a dissertation submitted by

Brett D. Grover

This dissertation has been read by each member of the following graduate committee and by majority vote has been found to be satisfactory.

Date

Delbert J. Eatough, Chair

Date

Milton L. Lee

Date

David V. Deardon

Date

Paul B. Farnsworth

Date

C. Arden Pope

BRIGHAM YOUNG UNIVERSITY

As chair of the candidate's graduate committee, I have read the dissertation of Brett D. Grover in its final form and have found that (1) its format, citations, and bibliographical style are consistent and acceptable and fulfill university and department style requirements; (2) its illustrative materials including figures, tables and charts are in place; and (3) the final manuscript is satisfactory to the graduate committee and is ready for submission to the university library.

Date

Delbert J. Eatough
Chair, Graduate Committee

Accepted for the Department

David V. Deardon
Graduate Coordinator

Accepted for the College

Thomas W. Sederberg
Associate Dean, College of Physical and
Mathematical Science

ABSTRACT

MEASUREMENT, CHARACTERIZATION, AND SOURCE APPORTIONMENT OF THE MAJOR CHEMICAL COMPONENTS OF FINE PARTICULATE MATERIAL, INCLUDING SEMI-VOLATILE SPECIES

Brett D. Grover

Department of Chemistry and Biochemistry

Doctor of Philosophy

The promulgation of revised standards for atmospheric fine particles ($PM_{2.5}$) by the US EPA has sparked renewed interest in the ability to accurately measure and characterize suspended atmospheric particulate matter. Semi-volatile material (SVM), consisting of ammonium nitrate and semi-volatile organic material, is not accurately measured by EPA accepted methods such as the Federal reference method (FRM) or Tapered Element Oscillating Microbalance (TEOM). However, SVM is often a major fraction of urban aerosols.

Recent advances in atmospheric sampling instrumentation allowed for the semi-continuous characterization of urban $PM_{2.5}$, including SVM. The Filter Dynamic Measurement System (FDMS) was shown to measure total $PM_{2.5}$ mass including SVM. Validation of the FDMS was performed by comparison with the particle concentrator-Brigham Young University organic sampling system (PC-BOSS) and the real-time total ambient mass sampler (RAMS). Semi-continuous ambient particulate concentrations of

sulfate, nitrate and ammonium ion were measured by a newly developed Dionex instrument which was field tested and validated for the first time in Fresno, CA. Either a modified Sunset Laboratory carbon monitor, collocated with a conventional Sunset carbon monitor employing a common inlet, or the newly developed dual-oven Sunset monitor allowed for the semi-continuous determination of both nonvolatile and semi-volatile organic material.

This was the first attempt to characterize both nonvolatile and semi-volatile fractions of an urban aerosol in using all semi-continuous instruments. A suite of instruments for semi-continuous $PM_{2.5}$ monitoring was recommended including, an R&P FDMS for the measurement of $PM_{2.5}$ mass, a dual-oven Sunset monitor for the measurement of nonvolatile and semi-volatile carbonaceous species, and a Dionex GP-IC for the measurement of inorganic species. A TEOM monitor is also recommended to measure nonvolatile $PM_{2.5}$ mass. Using these instruments, semi-continuous mass closure was obtained for the first time during a study conducted in Riverside, CA.

The advantage of using semi-continuous sampler data in the application of source apportionment was elucidated. One-h averaged data applied to source apportionment models was shown to increase the power of the model to predict sources, both primary and secondary, that exhibit diurnal short-term episodes.

ACKNOWLEDGMENTS

Foremost I must acknowledge the help of my Heavenly Father in completing this work. I am grateful for Brigham Young University that allowed me to recognize His hand in my success.

As my research advisor, I thank Dr. Delbert Eatough for his assistance and guidance that he so freely afforded me during my studies at Brigham Young University. I also thank him for the many long hours he spent helping me in this pursuit and the confidence he showed in me. Also I am extremely grateful for the opportunities he gave me to be involved in so many great research projects.

As members of my graduate committee, I thank Dr. Paul Farnsworth, Dr. Milton Lee, Dr. David Dearden and Dr. C. Arden Pope for their advice and support in pursuit of my Ph.D.

I am extremely grateful for Dr. Norman Eatough who spent many long hours helping me with the research projects we performed. Also I thank him for the support and the kindness he showed me during my graduate studies.

I thank my family and friends for their support, love, and prayers during the last several years.

As members of the BYU atmospheric chemistry research group I would like to thank Dr. Russell Long, Dr. Kris Jaspering, Dr. William Modey, Dr. Lin Lin, Jeremy Richards, Mike Simpson, Cory Carter, Jon Bennion, Mike Kleinman, Woods Woolwine,

Phil Cannon, and Justin Cannon. Without their help, much of this work would not have been possible. Many of these people have become my good friends and I am indebted to them for all their help and support.

I am grateful for the help of many State agencies including the South Coast Air Quality Monitoring District, the California Air Resource Board, and the Utah Division of Air Quality. The help and support of Jeff Ambs, Rob Farber, William Wilson, Bob Carey, David Smith, Judy Chow and Scott Schellar are appreciated.

Finally, this work was funded by the U.S. Environmental Protection Agency and the National Science Foundation.

Contents

Abstract	v
Acknowledgments	vii
Contents	ix
List of Figures	xiii
List of Tables	xviii
Glossary	xx
Chapter 1. Introduction	1
1.1. Urban Pollution: A Historical Perspective	1
1.2. Urban Particulate Matter Overview	6
1.3. Size Distributions of Particulate Matter	6
1.4. Sources of Fine Particulate Matter	11
1.5. Effects of Fine Particulate Matter on Human Health	11
1.6. Effects of Fine Particulate Matter on Visibility	18
1.7. Effects of Fine Particulate Matter on Global Radiative Balance	20
1.8. National Ambient Air Quality Standards	21
1.9. Fine Particulate Matter Chemical Composition	23
1.10. Measurement of Fine Particulate Material	26
1.10.1. Pre-Sampling Components of a Fine Particulate Measurement System	26
1.10.2. Accuracy and Precision	33
1.10.3. The PM _{2.5} Federal Reference Method	34
1.10.4. The Measurement of Semi-Volatile Material	35
1.10.5. Fine Particulate Matter Monitoring Techniques	36
1.11. Goals of the Research	51
1.12. References	54
Chapter 2. Characterization and Source Apportionment of Fine Particulate Material in Urban Aerosols. Methodology and Project Information	62
2.1. Overview	62
2.2. Experimental	62
2.2.1. Integrated Monitoring Techniques	63
2.2.2. Semi-Continuous PM _{2.5} Mass Monitoring Techniques	68
2.2.3. Semi-Continuous Chemical Species Monitoring Techniques ...	81
2.2.4. Particle Size Distribution and Count	85
2.2.5. Gas Phase Data	88
2.3. Laboratory Analysis Methods	88
2.4. Source Apportionment of Ambient Aerosols	90
2.5. Data Analysis	94
2.6. References	95

Chapter 3. Monitoring and Source Apportionment of Fine Particulate Matter at Lindon, Utah	100
3.1. Overview	100
3.2. Experimental	101
3.2.1. Sampling Location	101
3.2.2. Sampling Methods	101
3.3. Results and Discussion	104
3.3.1. Data Trends and Comparisons	104
3.4. Source Apportionment Analysis	115
3.4.1. Approach	115
3.4.2. UNMIX Results Robustness	119
3.4.3. Comparison of UNMIX Results	122
3.5. Conclusions	128
3.6. References	129
Chapter 4. Measurement of Total PM_{2.5} Mass (Nonvolatile plus Semi-Volatile) with the FDMS TEOM Monitor	132
4.1. Overview	132
4.2. Sampling Methods	133
4.3. Sample Collection	136
4.4. Results	137
4.4.1. Lindon Study FDMS and RAMS Results.	137
4.4.2. Rubidoux Study FDMS, Differential TEOM, RAMS and GRIMM Results.	137
4.5. Discussion	147
4.6. Summary	153
4.7. References	156
Chapter 5. Source Apportionment of 1-h Semi-Continuous Data Using Positive Matrix Factorization with Total Mass (Nonvolatile plus Semi-Volatile) Measured by the R&P FDMS Monitor	159
5.1. Overview	159
5.2. Receptor Model Analysis	160
5.3. Data Collection and Analysis	161
5.4. Results	164
5.5. Discussion and Conclusions	173
5.6. References	174
Chapter 6. Measurement of Both Nonvolatile and Semi-Volatile Fractions of Fine Particulate Matter in Fresno, CA.	177
6.1. Introduction	177
6.2. Fresno Sampling Site	180
6.3. Sampling Methods	180
6.4. Sample Collection	183
6.5. Results	184

6.5.1. PC-BOSS Integrated Constructed Mass vs. Real-Time Total Mass Measurements	184
6.5.2. R&P FDMS vs FRM	187
6.5.3. Real-Time Mass Comparisons	189
6.5.4. Precision of Collocated R&P FDMS and R&P Differential TEOM Monitors	191
6.5.5. R&P FDMS vs R&P TEOM	192
6.5.6. R&P FDMS vs. R&P Differential TEOM	192
6.5.7. R&P FDMS vs. Met One BAM	193
6.5.8. R&P FDMS vs. Non-Heated and Heated GRIMM 1100 Monitor	193
6.5.9. Particulate Carbon Measurements	194
6.5.10. Inorganic Constituent Measurements	195
6.5.11. R&P FDMS and Constructed Real-Time Mass	201
6.5.12. SVM Comparison	203
6.6. Discussion	203
6.7. Conclusions	209
6.8. References	210

Chapter 7. Measurement of PM_{2.5} Nonvolatile and Semi-Volatile Organic

Material with the Sunset Laboratory Carbon Aerosol Monitor	216
7.1. Overview	216
7.2. Experimental	218
7.2.1. Measurement of Nonvolatile Carbonaceous Material with a Conventional Sunset Monitor and Semi-Volatile Carbonaceous Material with a Modified Sunset Monitor, Utilizing a Common Inlet	218
7.2.2. Sunset Monitor Modified to Measure Fine Particulate SVOC Lost from Particles During Sample Collection	218
7.2.3. The Dual-Oven Sunset Monitor for the Simultaneous Measurement of Nonvolatile and Semi-Volatile Carbonaceous Material	222
7.2.4. The PC-BOSS Sampler	223
7.2.5. Sample Collection	223
7.3. Results and Discussion	224
7.3.1. Efficiency of the Sunset Monitor Denuder for Removal of Gas Phase Organic Material	224
7.3.2. Determination of Fine Particulate SVOC and Nonvolatile Carbon with the Collocated Sunset Monitors Employing a Common Inlet	225
7.3.3. Evaluation of the Dual-Oven Sunset Monitor for the Simultaneous Measurement of Nonvolatile and Semi-Volatile Carbonaceous Material	230
7.3.4. Ambient Data Lindon, UT	233
7.3.5. Ambient Data Riverside, CA	235

7.3.6. Chamber Experiments with the Dual-Oven Sunset Monitor . . .	237
7.4. Conclusions	242
7.5. References	243
Chapter 8. Semi-Continuous Mass Closure of the Major Components of Fine Particulate Matter in Riverside, CA	246
8.1. Overview	246
8.2. Sampling Methods	248
8.2.1. Real-time PM _{2.5} Samplers	248
8.2.2. Sample collection	250
8.3. Results and Discussion	250
8.4. Conclusions	257
8.5. References	259
Chapter 9. Controlled Exposure Chamber Design for PM_{2.5} Exposure Studies	262
9.1. Overview	262
9.2. Experimental Methods and Procedures	264
9.2.1. Sampling Methods	264
9.2.2. Analytical Methods	265
9.3. Chamber Design	266
9.3.1. Exposure Facility	266
9.3.2. Aerosol Generation	267
9.3.3. Test Aerosols	267
9.4. Results and Discussion	269
9.4.1. Chemical Composition of a Photochemically Aged Aerosol in the Teflon Bag	270
9.4.2. Chemical Composition of the Aerosol in the Controlled Exposure Chamber Room	275
9.5. Summary	278
9.6. References	278
Chapter 10. Conclusions and Recommendations for Further Research	281
10.1. Overview	281
10.2. Conclusions and Recommendations for Further Research	282
10.3. References	287

List of Figures

Chapter 1

Figure 1.1.	Weakly mortality for greater London and estimated SO ₂ concentrations for the months surrounding the London fog episode.	5
Figure 1.2.	Schematic of size distribution, deposition and coagulation of particles.	9
Figure 1.3.	Estimated global mean radiative forcing by gases and aerosols in the year 2000 relative to 1750.	22
Figure 1.4.	Schematic representation of sampling artifacts on single filter samplers.	27
Figure 1.5.	Schematic representation of a typical virtual impactor.	29
Figure 1.6.	Schematic representation of a typical cyclone impactor.	31
Figure 1.7.	Schematic representation of a typical denuder used to separate gas-phase species from an aerosol.	32
Figure 1.8.	Fine particulate composition of aerosols in 7 U.S. cities determined by the PC-BOSS.	39
Figure 1.9.	PC-BOSS constructed mass vs FRM equilibrated mass for studies conducted at the Salt Lake City EMPACT site for both summer and winter sampling conditions.	43
Figure 1.10.	Three-h fine particulate species concentrations determined by the PC-BOSS for a 5 day period along the Wasatch Front.	45
Figure 1.11.	Comparison of fine particulate mass measured by the RAMS, TEOM, PC-BOSS and FRM in Riverside, CA. PC-BOSS concentrations are split into nonvolatile and semi-volatile fractions. Semi-volatile PM _{2.5} is measured by the RAMS and PC-BOSS but not by the conventional TEOM nor the FRM sampler.	47
Figure 1.12.	PC-BOSS constructed mass vs RAMS measured mass for studies conducted along the Wasatch Front from 1999-2001.	50
Figure 1.13.	RAMS vs TEOM measured mass concentrations for studies conducted along the Wasatch Front during the winter in Bountiful, UT (A) and during a winter (B) and a summer (C) in Hawthorne, UT.	52

Chapter 2

Figure 2.1.	Schematic of the sampling portion of PM _{2.5} Federal reference method.	64
Figure 2.2.	Schematic representation of the PC-BOSS.	66
Figure 2.3.	Schematic of the RAMS.	69
Figure 2.4.	Schematic of the microbalance portion of the R&P TEOM monitor.	73
Figure 2.5.	Schematic of the R&P Filter Dynamic Measurement System.	74
Figure 2.6.	Schematic of the R&P differential TEOM monitor.	76
Figure 2.7.	Schematic of the optical portion of the GRIMM monitor.	78
Figure 2.8.	Schematic of a typical b-ray attenuation device for the measurement of atmospheric particles.	80

Figure 2.9.	Schematic of the differential mobility analyzer cylinder model Long DMA 3081.	87
-------------	--	----

Chapter 3

Figure 3.1.	Location of the Lindon, Utah sampling site.	102
Figure 3.2.	Hourly-averaged TEOM monitor data obtain at the Lindon sampling site in August 2002. The data shown between the dotted lines were used for interpretation of the combined continuous sampler data set in this chapter.	105
Figure 3.3.	Average fine particulate composition over the study period (August 1 - August 26, 2002). Am, SV and NV represent ammonium, semi-volatile and nonvolatile respectively.	107
Figure 3.4.	Daily averaged fine particle composition during the time period of interest (August 16 - August 23, 2002). Am, SV and NV represent ammonium, semi-volatile and nonvolatile respectively.	108
Figure 3.5.	Hourly-averaged concentrations of TEOM monitor mass, RAMS mass, PM _{2.5} inorganic material, ammonium sulfate, ammonium nitrate, elemental carbon and gas phase compounds measured with the various continuous monitors.	111
Figure 3.6.	Comparison of PC-BOSS and semi-continuous sulfate.	112
Figure 3.7.	Comparison of PC-BOSS and semi-continuous nitrate.	114
Figure 3.8.	Comparison of RAMS and PC-BOSS constructed PM _{2.5}	123
Figure 3.9.	a) UNMIX identified primary emissions of sulfate, nitrate and TEOM primary mass from diesel emissions all follow the time pattern of EC, the dominant marker for this source. b) In contrast the primary species from auto emissions follow the concentrations of NO _x and precede the EC emissions by 1- to 2-h.	123
Figure 3.10.	The UNMIX identified secondary emissions of A) secondary daytime formation processes and B) secondary nighttime formation processes.	127

Chapter 4

Figure 4.1.	Data from the Lindon 2003 Study. 1-h average PM _{2.5} mass determined with the RAMS and FDMS in Lindon, UT during January and February, 2003.	138
Figure 4.2.	Data from the Rubidoux July 2003 study. (A) Comparison of 1-h average FDMS and Differential TEOM PM _{2.5} mass measurements. (B) Comparison of 1-h average FDMS and RAMS PM _{2.5} mass measurements. (C) Comparison of 1-h average FDMS and 50 °C TEOM monitor PM _{2.5} mass measurements.	141
Figure 4.3.	Comparison of 1-h average PM _{2.5} mass determined with the FDMS and differential TEOM in Rubidoux, CA. The solid line is the regression slope with a zero intercept and the dashed line is the regression line with a calculated intercept.	142

Figure 4.4.	Comparison of mass measurements at Rubidoux, CA made with (A) a conventional GRIMM monitor and the FDMS and (B) a GRIMM monitor equipped with a heated inlet and a TEOM monitor operating at 50 °C.	144
Figure 4.5.	Difference between the FDMS and GRIMM monitor mass measurements (shown as FDMS-GRIMM) and %RH at Rubidoux, CA.	145
Figure 4.6.	Comparison of 3-h average $PM_{2.5}$ mass determined with the PC-BOSS and FDMS in Rubidoux, CA. The solid line is the regression slope with a zero intercept and the dashed line is the regression line with a calculated intercept. The four data points where the difference between the two measurements is greater than 3σ compared to the remaining data are indicated with a square data point, see text.	150
Figure 4.7.	Comparison of 24-h average $PM_{2.5}$ mass determined with the FDMS and the single filter $PM_{2.5}$ FRM sampler in Rubidoux, CA. The solid line is the slope =1.	152
Figure 4.8.	Data from the Rubidoux July 2003 study. The circles indicate 1-h average FDMS $PM_{2.5}$ mass, the squares the difference between 1-h average FDMS and 50 °C TEOM monitor $PM_{2.5}$ mass, and the bars 1-h average R&P $PM_{2.5}$ ammonium nitrate mass measurements.	154
Figure 4.9.	Data from the Rubidoux July 2003 study. The circles indicate 1-h average FDMS $PM_{2.5}$ mass, the squares the difference between 1-h average FDMS and 50 °C TEOM monitor $PM_{2.5}$ mass, and the bars the sum of 1-h average R&P $PM_{2.5}$ ammonium nitrate mass measurements and the modified Sunset monitor semi-volatile organic material (SVOM) mass measurements. This sum is indicated as SVM, semi-volatile material.	155

Chapter 5

Figure 5.1.	Semi-continuous monitor data including measurements of $PM_{2.5}$ mass, chemical species, and gas phase species.	163
Figure 5.2.	Comparison of $PM_{2.5}$ total mass (nonvolatile plus semi-volatile) measured by the FDMS and the $PM_{2.5}$ predicted mass by PMF2.	166
Figure 5.3.	Source profiles deduced by PMF2 from the semi-continuous monitoring data collected during July 2003 in Rubidoux, CA. Percent of FDMS concentrations are given on the right y-axis for the particulate species and gas-phase species contributions are given on the left y axis.	167
Figure 5.4.	Source contributions from the six sources obtained at the SCAQMD Rubidoux, CA sampling site.	169

Chapter 6

Figure 6.1.	Comparison of FDMS measured mass with 3-h PC-BOSS integrated mass.	185
Figure 6.2.	Comparison of R&P FDMS and R&P differential TEOM monitors. . .	188
Figure 6.3.	Real-time mass monitor data for R&P FDMS vs R&P differential TEOM (A), MetOne BAM (B) and conventional GRIMM monitor and heated GRIMM monitor (C).	190
Figure 6.4.	Real-time concentrations of nitrate, sulfate and ammonium ions determined by the Dionex GP-IC system. R&P nitrate concentrations and R&P sulfate concentrations are included. Also shown are data from the Sunset carbon monitor and the R&P 5400 carbon monitor. Note that X-axis concentrations are different for each graph.	197
Figure 6.5.	Comparisons of 1-h average measurements of the anions (nitrate + sulfate) and the ammonium cation with the Dionex GP-IC system. . . .	200
Figure 6.6.	R&P FDMS vs constructed mass. Constructed mass consists of Dionex GP-IC nitrate and sulfate data represented as the ammonium salts, and Sunset carbon data.	202
Figure 6.7.	Comparison of the amount of SVM lost From the TEOM monitor (FDMS-TEOM) and that collected on the respective filters of the PC-BOSS (PC-BOSS SVM). Also shown are the 3-h averaged $PM_{2.5}$ concentrations measured by the FDMS.	204
Figure 6.8.	R&P FDMS concentrations and relative humidity (%).	207
Figure 6.9.	R&P FDMS measurement with real-time nitrate concentrations identifying varying composition in SVM at different time periods in the study.	208

Chapter 7

Figure 7.1.	Schematic of collocated conventional and modified Sunset monitors employing a common inlet.	219
Figure 7.2.	Measurement of (A) nonvolatile fine particulate carbonaceous material with a conventional Sunset Laboratory carbon aerosol monitor, and (B) SVOC lost from fine particles during sampling with a Sunset monitor modified as described in the text.	221
Figure 7.3.	Concentrations of nonvolatile fine particulate carbonaceous material determined with a conventional Sunset Laboratory carbon aerosol monitor, and SVOC lost from the collected fine particles during sampling determined with a Sunset monitor modified as described in the text.	226
Figure 7.4.	Comparison of SVOC, NVOC and $PM_{2.5}$ C measured with a Sunset monitor modified as described in the text and 3-h integrated data measured with a PC-BOSS.	228

Figure 7.5.	Dual-oven blank concentrations measured with three different blank configurations in Lindon, UT.	232
Figure 7.6.	Dual-oven Sunset monitor concentrations of NVOC, EC, and SVOC during July-August, 2005 in Riverside, CA.	236
Figure 7.7.	Comparison of dual-oven Sunset and PC-BOSS TC (NVOC + SVOC) for the study conducted in Riverside, CA, during July-August, 2005. Five statistical outliers ($> 3s$) were removed shown in squares in the figure.	238

Chapter 8

Figure 8.1.	Semi-continuous measurements of $PM_{2.5}$ mass and chemical species. (A) $PM_{2.5}$ mass measurements with the R&P FDMS and TEOM monitors, (B) inorganic sulfate and nitrate measured by the IC based sampler (C) non-volatile organic carbon and semi-volatile organic carbon measured by the dual-oven Sunset monitor, and (D) EC comparison between the dual-oven Sunset monitor and an Anderson Aethalometer.	251
Figure 8.2.	Constructed mass vs. FDMS measured mass. Constructed mass is the sum of all the major components of the aerosol including; NVOM, SVOM, NH_4NO_3 and ammonium sulfate.	256
Figure 8.3.	Comparison of SVM ₄ determined by the FDMS-TEOM with the sum of SVOM, measured by the dual-oven Sunset monitor, and NH_4NO_3 measured by the IC sampler.	258

Chapter 9

Figure 9.1.	Schematic of controlled exposure chamber facility at Brigham Young University.	268
Figure 9.2.	Normalized RAMS, TEOM and normal decay data for wood smoke in the Teflon bag.	271
Figure 9.3.	Chemical composition of a wood smoke aerosol in the Teflon bag including RAMS, TEOM and BOSS data. Pie graph area is relative to PM concentration. Concentrations are given in g/m^3	272
Figure 9.4.	Second exposure study of the chemical composition of wood smoke in the Teflon bag. Total PM concentrations are given in g/m^3	274
Figure 9.5.	BOSS obtained data of the chemical composition of fresh wood smoke in the controlled exposure room. Total PM concentrations are given in g/m^3	276
Figure 9.6.	Chemical composition of a wood smoke aerosol in the Teflon bag and subsequent composition when moved into the controlled exposure room. Pie graph area is relative to PM concentration.	277

List of Tables

Chapter 1

Table 1.1.	Comparison of Ambient Particles, Fine Particles and Coarse Particles .	12
Table 1.2.	Respiratory Penetration vs. Particle Size	13
Table 1.3.	Mortality Risk Ratios and 95% Confidence Intervals for Air Pollution from the Harvard 6-Cities and ACS Prospective Cohort Studies.	17
Table 1.4.	National Ambient Air Quality Standards for Designated Criteria Pollutants set by the United States Government.	24
Table 1.5.	Linear Regression Statistics for the Studies Conducted with Instruments Developed at Brigham Young University for the Measurement of Nonvolatile and Semi-Volatile Particulate Matter.	42

Chapter 3

Table 3.1.	Regression Statistics for Sulfate and Nitrate Comparison.	110
Table 3.2.	UNMIX Source Composition of Sources Normalized for Primary PM _{2.5} TEOM Monitor Mass.	117
Table 3.3.	UNMIX Source Compositions of Sources Normalized for Ammonium Sulfate.	120
Table 3.4.	UNMIX Source Composition of Sources Normalized for Nitrate.	121
Table 3.5.	Average Source Compositions for Diesel and Automobile Emissions. .	125

Chapter 4

Table 4.1.	Results of the Statistical Analysis of PM _{2.5} Measurements During the Lindon and Rubidoux Studies.	139
------------	---	-----

Chapter 5

Table 5.1.	Source Concentration Profiles for the Six Identified Sources with the Contribution of the Respective Chemical Species to the Source Mass.	168
------------	---	-----

Chapter 6

Table 6.1.	Linear Regression Analysis Results of the R&P FDMS (X) Compared to Other Real-Time Mass Measurement Instruments.	186
Table 6.2.	Results of Linear Regression Analysis for Fine Particulate Chemical Species.	196

Chapter 7

Table 7.1.	Linear Regression Statistics of PC-BOSS and Sunset Comparisons Including TC, SVOC, and NVOC in Rubidoux, CA with Collocated Sunset Monitors Employing a Common Inlet.	229
Table 7.2.	Dual-Oven Sunset Monitor Chamber Experiment Results.	240

Chapter 8

Table 8.1.	Linear Regression Statistics for Comparisons Made During the Riverside Study.	254
------------	---	-----

Glossary

ACS = American Cancer Association

BAM = Beta attenuation mass monitor

BIG BOSS = High volume-Brigham Young University organic sampling system

BOSS = Brigham Young University organic sampling system

BYU = Brigham Young University

b_{ext} = extinction coefficient

b_{sp} = scattering coefficient

CAA = Clean Air Act

CARB = California Air Resource Board

C_{comp} = individual chemical component concentration

$C_{\text{comp},\text{sf}}$ = side flow component concentration

CIF = Carbon impregnated cellulose filter

CIG = Charcoal impregnated glass fiber filter

C_{min} = Amount of the chemical component on the minor flow filter

C_o = Concentration of gas at the denuder entrance

CPC = Condensation particle counter

C_a = Cunningham aerodynamic diameter slip factor

C_p = Cunningham Stokes diameter slip factor

C_{sf} = Amount of the chemical component on the side flow filter

$C_{\text{sulfate},\text{min}}$ = Average minor flow sulfate concentration

$C_{\text{sulfate},\text{sf}}$ = Side flow sulfate concentration

C_x = Concentration of gas at distance (x)

D_{50} = Cyclone Impactor 50% cut-point

D_a = Aerodynamic diameter

D_p = Stokes Diameter

D_g = Geometric Diameter

D_x = Diffusion coefficient

DMA = Differential mobility analyzer

e = Elemental charge

EC = Elemental carbon

ECG = Echocardiogram

Eff_{pc} = Particle concentrator efficiency

f(RH) = Relative humidity function

FDMS = Filter Dynamics Measurement System

FRM = Federal reference method

GP-IC = Dionex gas-particle ion chromatographic instrument

HR = Heart rate

HRV = Heart rate variability

IACP = Integrated air cancer project

IPCC = Intergovernmental Panel on Climate Change

IC = Ion chromatography

k = Shape Factor for a Particle

LED = Light emitting diode

LOD = Limit of detection

m = Mass of the active part of the oscillator

Mm^{-1} = Inverse megameters

N = Number of samples

NAAQS = National ambient air quality standards

NDIR = Non-dispersive infrared absorption

NOAA = National Oceanic and Atmospheric Administration

NVM = Non-volatile material

NVOC = Nonvolatile organic carbon

NVOM = Nonvolatile organic material

NRDC = Nature Resource Defense Council

OC = Organic carbon

OM = Organic material

PAH = Polycyclic aromatic hydrocarbons

PC-BOSS = Particle concentrator-Brigham Young University organic sampling system

PIXE = Proton induced x-ray emission

PM = Particulate matter

PM_{10} = Particulate matter smaller than 10 μm

$PM_{2.5}$ = Particulate matter smaller than 2.5 μm

PMF = Positive matrix factorization

Q = Volumetric flow rate

Q_{min} = Virtual impactor minor flow

$Q_{min,fp}$ = Flow through the minor flow filter pack

$Q_{min,pc}$ = Particle concentrator minor flow

Q_{sf} = Flow through the side flow filter pack

Q_{tot} = Virtual impactor total flow

$Q_{tot,pc}$ = Particle concentrator total flow

R&P = Rupprecht & Patashnick

R^2 = Correlation coefficient

RAMS = Real-time total ambient mass sampler

RH% = Percent relative humidity

SCAQMD = South Coast Air Quality Monitoring District

SCC = Sharp cut cyclone

SES = Sample equilibration system

SMPS = Scanning mobility particle sizer

SOAR = Study of organic aerosols in Riverside

SOPM = Secondary organic particulate material

S_0 = Solar constant

STAR = Science to achieve results

SVM = semi-volatile material

SVOC = Semi-volatile organic carbon

SVOM = Semi-volatile organic material

T = Temperature

TC = Total carbon

TEA = Triethanolamine

TEOM = Tapered element oscillating microbalance

TOR = Thermo optical reflectance

TOT = Thermal optical transmittance

TPV = Temperature programmed volatilization

TTU = Texas Tech University

U.S. EPA = United States Environmental Protection Agency

UV = Aethalometer UV channel result

ω = Frequency of vibration

VOC = Volatile organic compounds

WINS = Well-Impaction Ninety-Six

x = Distance

XRF = X-ray fluorescence

Z_p = electrical mobility of a particle in a charged field

ρ_p = Density of a particle

ρ_0 Reference density of a particle

I = γ -rays intensity through a loaded filter

I_0 = γ -ray intensity through a clean portion of a filter

σ = Standard deviation

σ_r Relative standard deviation, percent precision

Chapter 1. Introduction

1.1. Urban Pollution: A Historical Perspective

Peacefully nestled on the hillside adjacent to the Monongahela River rests a small town named Donora, PA. Most people are unaware of Donora and the tragic events that occurred there in 1948. Standing erect near the center of the town is a small five-foot square plaque which reads:

The 1948 Donora Smog

Major clean air laws became a legacy of this environmental disaster that focused national attention on air pollution. In late October of 1948, a heavy fog blanketed this valley, and as the days passed, the fog became a thick, acrid smog that left about 20 people dead and thousands ill. Not until October 31 did the Donora Zinc Works shut down its furnaces-just hours before rain finally dispersed the smog (Davis, 2002).

Today, few remnants remain of the mills whose emissions once blanket the town and the surrounding areas. The green hills surrounding the small town create a picturesque scene of small town America. One would scarcely surmise that during the mid 1900's little vegetation would grow upwind of the local mills, leaving the valley hills with a dismal brown desert appearance. Few of the younger generations remember or may know of their town's infamy, but accounts by those who witnessed the events that occurred in October of 1948 are vivid and scaring.

During Donora's prime, coal-fired barges would snake up the Monongahela River delivering the necessary ingredients to feed the demand of the eternally operating steel mills. Often during the fall and winter months in the Ohio River valley, cool air

trickles down the surrounding hills becoming trapped in the valley by overarching warm air masses. These inversion conditions restrict the movement of air out of the valley, trapping all emitted smoke and pollution. These were the atmospheric conditions that buffeted the folks of Donora on October 26, 1948. As the mills continued to belch smoke into the valley, nothing could escape the clutches of the inversion layer. Berton Roueche, a writer for *The New Yorker*, depicted the conditions this way:

The fog closed over Donora on the morning of Tuesday, October 26th. The weather was raw, cloudy, and dead calm, and it stayed that way as the fog piled up all that day and the next. By Thursday, it had stiffened adhesively into a motionless clot of smoke. That afternoon, it was just possible to see across the street. Except for the stacks, the mills had vanished. The air began to have a sickening smell, almost a taste...(Davis, 2002).

At the height of the smog people couldn't see across the street to walk or drive their cars, spectators at the high school football game could not see the players or the ball, and firemen canvassed the city delivering short breaths of air from oxygen tanks. Many people fell ill, and the local doctor advised the sick to leave the city and escape to a park above the inversion layer. Those that did were reported to recover rapidly. It wasn't until November 1 that rains started to clear the thick black smoke that choked the city. By that time, the morgue had run out of caskets and the dead bodies were being stored in the basement of the community center. Although twenty people died during the week of the "killer smog" in Donora, the total effects on the people exposed in terms of reduced lifetime and health may never be accounted for. Donora, PA was a relatively small obscure town, even during its prime. However, the effects of a "killer smog" on a

major metropolitan area were observed several years later in London, England.

London, a major center for culture and learning in Europe, has an embattled history with epic air pollution. As early as the thirteenth century, as the city began to evolve into an expanding urban center, the city acquired the reputation for dirty, polluted air. Londoners, who had consumed most of the timber near the city for housing and heating, turned to coal for heating and industry. In fact, the coal had piled up in the streets of London. British trade vessels returning to the isle, to defy the stormy seas, would load their hulls full of what would later be branded “sea coal.” The detrimental effects of the smoke produced by the burning of the ready supply of coal was recognized as early as 1257 when Queen Eleanor issued the first ban on the burning of sea coal (Davis, 2002). This began a long history of ineffective bans on the burning of coal in the London area.

By the eighteenth and nineteenth centuries, Londoners were ruefully familiar with the dismal pollution caused by the constant burning of coal in the city. Commonly displayed in the works of artists during the time are glimpses into the dreary conditions that clouded the London area. Charles Dickens mercurially described the acrid smog that cursed the city in many of his novels and many of Monet’s most famous paintings were inspired by the effects of ambient light through the blight of smoke that often enslaved the city.

In early December 1952, frigid air settled in over the London area coercing the local citizens to huddle in their homes next to their coal-burning stoves. Elinor Grace Jones, a London pediatric nurse described the events as:

“[The fog was so thick that] we could not see across the street. It was the blackest and worst fog of any that I have ever seen. We wore masks inside the hospital. We had to change them every five minutes. They became so black. Even though I had quite a good knowledge of the streets of London and lived in the adjacent nurses’ residence a few hundred meters away, I could not find my way home” (Davis, 2002).

Pictures of London taken at noon during that week in December 1952 appear as if they were taken during the middle of the night. Even with the street lamps burning at full force, people could not see to walk. City buses, with their headlights operating, were guided down the streets by police officers on foot. In London 4,703 people died that week compared to 1,852 the same week the year before (Davis, 2002).

It wasn’t until many years later that scientists and epidemiologists began probing the data that lay hidden in the historical documents covering the London “killer smog” time period. Scientists discovered that not only did daily mortality rates spike during the week of the “killer smog,” but remained high for several weeks after the abnormally high concentrations of pollution dispersed, as shown in Figure 1.1. A comparison of daily mortality rates during the winter of 1952 between December and March with the same time period from other years, indicate that approximately 13,000 more people died than would be expected from historical averages (Bell and Davis, 2001).

Although the obscurity of Donora, PA left the smog episode that occurred there easy to ignore, London was one of the largest cities in the world during the 1950's. These events, and others similar, have ignited debates about the effects of anthropogenic emissions that are still burning today.

Figure 1.1. Weekly mortality for greater London and estimated SO₂ concentrations for the months surrounding the London fog episode.

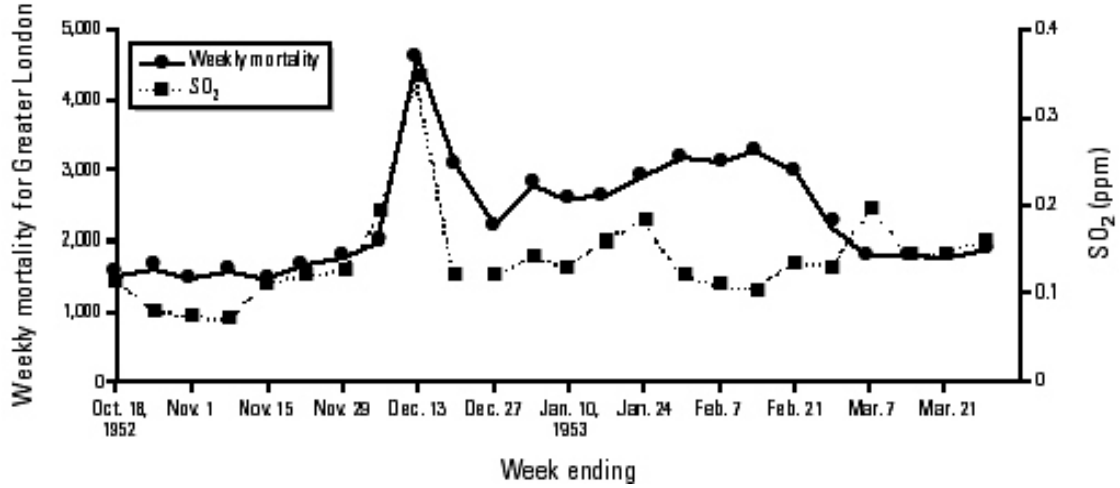

Adapted from Bell and Davis (2001)

1.2. Urban Particulate Matter Overview

One of the most explosive fields involved in the study of urban pollution is that of atmospheric particulate matter (PM). The chemical and physical properties of atmospheric PM are often complex and include a large variety of sizes, shapes, chemical, physical, and thermodynamic properties. Gasoline combustion, diesel combustion, manufacturing processes, mechanical processes, and biogenic emissions all contribute to atmospheric PM. Particles emitted directly from sources are referred to as primary while particles that are formed from atmospheric processes (i.e., photochemistry) or undergo a change in chemical composition following emission are called secondary. The term “aerosol” is used to describe suspended particles and all other gas-phase species that exist in an air mass. The term aerosol, however, is also often used to describe only the suspended particle fraction of an air mass. Ambient PM is not a single pollutant but is composed of a variety of chemical species including trace metals (including toxic, crustal, and transition metals), elemental carbon, nitrate, sulfate, and a variety of organic species.

1.3. Size Distributions of Particulate Matter

Atmospheric PM is often classified by the size of particles in the aerosol. Size distributions of particles become important when related to health effects, visibility, and climate change. For example, the scattering of sunlight in urban or pristine environments is highly dependent on the size distribution of the particles in the urban aerosol.

Therefore, a definition of particle diameter is essential, because atmospheric PM is highly morphologically variable. An “equivalent” diameter is used to describe PM, which defines the particle size by comparison with a spherical calibrated standard. There

are several ways to determine particle diameter, including light scattering, electron mobility, aerodynamic actions, and microscopy. The most commonly used definition of particle diameter is the *aerodynamic diameter*. Aerodynamic diameter (D_a) compares the terminal falling speed of the particle under consideration with a spherical particle that has a density of 1 g/cm³, and is given by the equation (Finlayson-Pitts and Pitts, 1999):

$$D_a = D_g k \sqrt{\frac{\rho_p}{\rho_0}} \quad (1.1)$$

where D_g is the geometric diameter, ρ_p is the density of the particle, ρ_0 is the reference density, and k is a shape factor ($k=1.0$ for a sphere). The size of PM is often defined by D_g because many of the instruments used to measure PM separate particles based on this definition. However, for particles less than 0.5 μm , the Stokes diameter (D_p) may be a more appropriate definition. The Stokes diameter is a comparison based on settling velocities described by the aerodynamic drag force imposed on a particle when the settling velocity of the particle is different from the surrounding substance (Finlayson-Pitts and Pitts, 1999). The Stokes diameter of a non-spherical particle would have the same settling velocity as an equivalent spherical particle. Therefore, the Stokes diameter does not account for the density of the particle. The aerodynamic diameter can be related to the Stokes diameter by:

$$D_a = \left(\frac{\rho_p C_p}{C_a} \right)^{1/2} D_p \quad (1.2)$$

where ρ_p is the particle density, D_a and D_p are the aerodynamic diameter and the Stokes diameter respectively, and C_a and C_p are the corresponding Cunningham slip factors.

A group of seminal papers on atmospheric size distributions of ambient particles was published by Whitby and co-workers (Whitby *et al.*, 1972a; 1972b; Whitby, 1978; Husar *et al.*, 1972) and described the measurement of over 1000 aerosol size distributions from locations across the United States. This was the first effort to extensively characterize atmospheric particle sizes with the fundamentals of the sources, removal processes, and chemical properties of different size particles addressed. Whitby observed that three “modes” or distinct groups of PM existed in the atmosphere, each of which can be characterized by different formation and removal processes, as illustrated in Figure 1.2.

The largest mode includes particles in the range of 2.5 μm - 30 μm and is called the coarse particle mode. Coarse particles are generated mostly by physical or mechanical processes and normally settle out of the atmosphere relatively quickly. Furthermore, the chemical composition of coarse particles is normally dominated by inorganic material such as sand or sea salt components.

Particles less than 2.5 μm in aerodynamic diameter ($\text{PM}_{2.5}$) are called fine particles. The fine particle mode consists of a large majority of the total particle number and also a large fraction of particle mass ($\sim 1/2$ in urban and $1/3$ in rural aerosols) in the atmosphere. These fine particles can remain suspended in the atmosphere for long time periods.

Figure 1.2. Schematic of size distribution, deposition and coagulation of particles.

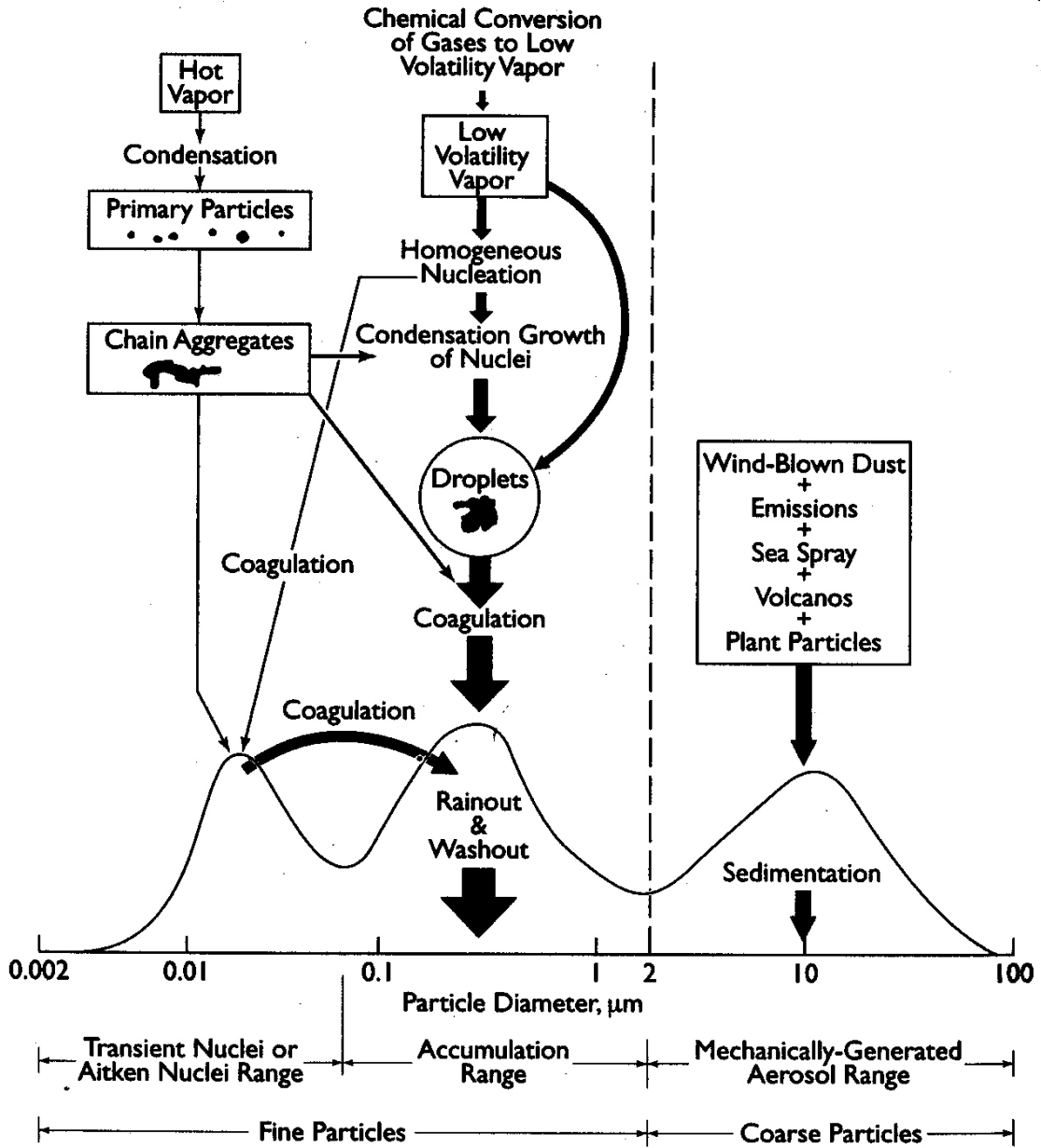

Adapted from Whitby and Sverdrup (1980).

The formation and growth of fine particles can occur via a variety of mechanisms. Coagulation of two particles can occur to form one particle. Gas-phase material can nucleate to form a particle as the gases in an emission source cool. The growth of particles can occur as gas-phase material condenses on existing particles. Gas-phase condensation on particles is preferential to smaller sized particles, and the coagulation of two particles is also a function of the size of the particles with lower rate constants observed as the particles become larger. Therefore, there is little or no growth of fine particles into the larger coarse particle mode.

The fine particle mode is therefore divided into two subsets consisting of particles between 0.15 and 2-3 μm called the accumulation mode and particles between 0.015 and 0.04 μm called the nuclei mode. As illustrated in Figure 1.2, the accumulation mode is generally formed by condensation and coagulation of small particles and gas-phase vapors. The nuclei mode occurs due to nucleation of particles, as well as condensation and coagulation. These fine particles are chemically different from their coarse particle counterparts, mainly consisting of chemical species resulting from combustion, including high concentrations of organic material and soluble inorganic species (i.e., sulfate and nitrate). Because fine particles are more relevant than coarse particles with respect to effects on health, visibility, and climate change, more attention has been focused in recent years on $\text{PM}_{2.5}$ than PM_{10} (particles with aerodynamic diameter less than 10 μm).

1.4. Sources of Fine Particulate Matter

Sources of atmospheric PM include both biogenic and anthropogenic emissions. Emissions from trees and other biogenic species occur naturally and include terpenes and other volatile organic species. Anthropogenic, or man-made, emissions are caused by a variety of sources including both stationary and mobile sources. Stationary sources consist of factories, refineries, and other industrial sources. Mobile sources include automobile, diesel, and aircraft. Furthermore, biomass burning for fuel, heat, crops, etc. also contributes a substantial amount of anthropogenic emissions on a global scale. An overview of the sizes, sources, chemical composition, and other atmospherically relevant parameters of PM is given in Table 1.1. Primary aerosols are those that can be attributed to direct emission from a defined source (i.e., diesel and automobile exhaust). Secondary aerosols undergo some transformation (i.e., photochemistry or oxidation) after emission into the atmosphere. Urban aerosols consist of large fractions of both primary and secondary pollutants (Eatough *et al.*, 2003).

1.5. Effects of Fine Particulate Matter on Human Health

Exposure to fine particulate matter has been implicated as a contributor to adverse human health effects including increases in cardiovascular and pulmonary disease, which leads to elevated human mortality and morbidity (Pope, 2000; Schwartz *et al.*, 1996; U.S. EPA, 2002). The exacerbation of observed health problems is believed to be associated more closely with exposure to fine particles than exposure to coarse particles because fine particles penetrate deeper into the lung than coarse particles (Wilson and Spengler, 1996). Table 1.2 gives human respiratory penetration based on particle size.

Table 1.1. Comparison of Ambient Particles, Fine Particles and Coarse Particles

	Fine		
	Ultrafine	Fine	Coarse
Formation Processes:	Combustion, high-temperature processes, and atmospheric reactions		Break-up of large solids/droplets
Formed by:	Nucleation Condensation Coagulation	Condensation Coagulation Reactions of gases in or on particles Reactions of fog and cloud droplets in which gases have dissolved and reacted	Mechanical disruption (crushing, grinding, abrasion of surfaces) Evaporation of sprays Suspension of dusts Reaction of gases in or on particles
Composed of:	Sulfate Elemental Carbon Organic compounds with very low saturation vapor pressure at ambient temperature	Sulfate, Nitrate, Ammonium, and Hydrogen ions Elemental carbon Large variety of organic compounds Metals: compounds of Pb, Cd, V, Ni, Zn, Mn, Fe, etc. Particle bound water	Suspended soil or street dust Fly ash from uncontrolled combustion of coal, oil and wood Nitrates/chlorides from HNO ₃ /HCl Oxides of crustal elements (Si, Al, Ti, Fe) CaCO ₃ , NaCl, sea salt Pollen, mold, fungal spores Plant and animal fragments Tire, brake pad, and road wear debris
Solubility:	Probably less soluble than accumulation mode	Largely soluble, hygroscopic, and deliquescent	Largely insoluble and non-hygroscopic
Sources:	Combustion Atmospheric transformation of SO ₂ and some organic compounds High temperature processes	Combustion of coal, oil, gasoline, diesel fuel, wood Atmospheric transformation products of NO _x , SO ₂ , and organic compounds, including biogenic organic species High temperature processes	Resuspension of industrial dust and soil tracked onto roads and streets Suspension from disturbed soil (e.g., farming, mining, unpaved roads) Construction and demolition Uncontrolled coal and oil combustion Ocean spray Biological sources
Atmospheric half-life:	Minutes to hours	Days to weeks	Minutes to hours
Removal Processes:	Grows into accumulation mode Diffuses to raindrops	Forms cloud droplets and rain out Dry deposition	Dry deposition by fallout Scavenging by falling rain drops
Travel Distance:	<1 to 10s of km	100s to 1000s of km	<1 to 10s of km (100s to 1000s in dust storms)

Adapted from Wilson and Suh (1997)

Table 1.2. Respiratory Penetration vs. Particle Size

Particle Size	Respiratory Penetration
11 μ m and larger	Particles do not penetrate
7-11 μ m and larger	Particles penetrate nasal passages
4.7-7 μ m	Particles penetrate pharynx
3.3-4.7 μ m	Particles penetrate trachea and primary bronchi
2.1-3.3 μ m	Particles penetrate secondary bronchi
1.1-2.1 μ m	Particles penetrate terminal bronchi
0.65-1.1 μ m	Particles penetrate bronchioli
0.43- 0.65 μ m	Particles penetrate alveoli

Adapted from Wilson and Spengler (1996).

Among the main devices used to determine causal relationships between exposure to particulate matter and adverse human health effects are epidemiological studies. A major assumption made in epidemiological studies is that ambient PM concentrations can be used as a surrogate for human exposure. The majority of the existing epidemiological studies can be grouped into two main categories including acute exposure studies and chronic exposure studies.

Acute exposure studies consider short-term events in air pollution to deduce related health effects including mortality and morbidity. As mentioned previously, several historic events of epic air pollution have occurred including, but not limited to, the Donora, PA episode of 1948 and the London fog episode of 1952. An increase in daily death counts concurrent with increases of PM air pollution were observed in several studies (Schwartz, 1994; Dockery and Pope, 1994; Pope *et al.*, 1995a). These studies indicate that a near linear correlation between air pollution concentrations and mortality exists. Furthermore, no threshold limit of PM was observed in which concentrations of PM become unrelated to human mortality and morbidity. A “lead-lag” relationship between human mortality/morbidity and PM concentrations is often observed, in which death counts or hospitalizations are observed for several days following an episode of PM air pollution (Pope *et al.*, 2000).

If a causal relationship between PM concentrations and human mortality is observed, one would also expect to see a relationship between PM concentrations and human morbidity. However, this relationship is often more difficult to deduce because morbidity is a subjective health end point. Morbidity health end points, related to acute exposure to particulate air pollution, include hospital visits for respiratory illness, decline

in the measurement of lung function, increased incidences of asthmatic problems, and increased duration of respiratory sickness (Wilson and Spengler 1996). An influential study conducted on the relationship between particulate air pollution and human morbidity was conducted in Utah Valley, relating hospital visits to PM concentrations dominated by a local steel mill (Pope, 1989). During a winter when the steel mill was not in operation, children's hospital visits decreased by approximately 50% compared to adjacent years when the steel mill was in operation. Furthermore, this relationship was related to the concentrations of PM dominated by emissions from the steel mill.

Many acute exposure studies of human mortality and morbidity suggest that these health end points may be more closely related to PM caused by combustion than to that originating from natural sources (Schwartz *et al.*, 1996; Dockery *et al.*, 1992). Two factors may impact the observed differences between anthropogenic and naturally occurring particulate air pollution including: (1) combustion related particles fall into the size regime that will penetrate deep into the lung, and (2) the chemical composition of combustion related particles is much different from that of naturally occurring particles, as mentioned previously. In a study conducted in southeast Washington state, hospital visits for respiratory illness did not show a statistically significant relationship with high concentrations ($>1000 \text{ g/m}^3$, PM_{10}) of wind blown dust (Hefflin *et al.*, 1994).

Chronic exposure studies have used long-term data, normally more than one year, to deduce human mortality and morbidity for communities with different particulate air pollution concentrations and compositions. Whereas acute exposure studies look at episodes of high PM concentrations, chronic studies also include enduring exposure to

low and moderate levels of PM, as well as episodes of high concentrations of PM. The most advanced chronic exposure studies fall under the umbrella of prospective cohort studies, which give some of the most compelling evidence linking human mortality and morbidity with exposure to ambient PM. Two major studies have been conducted, including the Harvard six-cities study (Dockery *et al.*, 1993) and the American Cancer Association (ACS) 151-city study (Pope *et al.*, 1995b). These studies followed a cohort of people for several years accounting for age, sex, cigarette smoking, and occupation exposure in their regression models. The results of these studies on human mortality are given in Table 1.3. From these studies it was estimated that between 23,000 and 124,000 deaths per year occur in the United States directly from chronic exposure to air pollution (NRDC 1996).

The pathophysiological pathways linking ambient PM concentrations to human mortality and morbidity are not well understood. However, some indications of biological mechanisms are evident. Epidemiological studies suggest that observed health effects are most likely related to cardiopulmonary disease, including asthma, cardiopulmonary, and cardiorespiratory related health care visits, as well as death related to cardiac and pulmonary disease (Pope, 2000; Schwartz *et al.*, 1996). Furthermore, no relationships between non-cardiopulmonary disease were statistically evident (Pope, 2000). Some of the biological pathways linking particulate air pollution to cardiopulmonary disease are pollution induced lung damage, pulmonary inflammation, decline in lung function, respiratory distress, and potentially cardiovascular disease related to hypoxia (Pope, 2000). Links between inflammation stemming from particulate air pollution have been observed (Souza *et al.*, 1998; Seaton *et al.*, 1995; Pope *et al.*,

Table 1.3. Mortality Risk Ratios and 95% Confidence Intervals for Air Pollution from the Harvard 6-Cities and ACS Prospective Cohort Studies.

Particulate Air Pollution (Most vs Least-Polluted City)			
Cause of Death	6-Cities (PM _{2.5})	ACS (PM _{2.5})	ACS (SO ₄)
All	1.26 (1.08-1.47)	1.17 (1.09-1.46)	1.15 (1.09-1.22)
Cardio-pulmonary	1.37 (1.11-1.68)	1.31 (1.17-1.46)	1.26 (1.16-1.37)
Lung Cancer	1.37 (0.81-2.31)	1.03 (0.80-1.33)	1.36 (1.11-1.66)
All Others	1.01 (0.92-1.24)	1.07 (0.92-1.24)	1.01 (0.92-1.11)

Adapted from (Wilson and Spengler 1996)

2004) as well as decline in lung function (Pope *et al.*, 1992; 1991; Romieu *et al.*, 1996; Peters *et al.*, 1997; Vedal *et al.*, 1998). However, no associations between particulate pollution and hypoxemia have been found (Pope *et al.*, 1999).

More recently, attention has turned to the autonomic nervous system and cardiovascular related health effects. Cardiac death may be influenced by changes in blood viscosity, heart rate (HR), and heart rate variability (HVR) (Kennedy, 1997; Pope *et al.*, 2004). Blood coagulability may be influenced by injurious cytokines resulting from PM deposited in the lung alveoli (Seaton *et al.*, 1995). Recent toxicological studies with animals suggested that changes in cardiac autonomic function as a function of exposure to particulate air pollution are reasonable, and may occur within short time periods from exposure (Godleski *et al.*, 2000). Additionally, release of harmful cytokines, electrocardiogram abnormalities, and pulmonary inflammation have been observed during animal exposure studies (Godleski *et al.*, 1996; 1997; and 2000; Terashima *et al.*, 1997).

1.6. Effects of Fine Particulate Matter on Visibility

Atmospheric fine particles play a dominate role in the scattering and absorption of light transmitted through the atmosphere resulting in degradation of visibility. Visibility has often been defined as the “farthest distance at which a large black object can be distinguished against the horizon sky” (US EPA 2002). In the Clean Air Act (CAA) of 1977, congress established the goal of the “prevention of any further and remedying of any existing impairment of visibility in mandatory Class I Federal areas (many national parks and wilderness areas), which impairment results from manmade air pollution” (Title I Part C Section 169A, U.S. Code [1990]). The CAA amendments of

1990, furthermore, required the U.S. EPA to establish research on visibility degradation in Class I Federal areas, resulting in the establishment of the Regional Haze Rule (Federal Registry, 1999). The Regional Haze Rule promulgated the protection of 156 Class I areas and stipulated the establishment of baseline and long-term visibility tracking. These Congressionally mandated stipulations have led to a surge of interest to determine the relationship between anthropogenically emitted PM and visibility degradation.

The effect of air pollution on visibility is frequently determined by the light extinction coefficient (b_{ext}) or the amount of light scattered and absorbed by particles and gases, and given by the equation:

$$b_{\text{ext}} = b_{\text{ap}} + b_{\text{ag}} + b_{\text{sp}} + b_{\text{gp}} \quad (1.3)$$

where the subscripts a and s are absorption and scattering respectively, and the subscripts p and g represent particles and gases, respectively. In environments that are influenced by anthropogenic emissions, light extinction is dominated by particle scattering, accounting for 68 to 86% of b_{ext} in many California cities (Eldering *et al.*, 1994). The efficiency of light scattering by particles is dependent upon the composition, size, and solubility of the particles (Pryor and Steyn, 1994; Malm, 2000).

Aerosols that are highly hygroscopic often exhibit increased light extinction coefficients under high percent relative humidity (RH%) time periods, due to the uptake of water by particles. Relative humidity must be accounted for in aerosols that contain large amounts of hygroscopic chemical components such as ammonium nitrate. For particles with known chemical composition, models can be used to estimate the particle growth that occurs under specific %RH conditions (Saxena *et al.*, 1995; Pillinis, *et al.*,

1995). An estimate of the b_{ext} was proposed by Malm *et al.*, 2000 and can be calculated as:

$$\begin{aligned} b_{\text{ext}} = & (3) f(\text{RH}) [\text{Sulfate}] + \\ & (3) f(\text{RH}) [\text{Nitrate}] + \\ & (4) [\text{Organic Carbon}] + \\ & (10) [\text{Light Absorbing Carbon}] + \\ & (1) [\text{Soil Component}] + \\ & (0.6) [\text{Coarse PM}] + \\ & (10) (\text{for Rayleigh scattering by gases}). \end{aligned} \quad (1.4)$$

where each term consists of a dry extinction coefficient for the specific chemical species and the mass concentration for that chemical species. An adjustment factor is used for sulfate and nitrate to account for their hygroscopic nature (Malm *et al.*, 2000)

1.7. Effects of Fine Particulate Matter on Global Radiative Balance

The global radiative balance can be estimated by the amount of incident solar radiation on the planet and the amount of energy that is absorbed. The incoming solar energy (S_0), called the solar constant, as measured by the satellite NIMBUS-7 from 1980 to 1986, determined an average value of S_0 as 1370 W m^{-2} (Mecherikunnel *et al.*, 1988). The climate modeling community has denoted “radiative forcing” in W m^{-2} as the metric of the effects of natural and anthropogenic influences on the temperature of the troposphere (US EPA 2002). Components that reflect solar radiation back into space are assigned a negative forcing value while those that absorb solar radiation, or act to heat the tropospheric system, are assigned a positive value.

Ambient particles influence the global radiative balance in a variety of ways. As mentioned previously, light scattering of particles occurs and is dependent upon size, chemical composition, and the hygroscopic nature of the particles. Furthermore,

particulate chemical components such as black carbon and soil constituents act as absorbing species of incoming solar radiation. Because ambient particles are often composed of many chemical species, the dynamics of particle absorption and scattering are often extremely complicated and depend upon the size and mixing of the chemical species in the particles (Fuller *et al.*, 1999; Haywood and Shine, 1997).

Ambient PM also has an indirect effect on global radiative balance in addition to scattering and absorption. Aerosol particles act as cloud condensation nuclei to form water droplets in the atmosphere. The size of water droplets formed in a cloud is dependent upon the chemical composition and size of the particles. Therefore, smaller particles result in an increased number of water droplets formed, resulting in higher cloud albedo. The increase in cloud albedo from anthropogenic emitted particles has been estimated as a range from 0 to -2.0 W m^{-2} (IPCC, 2001). Furthermore, suppression of rainfall over polluted areas has been observed due to the decrease in cloud droplet radii to below the precipitation threshold (Rosenfeld, 1999).

The estimate of radiative forcing by man-made particles is, therefore, a complicated task derived from many uncertainties that exist in the multiple direct and indirect effects that particles have on climate change. Estimates of radiative forcing by gases and aerosols in the year 2000 relative to 1750 are shown in Figure 1.3.

1.8. National Ambient Air Quality Standards

Because of the adverse effects on human health, visibility, and global radiative balance, the U.S. Federal Government has classified both PM_{10} and $\text{PM}_{2.5}$ as *criteria pollutants* resulting in the establishment of National Ambient Air Quality Standards (NAAQS). The U.S. Government has designated seven pollutants as *criteria pollutants*

Figure 1.3. Estimated global mean radiative forcing by gases and aerosols in the year 2000 relative to 1750.

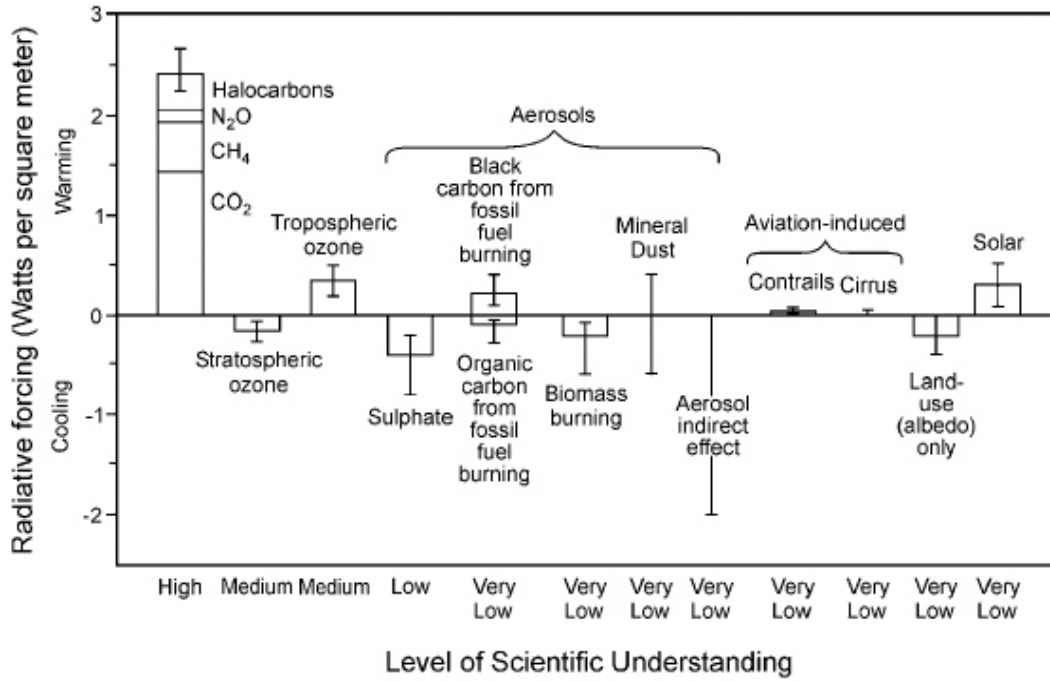

Adapted from IPCC (2000)

due to their documented effects on people, nature, or materials at concentrations often observed in urban areas, and has set NAAQS for each of them as shown in Table 1.4. Furthermore, the promulgation of revised standards for PM by the U.S. Environmental Protection Agency, which established new annual and 24-h fine particulate standards, has sparked renewed interest in the ability to accurately characterize and measure $PM_{2.5}$.

1.9. Fine Particulate Matter Chemical Composition

The recognition that ambient fine particulate matter is not a single pollutant, but a mixture of many chemical species, was an advancement in the understanding and control of atmospheric PM (Chow, 1995). Major components include: sulfate, nitrate, ammonium, and hydrogen ions; trace elements (including toxic and transition metals, e.g. Fe); organic material (both primary and secondary); elemental carbon; and crustal components.

Semi-volatile material (SVM) can be a significant portion of urban aerosols (Tang *et al.*, 1994; Ding *et al.* 2002a; Modey *et al.*, 2001; 2002; Ding *et al.*, 2002b; Lewtas *et al.*, 2001). Atmospheric semi-volatile species consist of those species that exist in dynamic equilibrium between the gas and particulate phase in the atmosphere and include particle bound water, ammonium nitrate, and semi-volatile organic compounds.

Several studies of atmospheric chemistry in urban environments have shown that a substantial fraction of the $PM_{2.5}$ in these environments is semi-volatile organic and nitrate material (SVM), (Eatough *et al.*, 2001; Long *et al.*, 2002; Long *et al.*, 2003). Furthermore, these studies have shown that the majority of the semi-volatile organic material (SVOM) is secondary (Eatough *et al.*, 2003). The formation processes of secondary PM in urban atmospheres is well understood for inorganic species such as

Table 1.4. National Ambient Air Quality Standards for Designated Criteria Pollutants set by the United States Government.

Primary			Secondary	
Pollutant	Concentration	Time	Concentration	Time
CO	9.0 ppm 35.0 ppm	8 h 1 h		
SO ₂	0.03 ppm 0.14 ppm	Annual average 24 h	0.5 ppm	3 h
O ₃	0.12 ppm 0.08 ppm	1 h 8 h	0.12 ppm 0.08 ppm	1 h 8 h
NO ₂	0.053 ppm	Annual mean	0.053 ppm	Annual average
Particulate Matter				
PM ₁₀	50 g/m ³ 150 g/m ³	Annual mean 24 h	50 g/m ³ 150 g/m ³	Annual mean 24 h
PM _{2.5}	15 g/m ³ 65 g/m ³	Annual mean 24 h	15 g/m ³ 65 g/m ³	Annual mean 24 h
Lead	1.5 g/m ³	Quarterly average	1.5 g/m ³	Quarterly average

Adapted from Finlayson-Pitts and Pitts (1999)

ammonium sulfate and ammonium nitrate. However, the mechanisms and kinetics of the formation of secondary organic species is not well understood.

Time periods of high photochemical activity promote atmospheric reactions resulting in secondary nitrate and sulfate. Gaseous nitric acid can be formed by the reaction of NO_2 with the OH radical during periods of high photochemical activity. SO_2 can also be converted to H_2SO_4 by reaction with the OH radical or by aqueous phase reactions with H_2O_2 , O_3 , or O_2 (Finlayson-Pitts and Pitts, 1999). Furthermore, HNO_3 and H_2SO_4 react with atmospheric ammonia to form ammonium salts (Finlayson-Pitts and Pitts, 1999).

Secondary organic particulate matter (SOPM) is formed from reactions involving volatile organic compounds (VOCs) that result in the formation of organic compounds with low vapor pressures under ambient conditions. The suite of reactions that occur to form SOPM are not well understood but include gas phase homogeneous chemistry (Seinfeld and Pandis, 1998) and may occur in aqueous aerosols including clouds and fogs (Graedel and Goldberg, 1983; Faust, 1994; Aumont *et al.*, 2000). Also, VOCs may coagulate to form secondary particles or condense on pre-existing particles. Reaction pathways for the formation of secondary organic aerosols are thought to be initiated by O_3 and the OH radical (Pun *et al.*, 2000; Pandis *et al.*, 1992). Several studies indicate that SVOM concentrations are highly correlated with ozone concentrations under conditions of high photochemical activity (Turpin *et al.*, 1991; Turpin and Huntzicker 1995; Grover and Eatough, submitted). However, reactions with other atmospheric radicals including HO_2 and NO_3 radicals may initiate the formation of SOPM (Pun *et al.*, 2000).

1.10. Measurement of Fine Particulate Material

The accurate measurement of urban particulate matter is a daunting task. The EPA's decision to revise standards has sparked renewed interest in the ability to accurately measure and characterize suspended atmospheric particulate matter. Measurement is complicated by the fact that ambient fine particulate matter is not a single pollutant, but a mixture of many chemical species including both nonvolatile and semi-volatile species. Furthermore, care must be taken to avoid sampling artifacts on filter samplers (Koutrakis and Sioutas 1996). Artifacts can lead to the overestimation (positive artifact) or underestimation (negative artifact) of particulate mass or composition. Positive artifacts arise from the sorption of gas-phase species such as SO_2 , HNO_3 and VOC's onto the collection filter. Negative artifacts can occur due to evaporative losses of SVM from particles collected on a filter, or particle interaction during or following sample collection. A schematic representation of sampling artifacts is given in Figure 1.4.

1.10.1. Pre-Sampling Components of a Fine Particulate Measurement System

Most sampling techniques employ one or more of several common pre-sampling components, including inlets (cyclone and virtual impactors), denuders, and dryers/heaters. These pre-sampling components are used to separate unwanted constituents of the aerosol from the particles of interest.

Inlets. Sampling inlets are commonly used to remove the coarse particle fraction from the fine particle fraction before sampling. These systems take advantage of particle inertia to separate particles above a given "cut-point" from the air stream.

Figure 1.4. Schematic representation of sampling artifacts on single filter samplers.

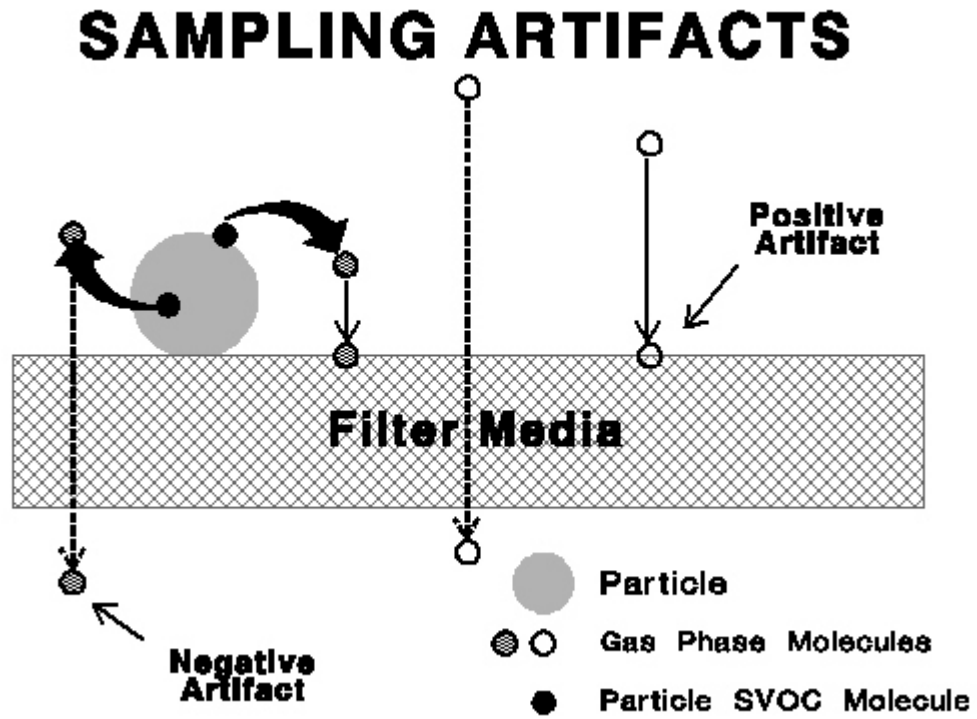

The most regularly used particle inertia separation devices are virtual, conventional, and cyclone impactors.

A schematic of a typical virtual impactor is given in Figure 1.5. In this method, the aerosol is directed to a collection probe via an acceleration nozzle. The collection probe is slightly larger in size than the acceleration nozzle. Particles larger than the cut-point of the impactor cross the air stream due to their inertia, and subsequently enter the minor flow collection probe. Smaller particles follow the major flow air stream and penetrate into the fine particle collection portion of the instrument. A minor flow (Q_{\min}), typically 10-20% of the total flow (Q_{tot}), is employed to direct the larger particles to the collection probe. If the cut point of the impactor is very small (i.e. $< 0.1 \mu\text{m}$), virtual impactors may be used as particle concentrators (Sioutas *et al.*, 1994; Eatough *et al.*, 1999; Ding *et al.*, 2001) because the concentration of particles in the minor flow is increased by a factor of Q_{tot}/Q_{\min} . Particles smaller than the cut-point and 80-90% of the gases are discarded (Sioutas *et al.*, 1994). However, one disadvantage of using a virtual impactor as a particle concentrator is that a small fraction of mass present in ultra-fine particles is lost through the major flow.

Conventional impactors operate in similar fashion to virtual impactors. However, instead of a minor flow to remove large particles and gases, an impaction surface is used. Particles greater than the impactors cut-point are impacted on a collection surface while smaller particles penetrate into the instrument. The impaction surface is often coated with a sticky material, such as vacuum grease, to avoid particle bounce. If particle bounce occurs, larger particles penetrate into the instrument. Conventional impactors are

Figure 1.5. Schematic representation of a typical virtual impactor.

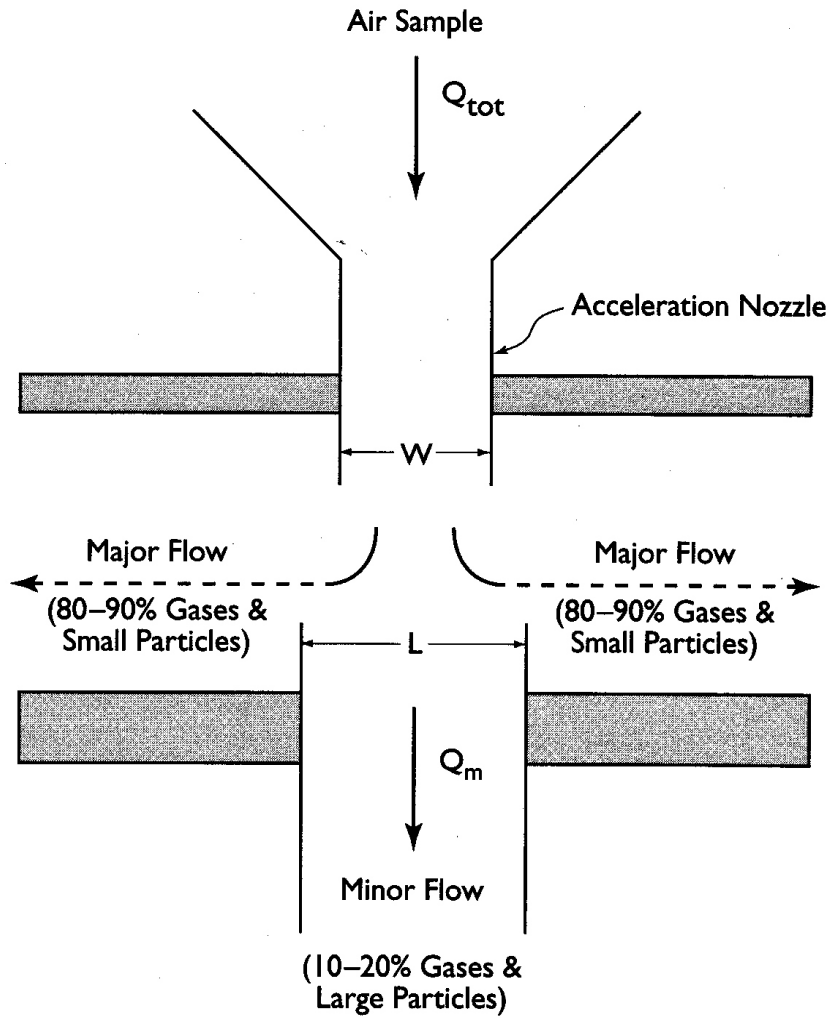

Adapted from Koutrakis and Sioutas (1996)

used in all PM_{2.5} Federal reference method (FRM) samplers to separate coarse particles from fine particles, prior to collection.

In a cyclone impactor, shown in Figure 1.6, the aerosol is drawn tangentially into the top of the cyclone. The cyclone body is used to create a double vortex in which the air stream spirals down towards the bottom at the outer portion of the cyclone. The air then redirects and spirals up the inner portion of the cyclone to the exit. Impaction of particles along the inner wall of the cyclone occurs for particles with sufficient inertia that are unable to follow the ascending path of the airstream. These particles fall to the bottom of the cyclone due to gravity and are removed (Chow, 1995). One disadvantage of cyclones is that the air stream is three-dimensional and therefore difficult to describe. However, the dependence of the cut-point on the flow rate can be described as:

$$D_{50} = K Q^n \quad (1.5)$$

where D_{50} is the 50% cut-point, Q is the flow rate through the cyclone, and n and K are constants dependent on the design of the cyclone (Chan and Lippman, 1977).

Denuders. To reduce positive artifacts caused by gas-phase absorption on collection media, denuders have been used to remove gas-phase components from the sampling stream prior to collection (Koutrakis *et al.*, 1993; Eatough *et al.*, 1993). Denuders function on the basis of the difference between diffusion coefficients for gases and particles as shown in Figure 1.7. As a laminar flow is pulled through a denuder, inertia will carry the particles through the denuder. However, gases with high diffusion coefficients will strike the walls of the denuder during the residence time of the aerosol through the denuder. If the surfaces of the denuder are reactive toward the gas, the gases are removed from the air stream. The depletion of gas-phase species as a function of

Figure 1.6. Schematic representation of a typical cyclone impactor.

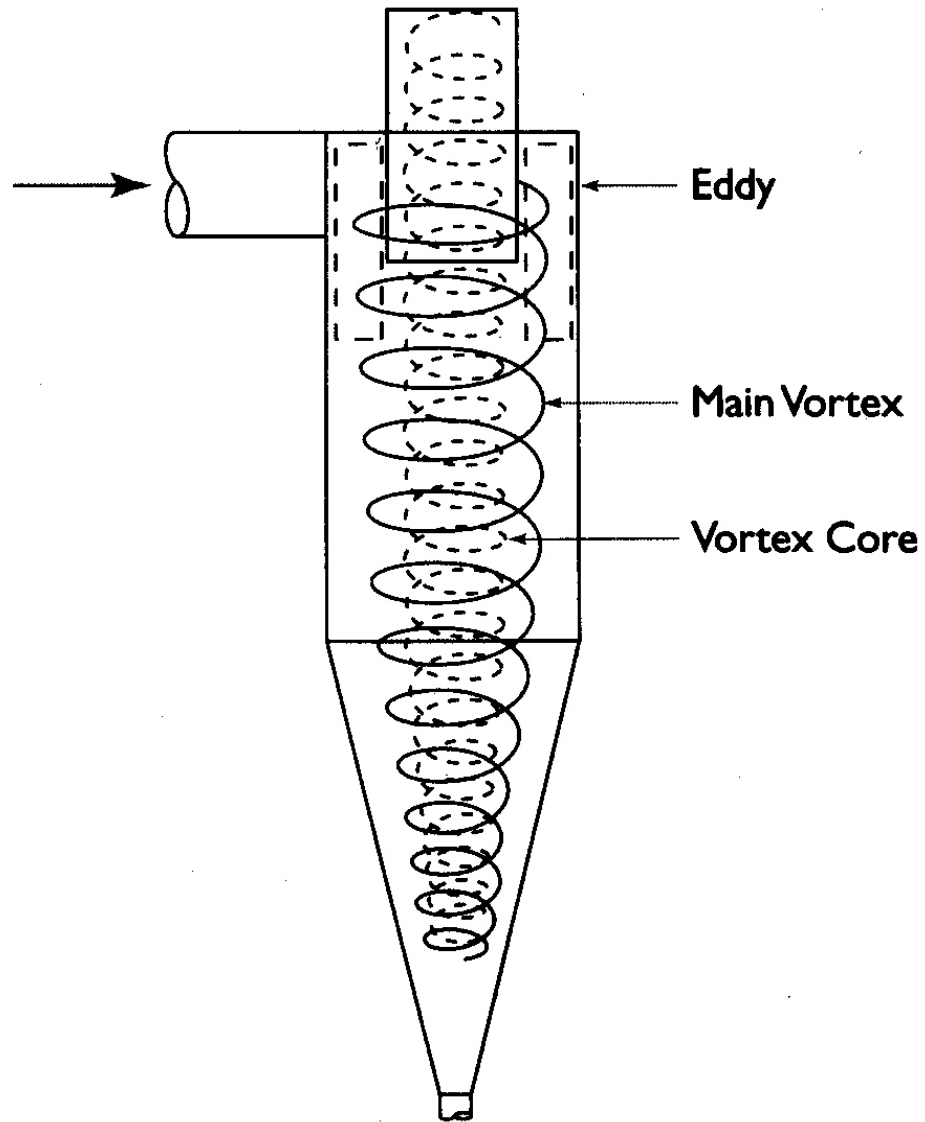

Adapted from Koutrakis and Sioutas (1996)

Figure 1.7. Schematic representation of a typical denuder used to separate gas-phase species from an aerosol.

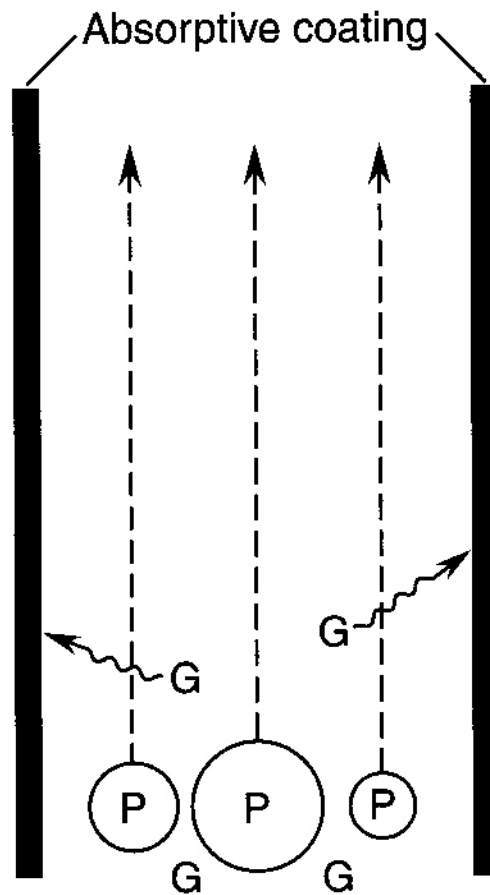

Adapted from Finlayson-Pitts and Pitts (1999)

distance along the denuder can be explained by the following equation:

$$\frac{C_x}{C_0} = 0.819e^{\left(-11.49 \frac{D_x}{Q}\right)} \quad (1.6)$$

where C_0 and C_x are the mass concentrations of the gas at the entrance to the denuder and at distance x , respectively. D_x is the diffusion coefficient of the gas in air and Q is the volumetric flow rate (Durham *et al.*, 1987). Typically the walls of the denuder are coated with a substance that is used to sorb the gas-phase species of interest. Denuders are available for the removal of gas-phase organic compounds, nitric acid, sulfur dioxide, nitrogen dioxide, ammonia and ozone (Krieger and Hites 1992; Koutrakis *et al.*, 1993; Eatough *et al.*, 1993).

Dryers/Heaters. Several methods have been used to remove particle bound water. The TEOM monitor, discussed in Chapter 2, heats the aerosol to temperatures above the deliquescent point to remove particle bound water. However, at these elevated temperatures, significant evaporative losses of SVM occur (Mignacca and Stubbs, 1999). Nafion dryers have been used to remove particle bound water at ambient temperatures to reduce the effects of evaporative losses of SVM (Eatough *et al.*, 2001; 1999; Long *et al.*, 2002; Obeidi and Eatough, 2002; Obeidi *et al.*, 2002; Pang *et al.*, 2002b).

1.10.2. Accuracy and Precision

The determination of the accuracy of a PM monitoring technique is non-attainable at the present time because no standard reference calibration of atmospheric PM exists. Ambient PM is a complex mixture of chemical components and is highly variable depending on location, source emissions, and atmospheric secondary processes. It is

therefore impractical to produce a calibration standard that accounts for both natural and anthropogenic components of PM, including SVM.

The inter-comparison of sampling techniques has become a widely used tool to determine the precision of identical monitors. Inter-comparison studies can also be used to determine the extent to which two different monitoring techniques agree. These types of studies have become useful in the elucidation of specific problems associated with monitoring and/or analytical techniques.

1.10.3. The PM_{2.5} Federal Reference Method

Because no calibration standard for ambient PM exists, the EPA designated the measurement of PM_{2.5} mass according to the FRM, which uses a single filter to sample ambient PM (Musick, 1999; Schaefer *et al.*, 1997), as the instrument used to determine attainment status. The FRM was also designated as the standard for comparison of other ambient PM monitoring techniques and used by monitoring networks to provide attainment/non-attainment information for compliance with NAAQS designated standards of PM_{2.5}. The configuration and operation of the PM_{2.5} FRM is discussed in Chapter 2. Several uncertainties endure relative to the relationship of particles measured on the FRM collection filter compared to the mass and composition of particles suspended in the atmosphere prior to collection. Single filter samplers, such as the PM_{2.5} FRM, can accurately measure stable species such as trace and crustal elements (Musick, 1999). However, these samplers cannot accurately determine semi-volatile fine particulate species such as ammonium nitrate and organic material (Eatough *et al.*, 2003; Hering and Cass, 1995).

1.10.4. The Measurement of Semi-Volatile Material

SVM can be a significant portion of urban aerosols (Eatough *et al.*, 2003).

However, it is difficult to measure and characterize atmospheric particles, particularly those classified as semi-volatile species. SVM, including water, ammonium nitrate, and semi-volatile organic species, can lead to both positive and negative sampling artifacts.

The problem associated with evaporative losses of SVM from collection media is illustrated in Figure 1.4 as negative artifacts.

In performing particulate mass and diameter measurements, it is desirable to remove particle-bound water to inhibit overestimation of particulate mass. However, the amount of water associated with urban particles is highly variable and dependent upon both the relative humidity and the composition of the aerosol. Furthermore, water absorption and desorption pathways can be complicated by hysteresis effects (Seinfeld and Pandis, 1998). As mentioned previously, both heaters and dryers have been used to remove particle bound water from ambient particles.

Ammonium nitrates in particles can be significant in urban atmospheres where SO₂ emissions are low and ammonia concentrations are high. It is well understood that significant volatilization losses of particulate nitrates can occur during sampling on single filter samplers. In regions with high ammonium nitrate concentrations such as southern California, the FRM will consistently underestimate PM_{2.5} mass concentrations due to volatilization losses of ammonium nitrate. A study conducted in Bakersfield, CA, by Pang *et al.*, (2002a) suggested that the amount of ammonium nitrate lost from filter-based samplers was a function of ambient temperature and %RH, with temperature being the biggest factor. They estimated the amount of nitrate lost from FRM samplers during

February - March 1998 to be approximately 30% (7.3 g/m^3). Hering and Cass (1999) also estimated the amount of ammonium nitrate lost from single filter collection at 28% based on two studies conducted in Southern California. They observed that the volatilization loss of nitrate was greater during the summer than during the fall in both studies.

SVOC's can also be a major fraction of urban $\text{PM}_{2.5}$ and also may be important due to implications in possible adverse health effects (Pope *et al.*, 2000, 2004). Volatilization losses of these low molecular weight organic compounds often occur from single-filter collection devices leading to potentially significant underestimation of $\text{PM}_{2.5}$ carbonaceous material. Pang *et al.*, (2002a) estimated that an average of 56% of fine particulate carbonaceous material was lost from the FRM collection filter in Bakersfield, CA during February - March 1998. Cui *et al.*, (1998) found that volatilization losses of organic material was greater during the day than at night for a summer study conducted in the Los Angeles Basin. They estimated that an average of 62% and 42% of the particulate organic material was lost due to volatilization of SVOM during the daytime and nighttime, respectively.

1.10.5. Fine Particulate Matter Monitoring Techniques

Several monitoring techniques have been developed to monitor both nonvolatile material (NVM) and SVM components of $\text{PM}_{2.5}$ and those used in the studies conducted for this dissertation are discussed in detail in Chapter 2. Although a comprehensive list of all types of analytical $\text{PM}_{2.5}$ sampling techniques is not feasible due to the continuous development of new methods, several text and review articles are available to provide

adequate information on the most predominantly used methods (Finlayson-Pitts and Pitts, 1999; Wilson and Spengler, 1996; McMurry, 2000; Chow, 1995; US EPA 2003). $PM_{2.5}$ monitoring techniques fall into two main categories: (1) integrated samplers that require the collection, transport, and in-lab analysis of filters to determine $PM_{2.5}$ mass and/or chemical components, and (2) semi-continuous monitoring techniques that perform continuous self-sustaining analysis of $PM_{2.5}$ mass and/or chemical components and can be readily applied in the field with little operator attention. Although several integrated samplers exist that can accurately determine both NVM and SVM (Eatough *et al.*, 2003), there are several drawbacks to these types of samplers. Integrated samplers are very labor and cost intensive. Collection of filter media and in-lab analysis are time consuming and expensive, resulting in data interpretation weeks and months from the time of collection. The potential for sample contamination is increased with collection, transport, and laboratory analysis. Furthermore, 1-h time resolved data is often not possible with integrated samplers, which inhibits the ability to temporally resolve short-term changes in pollution levels that often occur in urban environments.

To overcome the problems associated with integrated samplers, the development of semi-continuous methods has been attempted. Semi-continuous instruments have several advantages, including reliability, cost effectiveness, ease of sampling, and reduction in labor requirements. One of the main advantages of semi-continuous instruments is the ability to temporally resolve short-term episodes of $PM_{2.5}$ that occur in urban environments. One-h semi-continuous data has also been shown to increase the performance (i.e., reduce uncertainty) of source apportionment techniques to determine

sources, both primary and secondary, of urban PM (Grover *et al.*, in press; Grover *et al.*, submitted).

Significant work has been performed at Brigham Young University (BYU) to develop instruments to accurately determine all components of PM_{2.5} including both nonvolatile and semi-volatile species. These instruments are described in detail in Chapter 2 and include the particle concentrator-Brigham Young University organic sampling system (PC-BOSS) and the real-time total ambient mass sampler (RAMS).

PC-BOSS Validation and Comparisons. The PC-BOSS has been extensively tested and validated in several field studies consisting of a variety of atmospheric conditions and aerosol compositions, with a representative sample of these studies shown in Figure 1.8 (Ding *et al.*, 2002b; Pang *et al.*, 2002a; Pang *et al.*, 2002b; Eatough *et al.*, 1999a; Ding *et al.*, 2002b; Lewtas *et al.*, 2001; Modey *et al.*, 2001; Modey *et al.*, 2002; Modey and Eatough, 2002; Long *et al.*, 2002a-b; Grover *et al.*, 2005). The configuration and operation of the PC-BOSS is extensively described in Chapter 2.

In all of the sampling programs completed to date, the PC-BOSS has been shown to routinely and accurately measure all of the major constituents of urban aerosols, including concentrations of nitrate, semi-volatile ammonium nitrate, sulfate, nonvolatile organic material, and semi-volatile organic material by comparison with other denuder sampling systems for the various components measured. Measured mass concentrations are obtainable from Teflon filter mass data, and crustal material concentrations can be estimated by PIXE analysis. In the initial validation studies, the precision of collocated PC-BOSS samplers for particulate mass, carbonaceous material, sulfate, and nitrate was determined to be approximately 10%. The efficiency of the PC-BOSS denuder to

Figure 1.8. Fine particulate composition of aerosols in 7 U.S. cities determined by the PC-BOSS.

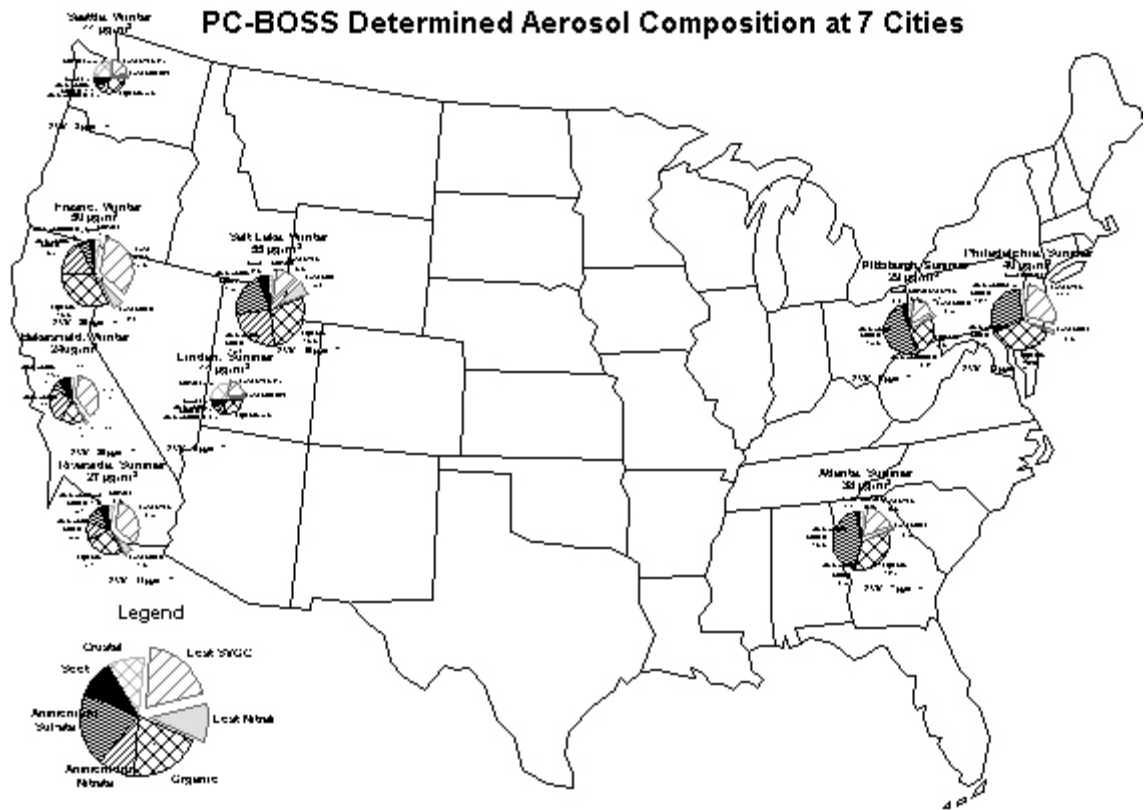

Adapted from Wilson *et al.*, (In Press)

remove interfering gases including gas-phase organic material, SO₂, and nitric acid is greater than 99%. The PC-BOSS denuder also efficiently removes gas phase ozone, NO₂ and ammonia (Ding *et al.*, 2002a; Pang *et al.*, 2001; Obeidi and Eatough, 2002).

One of the unique features of the PC-BOSS is the ability to measure the amount of SVM lost from the Teflon and quartz collection filters. Concentrations of semi-volatile nitrate are determined after the diffusion denuder by the amount of nitrate lost from the Teflon filter and collected on the nylon filter. Semi-volatile carbonaceous material is determined by the amount of organic material lost from the quartz filter and collected on the CIG filter. For the studies indicated, the amount of SVM lost from the collection filters ranged from less than 10% to 50% of the measured mass. An important observation in all of these studies is that for sample collection times of 3-h or longer, with correction for the positive gas-phase artifact, the loss of particulate SVM is the same for collection of particles with or without a preceding denuder. At most of the sampling locations, the majority of lost SVM was semi-volatile organic material, but semi-volatile ammonium nitrate constituted a major fraction of the SVM lost at the southern California sampling locations (Figure 1.8). It is reasonable to assume that a similar amount of SVM is lost from the single Teflon collection filter of the FRM.

Comparisons between a PC-BOSS constructed mass and FRM measured mass were made for studies conducted along the Wasatch Front and those conducted in Bakersfield, CA where FRM data were available. PC-BOSS constructed mass can be obtained by the summation of all the aerosol chemical constituents measured by the PC-BOSS, including nitrate, semi-volatile nitrate, sulfate, nonvolatile organic material, and semi-volatile organic material. Crustal material was estimated from Al and Si data using

crustal averages for these elements obtained by PIXE analysis. In areas with excess ammonia in the atmosphere, nitrate and sulfate were considered to be present as ammonium nitrate and ammonium sulfate, respectively. It was also assumed that fine particulate organic material was 61% carbon, typical of an aged urban aerosol (Turpin and Lim, 2001). However, during studies conducted along the Wasatch Front, the region was periodically impacted by fresh wood smoke from forest fires and the fine particulate organic material was assumed to be 71% carbon, which is more typical of a fresh aerosol (Malm *et al.*, 1994; Turpin and Lim, 2001). Linear regression statistics for these studies are given in Table 1.5.

The Wasatch Front studies were conducted during two winter sampling conditions and one summer sampling period at two locations (Bountiful and Hawthorne) in the Salt Lake City urban area and have been previously described (Long *et al.*, 2002). During winter sampling conditions PC-BOSS and FRM results were comparable, as shown in Table 1.5 and Figure 1.9. The agreement between the PC-BOSS and the FRM during the winter periods is most likely the result of cold and humid weather conditions, which can have a stabilizing effect on SVM. Subsequently, SVM is not lost from the single Teflon collection filter of the FRM under these conditions. For the winter sampling period of 2000-2001, the FRM measured mass was greater than the constructed mass of the PC-BOSS for several samples. During these sampling periods in Salt Lake City the average relative humidity was close to 100% and the temperatures were consistently below freezing. Particles associated with substantial amounts of water and the stabilization of semi-volatile species occurs under these low temperature and high %RH conditions (Long *et al.*, 2003). The higher mass observed with the FRM sample is

Table 1.5. Linear Regression Statistics for the Studies Conducted with Instruments Developed at Brigham Young University for the Measurement of Nonvolatile and Semi-Volatile Particulate Matter.

X vs Y	n	R ²	Slope ^a	Intercept g/m ³	X Average g/m ³	X-Y Bias g/m ³	g/m ³	%
PC-BOSS vs FRM								
Wasatch Front Winter (1999- 2000)	51	0.94	0.94 ± 0.02	0	18.2	2.0	1.8	10.7
		0.92	1.07 ± 0.04	-3.24				
Wasatch Front Summer (2000)	41	0.76	0.47 ± 0.02	0	19.3	10.2	NA ^b	
		0.76	0.48 ± 0.04	-0.09				
Wasatch Front Winter (2000- 2001)	38	0.83	1.23 ± 0.05	0	24.7	-5.1	6.0	22.1
		0.83	1.29 ± 0.10	-2.18				
Bakersfield, CA	30	0.86	0.76 ± 0.03	0	20.9	5.0	NA ^b	
		0.86	0.87 ± 0.07	-2.4				
RAMS vs PC-BOSS								
Wasatch Front Winter (1999- 2000)	47	0.90	1.01 ± 0.03	0	17.1	-0.6	2.7	15.2
		0.90	0.95 ± 0.05	1.40				
Wasatch Front Summer (2000)	41	0.82	1.03 ± 0.03	0	14.0	-1.2	2.2	14.8
		0.86	0.88 ± 0.06	2.95				
Wasatch Front Winter (2000- 2001)	28	0.90	0.99 ± 0.03	0	29.0	0.1	3.4	11.9
		0.90	0.96 ± 0.06	1.10				
Wasatch Front Complete Study	116	0.90	1.00 ± 0.02	0	18.7	-0.7	2.8	14.4
		0.91	0.94 ± 0.03	1.86				
RAMS vs TEOM								
Wasatch Front Complete Study	446	0.44	0.55 ± 0.00	0	19.6	6.6	7.3	45.1
	1	0.53	0.42 ± 0.01	4.47				

^aSlopes are given for (1) zero intercept and (2) calculated intercept

^bNA, could not be calculated because the sampler bias was greater than .

Adapted from Wilson *et al.*, (In press)

Figure 1.9. PC-BOSS constructed mass vs FRM equilibrated mass for studies conducted at the Salt Lake City EMPACT site for both summer and winter sampling conditions.

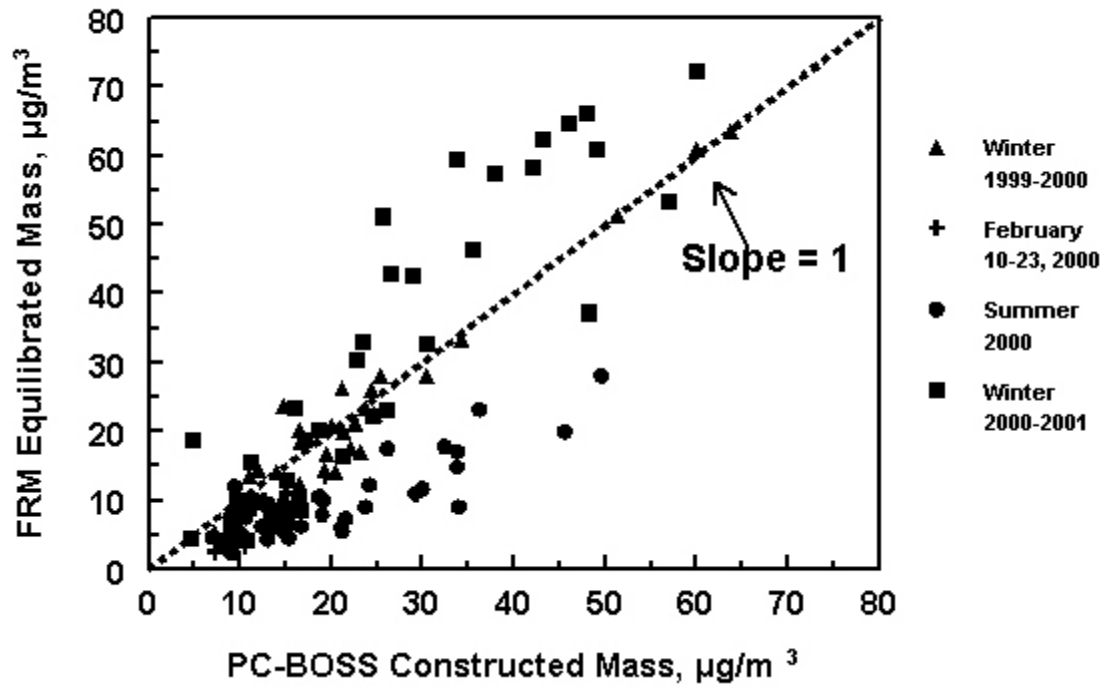

Adapted from Long *et al.*, (2003)

most likely due to the measurement of water that is not released during the 24-h equilibration period used for the Teflon filters of the FRM. During the summer sampling period at Hawthorne, where weather conditions were dominated by hot and dry conditions, the PC-BOSS mass measurements were much higher than those obtained by the FRM, shown in Figure 1.9 and Table 1.5. The majority of SVM was not retained by the FRM single Teflon filter under summer sampling conditions when more SVM was present in the aerosol.

The Bakersfield, CA study was conducted during February and March of 1998 (Pang *et al.*, 2002b) and linear regression statistics between the PC-BOSS constructed mass and the FRM during this study are shown in Table 1.5. Although the Bakersfield study was conducted during the winter months, the meteorological conditions observed during the study were not as cold and humid as those observed along the Wasatch Front during the winter. Subsequently, the majority of the SVM present in the aerosol was not measured by the FRM sampler during this sampling period.

One of the major advantages of the PC-BOSS is the ability to speciate the major components of $PM_{2.5}$. When $PM_{2.5}$ concentrations are sufficient, 1-3 h temporal resolution is obtainable using the PC-BOSS. Three-h averaged concentrations of all of the major components of fine particulate material are shown in Figure 1.10 for a five day period during the studies conducted along the Wasatch Front (Eatough *et al.*, 2004).

The RAMS Validation and Comparisons. To overcome the problems associated with integrated samplers, as mention previously, the development of a semi-continuous monitor for $PM_{2.5}$ mass was attempted. The RAMS has been extensively validated and field tested. Comparisons were made between fine particulate mass,

Figure 1.10. Three-h fine particulate species concentrations determined by the PC-BOSS for a 5 day period along the Wasatch Front.

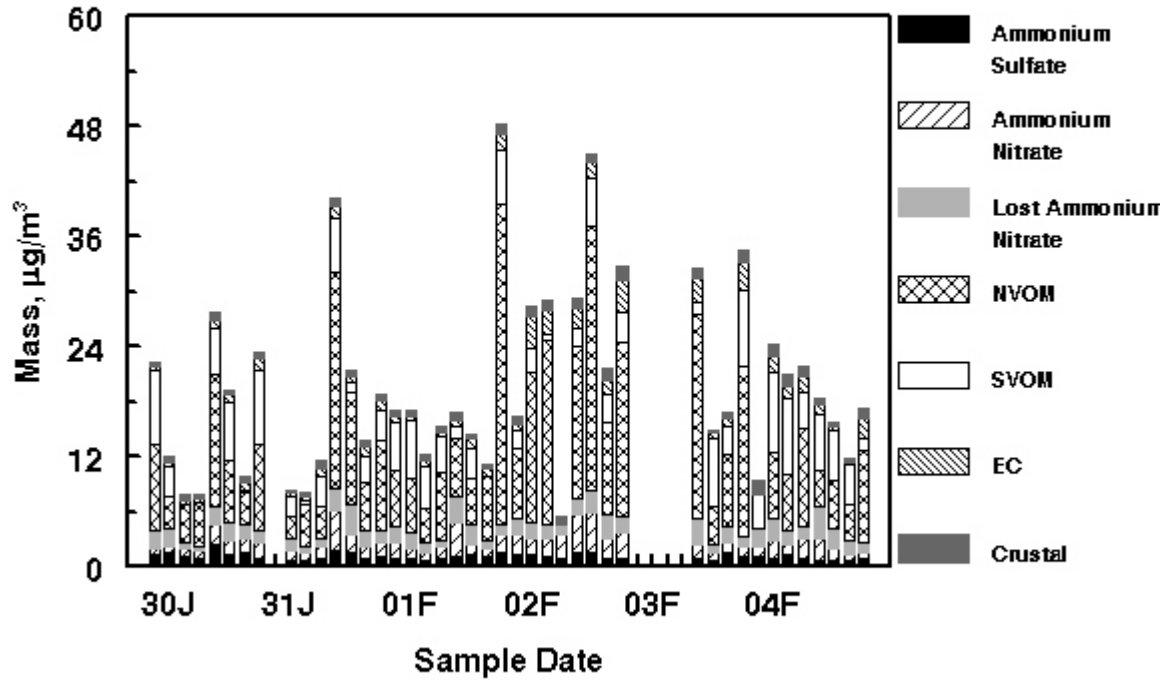

Adapted from Eatough *et al.*, (2004).

measured by the RAMS, and constructed mass, measured by the PC-BOSS, in studies with various types of urban aerosols and meteorological conditions. These studies include sampling campaigns conducted in Provo, UT (Eatough, *et al.*, 2001; Obeidi and Eatough, 2002), in Riverside and Bakersfield, CA (Obeidi *et al.*, 2002), Philadelphia, PA and Atlanta, GA (Pang *et al.*, 2002b), during a 2 year EPA EMPACT/STAR sampling program in the urban Wasatch Front in Utah (Long *et al.*, 2002) and in Rubidoux, CA (Grover *et al.*, 2005).

In the initial studies conducted in Riverside, CA (Obeidi *et al.*, 2002), RAMS data were compared with 1-h PC-BOSS integrated samples. The ability of the RAMS to measure fine particulate matter, including semi-volatile ammonium nitrate and semi-volatile organic material, is illustrated in Figure 1.11 by the agreement between the RAMS and 1-h PC-BOSS data. High concentrations of SVM were observed during the noon to evening time period displayed in Figure 1.11 with a major fraction of the aerosol being semi-volatile species as indicated by the PC-BOSS data. During the entire period displayed, TEOM monitor measurements were less than RAMS and PC-BOSS measurements. Because of the heated inlet of the TEOM monitor, essentially all SVM is lost from the collection filter and subsequently not measured. The RAMS however, retains all of the SVM by collection on the “sandwich” filter. The retention of SVM by the “sandwich” filter of the RAMS that is not retained on the TX40 collection filter of the TEOM is equivalent to the difference between the two measurement systems. Also, the difference between the RAMS data and the TEOM monitor data for each 1-h period when PC-BOSS samples were collected is equivalent to the amount of SVM measured by the PC-BOSS (Figure 1.11). Also displayed in Figure 1.11 is the concentration of $PM_{2.5}$

Figure 1.11. Comparison of fine particulate mass measured by the RAMS, TEOM, PC-BOSS and FRM in Riverside, CA. PC-BOSS concentrations are split into nonvolatile and semi-volatile fractions. Semi-volatile $PM_{2.5}$ is measured by the RAMS and PC-BOSS but not by the conventional TEOM nor the FRM sampler.

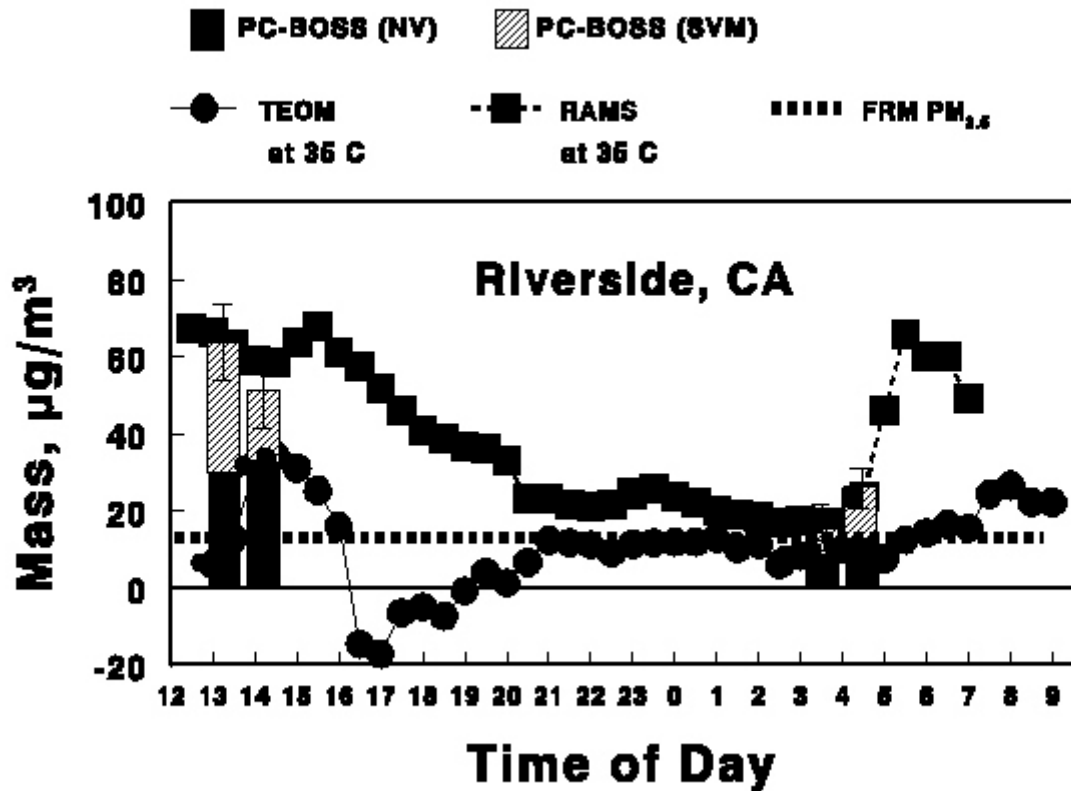

Adapted from Obeidi *et al.*, (2002)

measured by the FRM over the same time period. The average TEOM concentration over the time period was slightly higher than that obtained by the FRM being 12.3 g/m³ and 11.5 g/m³, respectively. However, approximately 38% of the total fine particulate mass was not measured by the TEOM or FRM due to the loss of SVM from the respective collection filters. These data illustrate the ability of the PC-BOSS and RAMS to measure fine particulate semi-volatile species that are not collected by the FRM nor the heated TEOM monitor.

Studies Conducted Along the Wasatch Front. The ability of the RAMS monitor to measure total PM_{2.5} concentrations, including SVM, is robustly illustrated by the data collected under the umbrella of the EPA STAR/EMPACT programs along the Wasatch Front in Utah. The Wasatch Front studies were conducted during two winter sampling periods (1999-2000 and 2000-2001) and one summer sampling period (2000).

Constructed mass, obtained for each 24-h PC-BOSS sample, was calculated as the sum of ammonium sulfate obtained from sulfate on the Teflon filters, ammonium nitrate from the nitrate on the Teflon filters, the volatile ammonium nitrate from the nitrate on the nylon filters, the EC collected on the quartz filter, the total organic carbonaceous material which is the sum of the organic material on the quartz filter and the semi-volatile organic material lost from the particles during collection on the quartz filter but collected on the CIG filters, and the sum of crustal material estimated from Al and Si concentrations. Generally, crustal material mass determined by the PC-BOSS is approximately 5% of the nonvolatile mass measured by the TEOM monitor. PC-BOSS constructed mass does not include any particle bound water.

Because the PC-BOSS has been shown to measure both nonvolatile and semi-volatile components of $PM_{2.5}$ (Eatough *et al.*, 1999; Lewtas *et al.*, 2001), the PC-BOSS during these studies was taken to accurately represent concentrations of total fine particulate matter in the atmosphere. The continuous measurements of total concentrations of $PM_{2.5}$, including both nonvolatile and semi-volatile species, were averaged (24-h) for comparison with the PC-BOSS collected samples for the three seasonal periods. These data are illustrated in Figure 1.12. Linear regression analysis of RAMS measured and PC-BOSS constructed $PM_{2.5}$ mass resulted in a zero intercept slope of 1.01 ± 0.03 ($n = 47$) with an $R^2 = 0.90$ for the winter 1999-2000 (Table 1.5). For the summer 2000 period, a zero intercept slope of 1.03 ± 0.03 and an $R^2 = 0.82$ ($n = 41$) was obtained. Linear regression analysis of the RAMS measured vs. the PC-BOSS constructed mass for the winter 2000-2001 sampling period resulted in a zero intercept slope of 0.99 ± 0.03 with $R^2 = 0.90$ ($n = 28$) (Table 1.5). For the combined data of all three seasonal periods, a zero intercept slope of 1.00 ± 0.02 with an $R^2 = 0.90$ (Table 1.5) was obtained.

These studies, and others indicate that the RAMS monitor can continuously and accurately measure total $PM_{2.5}$ mass concentrations, including both nonvolatile and semi-volatile species. However, particle bound water is not measured by the RAMS due to the use of Nafion dryers to remove water from the sampling stream. For the studies completed to date the precision of the RAMS is approximately $\pm 10\%$ or $\pm 2 \text{ g/m}^3$.

During the studies conducted to date, the RAMS monitor data have been consistently greater than or equal to the TEOM monitor data. This is due to the ability of

Figure 1.12. PC-BOSS constructed mass vs RAMS measured mass for studies conducted along the Wasatch Front from 1999-2001.

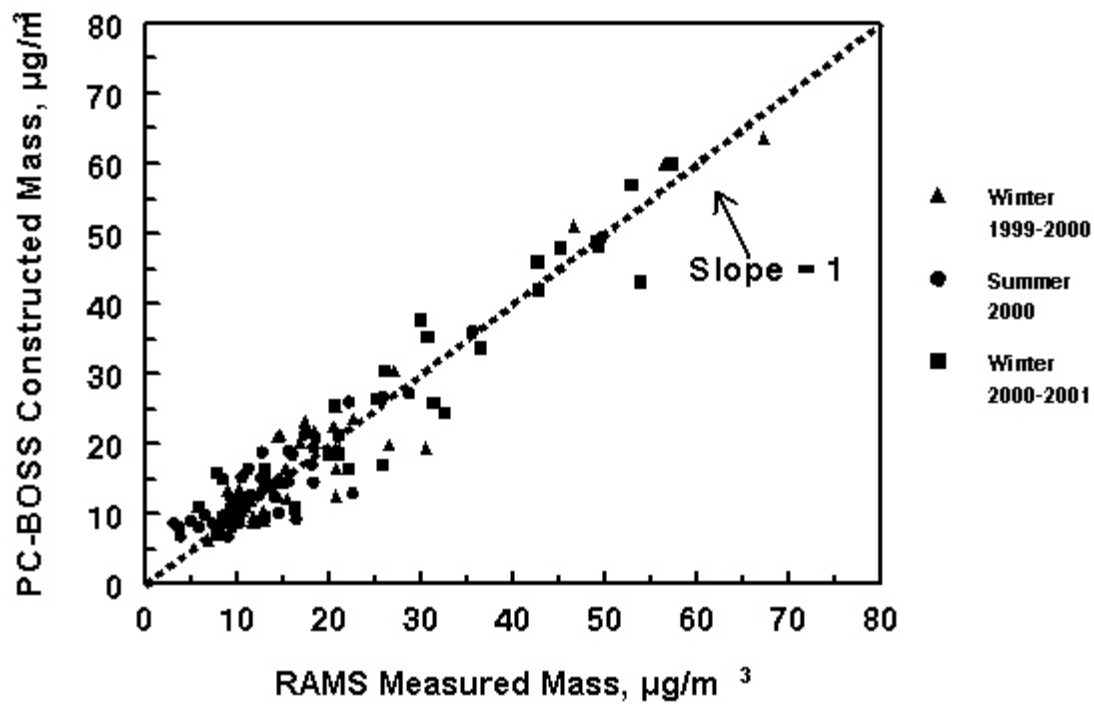

Adapted from Long *et al.*, (2002).

the RAMS to measure SVM, which is lost from the heated inlet and filter of the TEOM monitor. This is illustrated for both summer and winter sampling conditions in Figure 1.13, for the studies conducted along the Wasatch Front. For the winter sampling period at the Bountiful sampling site, the RAMS and TEOM PM_{2.5} mass averages were 46 and 29 g/m³, respectively. At Hawthorne during the winter, the PM_{2.5} mass averages measured by the RAMS and TEOM monitors were 55 and 29 g/m³, respectively. For the summer sampling period at Hawthorne, the RAMS and TEOM averages were 19 and 14 g/m³, respectively, the first week, and 39 and 23 g/m³, respectively, for the second week. The greatest difference between the RAMS and TEOM monitor data during the Wasatch Front sampling periods was observed during the summer when the area was impacted by wood smoke emissions from forest fires. The high concentrations of pollutants and the high levels of photochemical activity observed during the summer period resulted in significant amounts of SVM present in the atmosphere at the Hawthorne sampling site. The linear regression analysis statistics for comparisons between the RAMS and the TEOM monitor data for the complete study along the Wasatch Front are given in Table 1.5.

1.11. Goals of the Research

The accurate determination of all components of ambient PM_{2.5} is extremely important because of observed adverse effects on health, visibility, and global radiative balance. Because a significant portion of PM_{2.5} has been shown to be semi-volatile, and SVM may be important in cardiovascular human health effects (Pope *et al.*, 2000; Pope

Figure 1.13. RAMS vs TEOM measured mass concentrations for studies conducted along the Wastach Front during the winter in Bountiful, UT (A) and during a winter (B) and a summer (C) in Hawthorne, UT.

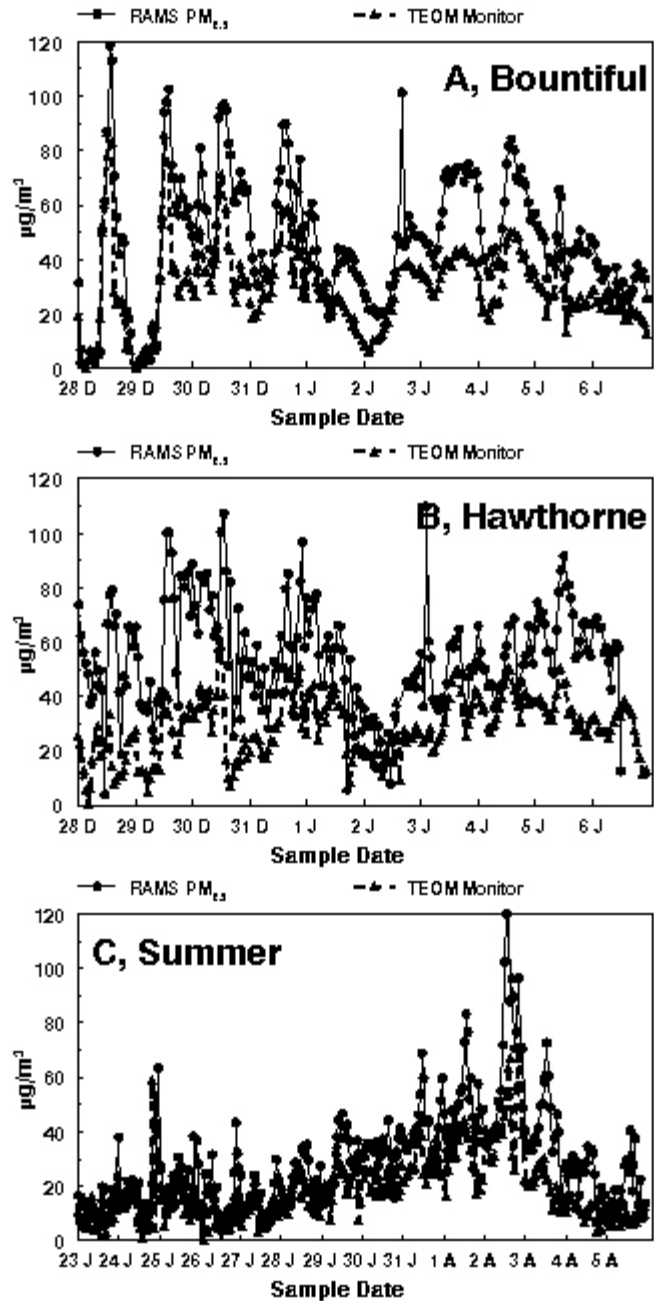

et al. 2004), the development of instruments to accurately measure the semi-volatile fraction of $PM_{2.5}$ is essential.

It was the postulate of the research described in this dissertation that the development and validation of appropriate monitoring techniques would allow for the accurate semi-continuous characterization of urban PM including the semi-volatile fraction. The measurement of this time-relevant exposure of a population to total $PM_{2.5}$ mass and components, including particulate semi-volatile species, would assist in the identification of $PM_{2.5}$ etiological agents which result in mortality and morbidity effects associated with exposure to fine particles. This would allow for the development of appropriate attainment strategies, the collection of better exposure data, and an improvement in risk assessment studies and analyses. Furthermore, this was the first attempt to characterize both nonvolatile and semi-volatile fractions of an urban aerosol in a continuous (1-h average) manner using all semi-continuous instruments.

While the RAMS has been shown to measure total fine particulate mass, including the semi-volatile ammonium nitrate and semi-volatile organic components, the sampler is not suitable for routine use in field sampling because it requires regular observation and maintenance. A newly developed R&P FDMS monitor was evaluated for the routine field measurement of total $PM_{2.5}$. Also, a semi-continuous monitor (Dionex GP-IC) for soluble inorganic species was field tested for the first time. The development of a semi-continuous carbon monitor, for the simultaneous measurement of nonvolatile and semi-volatile carbonaceous material, was attempted. Source apportionment was conducted on ambient data sets using EPA UNMIX and positive matrix factorization to determine sources, both primary and secondary, of urban $PM_{2.5}$.

1.12. References

- Aumont, B., Madronich, S., Bey, I., Tyndall, G.S. (2000) Contribution of secondary VOC to the composition of aqueous atmospheric particles: A modeling approach. *J. Atmos. Chem.* 35: 59-75.
- Bell, M.L., Davis, D.L. (2001). Reassessment of the lethal London Fog of 1952: Novel indicators of acute and chronic consequences of acute exposure to air pollution. *Environ. Health Perspect.* 109: S3.
- Chan, T., Lippman, M., (1997) Particle collection efficiencies of air sampling cyclones: an empirical theory. *Environ. Sci. Technol.* 11: 377.
- Chow, J. C. (1995). Measurement Methods to Determine Compliance with Ambient Air Quality Standards for Suspended Particles. *J. Air & Waste Manage. Assoc.* 45: 320-382.
- Cui, W., Eatough, D.E., Eatough, N.L. (1998) Fine particulate organic material in the Los Angeles Basin - I: assesment of the high-volume Brigham Young University organic sampling system, BIG BOSS. *J. Air Waste Manage. Assoc.* 48: 1024-1037.
- Davis, D. (2002). When Smoke Ran Like Water. Tales of Environmental Deception and the Battle Against Pollution. Persues Books, New York. pp. 5-54.
- Ding, Y., Pang, Y., Eatough, D.J., (2001). High volume diffusion denuder sampler for the routine monitoring of fine particulate matter: I. Design and optimization of the PC-BOSS. *Journal of Aerosol Sci. Technol.* 36: 369-382.
- Ding, Y., Pang, Y., Eatough, D.J., Eatough, N.L., and Tanner, R.L. (2002a). High-Volume Diffusion Denuder Samplers for the Routine Monitoring of Fine Particulate Matter: I. Design and Optimization of the PC-BOSS. *Aerosol Sci. Technol.* 36: 369-382.
- Ding, Y., Pang, Y., Eatough, D.J., Eatough, N.L., and Tanner, R.L. (2002b). High-Volume Diffusion Denuder Samplers for the Routine Monitoring of Fine Particulate Matter: II. Field Evaluation of the PC-BOSS. *Aerosol Sci. Technol.* 36: 383-396.
- Dockery D.W., Pope C.A III, Xu X., Spengler, J.D., Ware, J.H., Louis, T.A., Spiro, A.III (1993). An association between air pollution and mortality in six U.S. cities. *New England J. Med.* 329:1753-1759.
- Dockery, D.W., Schwartz, J., Spengler, J.D. (1992). Air pollution and daily mortality: Associations with particulates and acid aerosols. *Environ. Research.* 59:362-373.
- Dockery, D.W., Pope, C.A. III (1994). Acute respiratory effects of particulate air pollution. *Ann. Rev. Public Heath.* 15:107-132.

- Durham, J.L., Spiller, L.L., Ellestad, T.G. (1987) Nitric-acid-nitrate aerosol measurements by a diffusion denuder: A performance evaluation. *Atmos. Environ.* 21: 589-598.
- Eatough, D.J., Wadsworth, A., Eatough, D.A., Crawford, J.W., Hansen, L.D., and Lewis, E.A., (1993) A multiple-system, multi channel diffusion denuder sampler for the determination of fine particulate organic material in the atmosphere.
- Eatough, D.J., Obeidi, F., Pang, Y., Ding, Y., Eatough, N.L., Wislon, W.E. (1999). Integrated and real-time diffusion denuder sampler for PM_{2.5}. *Atmos. Environ.* 33: 2835-2844.
- Eatough, D.J., Eatough, N.L., Obeidi, F., Pang, Y., Modey, W., and Long, R. (2001) Continuous determination of PM_{2.5} mass, Including Semi-Volatile Species. *Aerosol Sci. Technol.* 34, 1-8.
- Eatough, D.J., Long, R.W., Modey, W.K., Eatough, N.L. (2003). Semi-Volatile Secondary Organic Aerosol in Urban Atmospheres: Meeting a Measurement Challenge. *Atmos. Environ.* 37: 1277-1292.
- Eatough, D.J., Eatough, N.L., Malm, W.C., Long, R.W., Wilson, W.E. (2004). One- and three- hour PM_{2.5} characterization, speciation and visibility apportionment using continuous and integrated samplers. *Proceedings of the Air and Waste Management Association Regional and Global Perspectives on Haze Specialty Conference*. Asheville, NC. October 25-29, 2004.
- Eldering, A., Cass, G.R., Moon, K.C. (1994). An air monitoring network using continuous particle size distribution monitors: connecting pollutant properties to visibility via Mie scattering calculations. *Atmos. Environ.* 28: 2733-2749.
- Faust, B.C. (1994). Photochemistry of clouds, fogs, and aerosols. *Environ. Sci. Technol.* 28: 217A-222A.
- Federal Register. (1999). Regional haze regulations; final rule. F.R. (July 1) 64:35,713-35,774.
- Finlayson-Pitts B.J, J. N. Pitts, (1999). *Chemistry of the Upper and Lower Atmosphere* Academic Press, San Diego, CA.
- Fuller, K.A., Malm, W.C., Kreidenweis, S.M. (1999). Effects of mixing on extinction by carbonaceous particles. *J. Geophys. Res.* 104: 15941-15945.
- Godleski, J.J., Sioutas, C., Katler, M., Koutrakis, P. (1996). Death from inhalation of concentrated air particles in animal models of pulmonary disease. *Am. J. Respir. Crit. Care Med.* 153: A15.

- Godleski, J.J., Sioutas, C., Verrier, R.L., (1997). Inhalation exposure of canines to concentrated ambient air particles. *Am. J. Respir. Crit. Care Med.* 155: A246.
- Godleski, J.J., Verrier, R.L., Koutrakis, P., and Catalano, P. (2000). Mechanisms of morbidity and mortality from exposure to ambient air particles. Health Effects Institute, research report no. 91.
- Graedel, J.K., Goldberg, K.I. (1983). Kinetic studies of raindrop chemistry: 1. Inorganic and organic processes. *J. Geophys. Res. C: Oceans Atmos.* 88: 10865-10882.
- Grover, B.D., Eatough, D.J., Source apportionment of 1-h semi-continuous data using positive matrix factorization with total mass (nonvolatile plus semi-volatile) measured by the R&P FDMS monitor. *Aerosol Sci. Technol.* Submitted.
- Grover, B. D, Carter, C. B. Kleinman, M. A., Richards, J. S., Eatough, N. L. and Eatough, D. J. Monitoring and Source Apportionment of Fine Particulate Matter at Lindon, Utah. *Aerosol Sci. Technol.* In press.
- Grover, B.D., Kleinman, M., Eatough, N.L., Eatough, D.J., Hopke, P.K., Long, R.W., Wilson, W.E. Meyer, M.B., Ambs, J.L., (2005). Measurement of total PM_{2.5} mass (nonvolatile plus semi-volatile) with the FDMS TEOM monitor. *J. Geophys. Res.* Vol. 110: D07S03.
- Haywood, J.M., Shine, K.P. (1995). The effect of anthropogenic sulfate and soot aerosol on the clear sky planetary radiation budget. *Geophys. Res. Lett.* 22: 603-606.
- Hefflin, B.J., Jalaludin, B., McClure, E., Cobb, N., Johnson, C.A., Jecha, L., Etzel, R.A. (1994). Surveillance for dust storms and respiratory disease in Washington State, 1991. *Archives Environ. Health.* 49(3): 170-174.
- Hering, S., Cass, G., (1999). The magnitude of bias in the measurement of PM_{2.5} arising from volatilization of particulate nitrate from Teflon filters. *J. Air Waste Manage. Assoc.* 49: 725-733.
- Husar, R.B., Whitby, K.T., Lui, B.Y.H. (1972). Physical mechanisms governing the dynamics of Los Angeles smog aerosol. *J. Colloid Interface Sci.* 39:211-224.
- Intergovernmental Panel on Climate Change (ICPP). (2001) Climate change 2001: the scientific basis. Contribution of working group I to the third assessment report of the Intergovernmental Panel on Climate Change. Cambridge, United Kingdom: Cambridge University Press.
- Kennedy, H.L. (1997). Beta blockade, ventricular arrhythmia, and sudden cardiac death. *Am J Cardiol* 80(9B): 29J-34J.

Koutrakis, P., Sioutas, C., Ferguson, S.T., Wolfson, J.M., Mulik, J.D., and Burton, R.M., (1993). Development and evaluation of a glass honeycomb denuder/filter pack system to collect atmospheric gases and particles. *Environ. Sci. Technol.* 27: 2497-2501.

Koutrakis, P., Sioutas, C. (1996). Physico-chemical properties and measurement of ambient particles. *Particles Our Outdoor Air: Concentrations and Health Effects*, Ch. 2, 15-40.

Krieger, M.S., Hites, R.A., (1992). Diffusion denuder for the collection of semi-volatile organic compounds. *Environ. Sci. Technol.* 26: 1551-1555.

Lewtas, J., Booth, D., Pang, Y., Reimer, S., Eatough, D.J., and Gundel, L. (2001). Comparison of sampling methods for semi-volatile organic carbon (SVOC) associated with PM_{2.5}. *Aerosol Sci. Technol.* 34: 9-22.

Long, R.W., Smith, R., Smith, S., Eatough, N.L., Mangelson and Eatough, D.J. (2002). Sources of Fine Particulate Material along the Wasatch Front, *Energy and Fuels*. 16: 282-293.

Long, R. W., Eatough, N. L., Mangelson, N. F., Thompson, W., Fiet, K., Smith, S., Smith, R., and Eatough, D. J., (2003). The Measurement of PM_{2.5}, Including Semi-Volatile Components, in the EMPACT Program: Results from the Salt Lake City Study and Implications for Public Awareness, Health Effects, and Control Strategies, *Atmos. Environ.* 37: 4407-4417.

Long, R. W., and McClenny, W. A., Laboratory and Field Evaluation of Instrumentation for the Semi-Continuous Determination of Particulate Nitrate (and other Water Soluble Components). Submitted to *J. Air & Waste Manage. Assoc.*

Malm, W.C., Gebhart, K.A., Molenaar, J., Cahill, T.A., Eldred, R.A., Huffman, D., (1994). Examining the relationship between atmospheric aerosols and light extinction at Mount Rainier and North Cascades national parks. *Atmospheric Environ.* 28: 247-360.

Malm, W.C. (2000). Spatial and seasonal patterns and temporal variability of haze and its constituents in the United States. Report III. Fort Collins, CO: Cooperative institute for research in the Atmosphere, Colorado State University. Available: <http://vista.cira.colostate.edu/improve/Publications/Reports/2000/2000.htm>

Malm, W.C., Day, D.E., Kreidenwies, S.M. (2000). Light scattering characteristics of aerosols as a function of relative humidity: part I-a comparison of measured scattering and aerosol concentrations using the statistical models. *J. Air Waste Manage. Assoc.* 50: 701-709.

- Mecherikunnel, A.T., Lee, R.B., Kyle, H.L., Majors, E.R. (1988). Intercomparisons of solar total irradiance data from recent spacecraft measurements. *J. Geophys. Res.* 93: 9503-9509.
- McMurry, P.H. (2000). A review of atmospheric aerosol measurements. *Atmos. Environ.* 34: 1959-1999.
- Modey, W. K., Pang, Y., Eatough, N. L., and Eatough, D. J., (2001). Fine Particulate (PM_{2.5}) Composition in Atlanta, USA: Assessment of the Particle Concentrator Brigham Young University Organic Sampling System, PC-BOSS, During the EPA Supersite Study, *Atmos. Environ.* 35: 6493-6502.
- Modey, W. K., Eatough, D. J. (2002). Trends in Composition at the Department of Energy OST NETL PM_{2.5} Characterization Site in Pittsburgh, Pennsylvania, USA. *Adv. Environ. Res.*, in press.
- Musick, D. (1999). A Summary of the Ambient Air Program for PM_{2.5} *Environ. Manager.* 17-20.
- Nature Resource Defense Council, NDRC, (1996). Breath Taking; Premature mortality due to particulate air pollution in 239 American cities. Washington, DC.
- Obeidi, F., Eatough, D.J. (2002). Continuous Measurement of semivolatile fine particulate mass in Provo, UT. *Aerosol Sci. Technol.* 36: 191-203.
- Pang, Y., Eatough, N.L., Wilson, J., Eatough, D.E., (2002a). Effect of semivolatile material on PM_{2.5} measurement by the PM_{2.5} federal reference method sampler at Bakersfield, California. *Aerosol Sci. Technol.* 36: 289-299.
- Pang, Y., Eatough, N.L., Modey, W.K., Eatough, D.E., (2002b). Evaluation of the RAMS continuous monitor for determination of PM_{2.5} mass including semi-volatile material in Philadelphia, PA. *J. Air Waste Manage. Assoc.* 52:563-572.
- Pandis, S.N., Harley, R.A., Cass, G.R., Seinfeld, J.H. (1992). Secondary organic aerosol formation and transport. *Atmos. Environ. Part A.* 26: 2269-2282.
- Peters, A., Wichmann, H.E., Tuch, T., Heinrich, J., Heyder, J., (1997). Respiratory effects are associated with the number of ultrafine particles. *Am J Respir Crit Care Med.* 155:1376-1383.
- Pilinis, C., Pandis, S.N., Seinfeld, J.H. (1995). Sensitivity of direct climate forcing by atmospheric aerosols to aerosol size and composition. *J. Geophys. Res. [Atmos]* 100: 18739-18745.

- Pope, C.A. III, (1989). Respiratory disease associated with community air pollution and steel mill, Utah Valley. *Amer. J. Public Health.* 79:623-628.
- Pope, C.A. III, Dockery, D.W., Spengler, J.D., Raizenne, M.E. (1991). Respiratory health and PM₁₀ pollution: a daily time series analysis. *Am Rev Respir Dis.* 144: 668-674.
- Pope, C.A. III, Dockery, D.W., (1992). Acute health effects of PM₁₀ pollution on symptomatic and asymptomatic children. *Am Rev Respir Dis.* 145:1123-1128.
- Pope, C.A. III, Dockery, D.W., Raizenne, J. (1995a). Health effects of particulate air pollution: Time for reassessment?. *Environ. Health Perspect.*10: 472-480.
- Pope, C.A. III, Thun, M.J., Namboodiri, M.M., Dockery, D.W., Evans, J.S., Speizer, F.E. Heath C.W., (1995b). Particulate air pollution as a predictor of mortality in a prospective study of U.S. adults. *Amer. J Resp. Cirt Care Med.* 151: 669-674.
- Pope, C.A. III, Dockery, D.W., Kanner R.E., Villefas, G.M., Schwarz, J. (1999). Oxygen saturated, pulse rate, and particulate air pollution: a daily time-series panel study. *Am. J. Respir. Crit Care Med.* 159: 365-372.
- Pope, C.A. III, (2000). Epidemiology of fine particulate air pollution and human health; Biological mechanisms and who's at risk?. *Environ. Health Perspect.*, 108(Sup 4): 713-723.
- Pope, C. A. III, Hansen, M. L., Long, R. W., Nielson, K. R., Eatough, N. L., Wilson, W. E., Eatough, D. J. (2004). Particulate Air Pollution, HRV, and Inflammation. *Environ. Health Perspect.* 112: 339-345.
- Pryor, S., Steyn, D. (1994). Visibility and ambient aerosols in southwestern British Columbia during REVEAL: application of analytical techniques for source apportionment and related visibility impacts of the REVEAL fine particulate optical and scene data. Victoria, BC, Canada: British Columbia Ministry of Environment, Lands and Parks. Available from NTIS, Springfield, VA; MIC-96-00314/NIS.
- Pun, B.K., Seigneur, C., Grosjean, D., Saxena, P. (2000). Gas-phase formation of water-soluble organic compounds in the atmosphere: a retrosynthetic analysis. *J. Atmos. Chem.* 35: 199-223.
- Romieu, I., Meneses, F., Ruiz, S. (1996). Effects of air pollution on the respiratory health of asthmatic children living in Mexico City *Am J Respir Crit Care Med.* 154: 300-307.
- Rosenfeld, D. (1999). TRMM observed first direct evidence of smoke from forest fires inhibiting rainfall. *Geophys. Res. Lett.* 26: 3105-3108.

- Saxena, P., Hildermann, L.M., McMurry, P.H., Seinfeld, J.H. (1995). Organics alter hygroscopic behavior of atmospheric particles. *J. Geophys. Res. [Atmos]* 100: 18,755-18,770.
- Schaefer, G., Hamilton, W., Mathai, C.V. (1997). Implementing the revised NAAQS and the FACA subcommittee for ozone, particulate matter and regional haze. *Environ. Manager*, 22-28.
- Schwartz, J. (1994). Air Pollution and daily mortality: a review and meta analysis. *Environ. Research*. 64: 36-52.
- Schwartz, J., Dockery, D.W., Neas, L.M., (1996). Is daily mortality associated specifically with fine particles. *J. Air & Waste Manage. Associat.* 46: 927-939.
- Seaton, A., MacNee, W., Donaldson, K., Godden, D. (1995). Particulate air pollution and acute health effects. *Lancet* 345:176-178.
- Seinfeld, J. H.; and Pandis, S. N. (1998). *Atmospheric Chemistry and Physics*, John Wiley & Sons Inc, New York, 1996; pp 23-38.
- Sioutas, C., Koutrakis, P., and Burton, R.M. (1994). Development and Evaluation of a Low Cutpoint Virtual Impactor. *Aerosol Sci. Technol.* 21: 223-235.
- Souza, M.B., Saldiva, P.H.N., Pope, C.A. III, Capelozzi, V.L., (1998). Respiratory changes due to long-term exposure to urban levels of air pollution: a histopathologic study in humans. *Chest* 113:1312-18.
- Tang, H., Lewis, E. A., Eatough, D. J., Burton, R. M., and Farber, R. J. (1994). Determination of the particle size distribution and chemical composition of semi-volatile organic compounds in atmospheric fine particles. *Atmos. Environ.* 28: 939-947.
- Terashima, T., Wiggs, B., English, D., Hogg, J.C., VanEeden, S.F. (1997). Phagocytosis of small carbon particles (PM10) by alveolar macrophages stimulates the release of polymorphonuclear leukocytes from bone marrow. *Am. J. Respir. Crit. Care Med.* 155: 1441-1447.
- Turpin, B. J., Huntzicker, J. J., (1995). Identification of secondary organic aerosol episodes and the quantization of primary and secondary aerosol concentrations during SCAQS. *Atmos. Environ.* 29: 3527-3544.
- Turpin, B. J., Huntzicker, J. J., Larson, S. M., Cass, G. R. (1991). Los Angeles summer midday particulate carbon: primary and secondary aerosol. *Environ. Sci. Technol.* 25: 1788-1793.

Turpin, B.J., and Lim, H.J. (2001). Species Contributions to PM_{2.5} Mass Concentrations: Revisiting Common Assumptions for Estimating Organic Mass. *Aerosol Sci. Technol.* 35: 602-610.

U.S. Code. (1990). Clean Air Act, 169B, visibility. U.S.C 42:7492.

U.S. Environmental Protection Agency. (2002). Air Quality Criteria for Particulate Matter, Environmental Protection Agency, Research Triangle Park, NC, EPA/600/P-99/002aC.

Vedal, S., Petkau, J., White, R., Blair, J. (1998). Acute effects of ambient inhalable particles in asthmatic and non-asthmatic children. *Am J Respir Crit Care Med.* 157:1034-1043.

Whitby, K.T., Lui, B.Y.H., Husar, R.B., Barsic, N.J. (1972a). The Minnesota aerosol analyzing system used in the Los Angeles smog. *J. Colloid Interface Sci.* 39:136-164.

Whitby, K.T., Husar, R.B., Lui, B.Y.H. (1972b). The aerosol size distribution of Los Angeles Smog. *J. Colloid Interface Sci.* 39:177-204.

Whitby, K.T. (1978). The physical characteristics of sulfure aerosols. *Atmos. Environ.* 12: 135-159.

Whitby, K.T., Svendrup, G.M. (1980). California aerosols: Their physical and chemical characteristics. *Adv. Environ. Sci. Tech.* 10: 477.

Wilson, R., Spengler, J., (1996). Epidemiology of acute health effects: summary of time-series studies. *Particles Our Outdoor Air: Concentrations and Health Effects*, Ch. 6, 123-148.

Wilson, W.E., Grover, B.D., Long, R.W., Eatough, N.L., Eatough, D.J. The measurement of fine particulate semi-volatile material in urban aerosols. *J. Air Waste. Manage. Assoc.* In Press.

Chapter 2. Characterization and Source Apportionment of Fine Particulate Material in Urban Aerosols. Methodology and Project Information

2.1. Overview

The promulgation of revised standards for atmospheric fine particles by the US EPA has sparked renewed interest in the ability to accurately measure and characterize suspended atmospheric particulate matter. The accuracy of particulate mass and chemical components measurements can not be specifically identified because no calibration standards for atmospheric aerosols exist. Several uncertainties endure relative to the relationship of particles measured on the FRM collection filter compared to the mass and composition of particles suspended in the atmosphere prior to collection. Measurement is complicated by the fact that ambient fine particulate matter is not a single pollutant, but a mixture of many chemical species. Neither an EPA PM_{2.5} FRM or similar single-filter sampler, nor a TEOM monitor can accurately measure the components of PM_{2.5}. These sampling methods suffer from loss of SVM from the collection media. The development of instruments to accurately determine all the components of PM_{2.5} is important. Several studies were conducted to enhance the understanding of atmospheric PM_{2.5}, increase the ability to accurately measure PM_{2.5}, and deduce the major sources of PM_{2.5}.

2.2. Experimental

The accurate determination and characterization of urban aerosols can be considered a daunting task. Several instruments have been developed for the analysis of PM_{2.5} mass and chemical components including both integrated samplers and semi-continuous methods. Integrated samplers require the collection, transport and in-lab

analysis of filter-based collection media. Semi-continuous methods are designed to provide self-sustaining analysis of the species of interest. The instruments used in the studies performed are outlined in the following sections.

2.2.1. Integrated Monitoring Techniques

PM_{2.5} FRM. The PM_{2.5} Federal reference method (FRM) was designed for monitoring networks to provide attainment/non-attainment information for compliance with NAAQS designated standards of PM_{2.5}. A schematic of the sampling system is shown in Figure 2.1. The aerosol is sampled at 16.7 L/min through a inlet equipped with 45° flanges. This inlet protects the monitor from inclement weather and also acts as an initial 50% cut-point for PM₁₀. Following the inlet, a WINS (Well-Impaction Ninety-Six) impactor is used as a PM_{2.5} 50% cut-point to remove particles between 2.5 and 10 μm. Subsequently a single Teflon filter is used, under controlled temperature, pressure and flow rate conditions, for the collection of atmospheric particles. PM_{2.5} mass is determined gravimetrically following protocols that have been extensively described (US EPA 1994). PM_{2.5} mass values determined by the FRM were obtained from the South Coast Air Quality Monitoring District (SCAQMD) in Rubidoux, CA, (Chapter 4) and the California Air Resource Board (CARB) in Fresno, CA (Chapter 6).

PC-BOSS. The combination of technology used in the high-volume Brigham Young University organic sampling system (BIG BOSS) and the Harvard particle concentrator has resulted in the particle concentrator-Brigham Young University organic sampling system (PC-BOSS) (Tang *et al.*, 1994; Sioutas *et al.*, 1994; Ding *et al.*, 2002a;

Figure 2.1. Schematic of the sampling portion of PM_{2.5} Federal reference method.

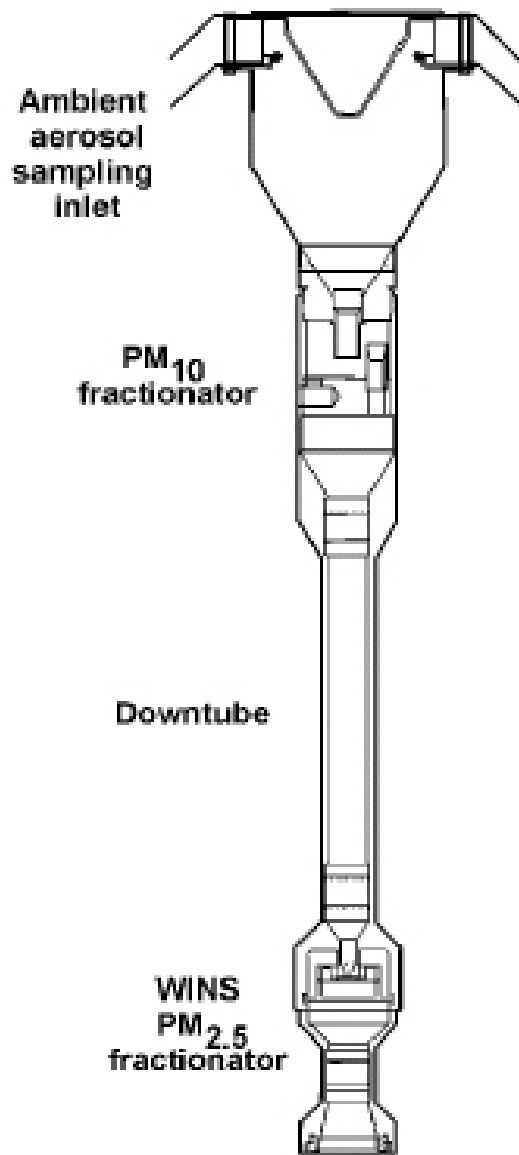

Adapted from Nobel *et al.*, 2001.

Ding *et al.*, 2002b; Lewtas *et al.*, 2001) and a schematic of the PC-BOSS is shown in Figure 2.2.

The PC-BOSS has been used for sample collection to determine fine particulate mass, trace elements, crustal material, sulfate, carbonaceous material (elemental and organic), nitrate, semi-volatile organic material, and semi-volatile nitrate. Samples for the chemical characterization of $PM_{2.5}$ in the minor flow following a particle concentrator and a BOSS diffusion denuder are collected in a filter pack containing a pre-fired 47 mm quartz filter (Pallflex) followed by a 47 mm charcoal impregnated glass fiber filter (CIG, Schleicher and Schuell, Dassell Germnay) to determine fine particulate sulfate, and carbonaceous material and nitrate, including semi-volatile species lost from the particles during sampling. A second parallel filter pack containing a 47 mm Teflon (Whatman) filter followed by a 47 mm Nylon (Gelman, Nylasorb) filter is used to determine $PM_{2.5}$ filter-retained (non-volatile) mass, sulfate and nitrate, plus any semi-volatile nitrate lost from the particles during sample collection. A side flow filter pack, prior to the particle concentrator, containing a 47 mm polycarbonate (Corning, 0.4 μ m pore size) filter followed by a 47 mm CIG filter collects particles (excluding semi-volatile species lost during sampling) and gas phase organic material after the 2.5 μ m inlet cut. These data are compared to data from the minor flow filters to determine the particle concentrator efficiency (Lewtas *et al.*, 2001; Modey *et al.*, 2001; Long *et al.*, 2002). The referenced articles have shown that calculated efficiencies based on sulfate, nonvolatile organic material, and elemental carbon are all comparable. However, for the studies reported in this work, efficiencies were determined using sulfate data. The PC-BOSS filters can also

Figure 2.2. Schematic representation of the PC-BOSS.

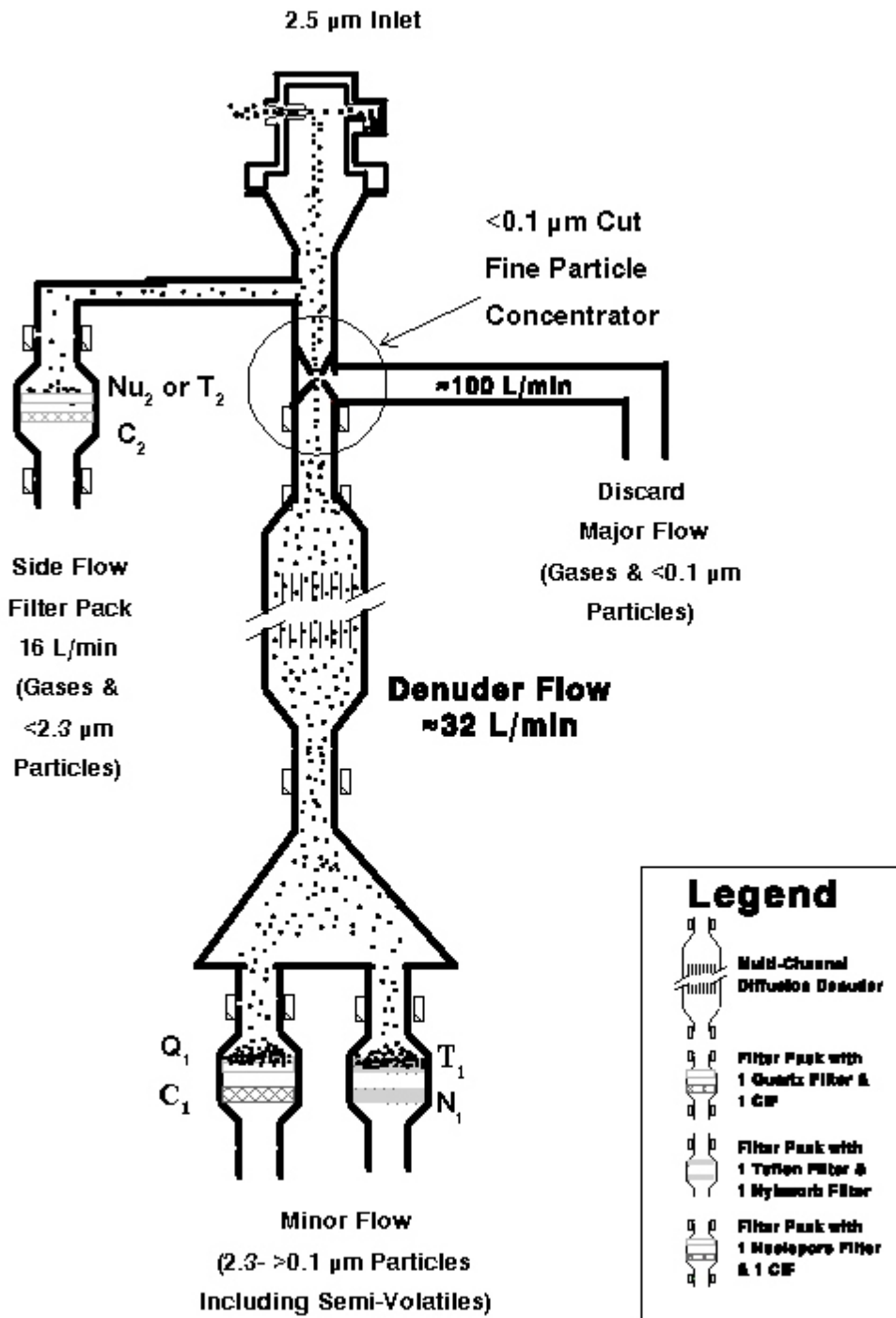

be used to estimate elemental content by PIXE analysis. The concentrations of each chemical species were calculated by the following equation:

$$C_{comp} = \frac{\left(\frac{C_{min}}{Q_{min,fp}} \right) \times \left(\frac{Q_{min,PC}}{Q_{tot,PC}} \right)}{Eff_{PC}} \quad (2.1)$$

where C_{min} is the amount (g) of the chemical component on the minor flow filter and $Q_{min,fp}$ is the total flow (m³) through the minor flow filter pack. The $Q_{min,PC}/Q_{tot,PC}$ term represents the particle concentrator flow adjustment where $Q_{min,PC}$ and $Q_{tot,PC}$ are the minor and total flows (m³) through the particle concentrator, respectively. The particle concentrator efficiency (Eff_{PC}) is calculated as follows:

$$Eff_{PC} = \frac{C_{sulfate, min}}{C_{sulfate, sf}} \quad (2.2)$$

where $C_{sulfate, min}$ is the average sulfate concentration obtained from the quartz and Teflon filters in the PC-BOSS minor flow and $C_{sulfate, sf}$ is the sulfate concentration on the side flow filter. The side flow undenuded component concentrations were calculated as:

$$C_{comp, sf} = \frac{C_{sf}}{Q_{sf}} \quad (2.3)$$

where C_{sf} is the amount (g) of the chemical component on the side flow filter and Q_{sf} is the total flow (m³) through the side flow filter pack.

The PC-BOSS has several advantages over diffusion denuder systems previously used to determine fine particulate SVM. Both semi-volatile nitrate and semi-volatile

organic material are determined simultaneously by the PC-BOSS (Lewtas *et al.*, 2001; Modey *et al.*, 2001; Pang *et al.*, 2002a, b). The use of a particle concentrator eliminates the need for the independent measurement of the efficiency of collection of gas phase organic compounds by the diffusion denuder (Cui *et al.*, 1998; Eatough *et al.*, 1999; Ding *et al.*, 2002 a, b). This elimination of the independent measurement of denuder breakthrough, allows for the PC-BOSS to be used in routine field operation. Also, the effective high sample flow obtained with the particle concentrator allows for the collection of samples over time periods as short as 1-h (Eatough *et al.*, 1999; Long *et al.*, 2002). One disadvantage of the PC-BOSS is the need to collect an additional filter sample to determine the particle concentrator efficiency.

For the study conducted at Lindon, UT, (Chapter 3) a combination of 3-, 8-, and 24-h PC-BOSS samples were obtained. A combination of 1- and 3-h PC-BOSS samples were obtained at Rubidoux, CA (Chapter 4) and 3-h PC-BOSS samples were obtained in Fresno, CA (Chapter 6) and Riverside, CA (Chapter 9).

2.2.2. Semi-Continuous PM_{2.5} Mass Monitoring Techniques

The RAMS. The Real-time total ambient mass sampler (RAMS), based on diffusion denuder, Nafion dryer and TEOM monitor technology, has been developed, field-tested, and validated for the continuous determination of total PM_{2.5} mass, including semi-volatile species (Eatough *et al.*, 2001; 1999; Long *et al.*, 2002; Obeidi and Eatough, 2002; Obeidi *et al.*, 2002; Pang *et al.*, 2002). A schematic representation of the RAMS is given in Figure 2.3. The RAMS measures total PM_{2.5} mass using TEOM monitor technology modified to exploit a “sandwich” filter to retain SVM, which would be lost from particles in a conventional TEOM monitor. The sandwich filter consists of a

Figure 2.3. Schematic of the RAMS.

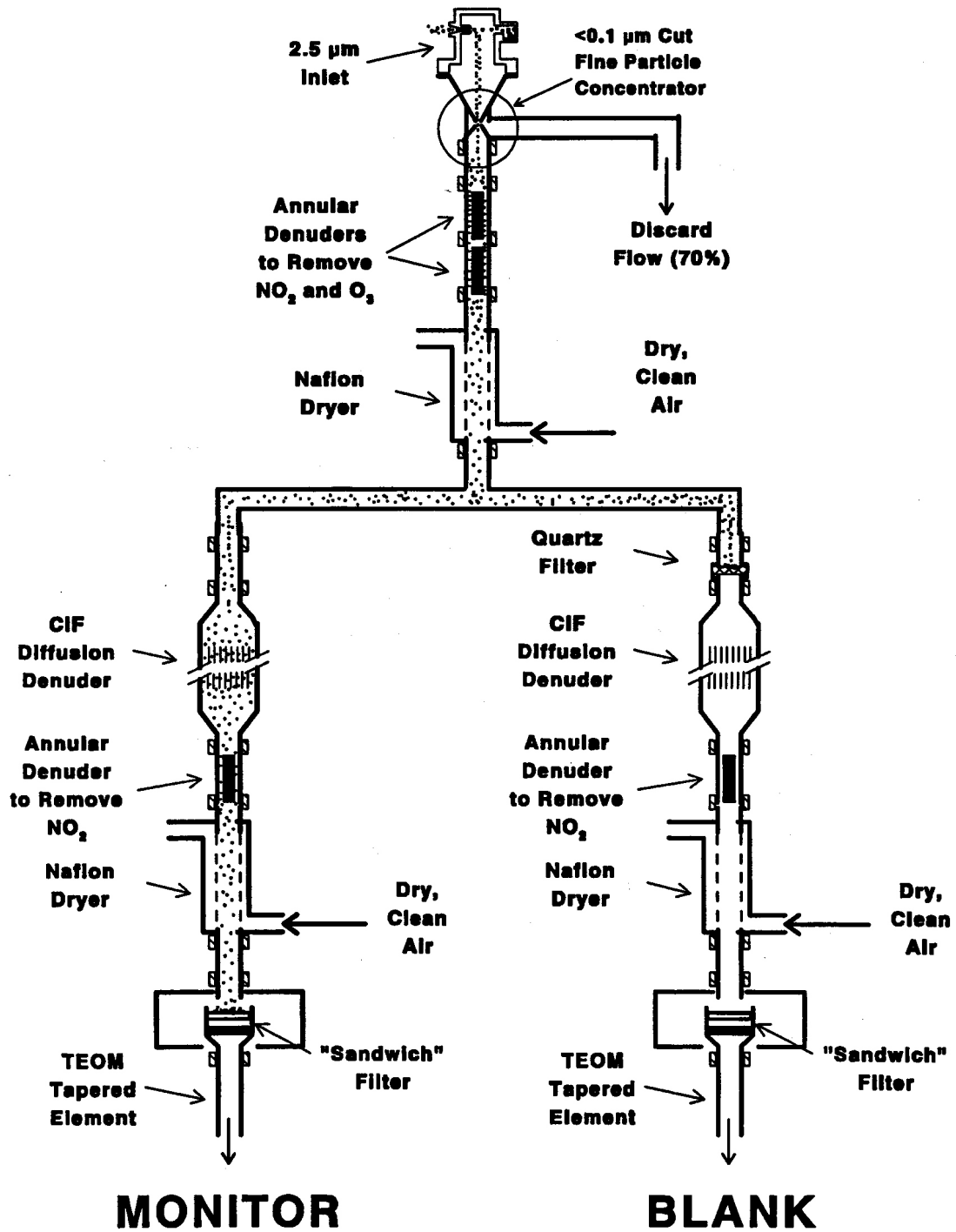

Teflon-coated particle collection filter (R&P TX40) followed by a CIG filter to collect any semi-volatile nitrate and organic compounds lost from the particles during sampling. Care must be taken to remove from the sample stream all gas phase species that can be absorbed by the CIG filter in order to prevent overestimation of PM_{2.5} mass.

The RAMS has a dual inlet system consisting of an R&P 2.5 m sharp cut cyclone inlet followed by a one stage particle concentrator to separate fine particles from coarse particles and from 70 % of the sampled gas stream. Total inlet flow is 16.7 L/min. The major flow of the particle concentrator is 11.7 L/min, and the minor flow for the concentrated particle stream is 5.0 L/min, 30% of the total flow. The concentrated aerosol is passed through two triethanolamine (TEA) coated multi-annular denuders (University Research Glass) to remove NO₂, and through a 1-ft long, 200 element Nafion dryer (Perma Pure, Model PD-750-12) to remove gas-phase and particle bound water. The flow is then split into two 2.5 L/min streams. A filter is placed in one of the streams to provide a particle-free gas stream for a subsequent active blank filter. The blank and particle measurement streams each then enter a BOSS denuder to remove gas phase organic material, O₃, SO₂, and HNO₃ (Obeidi and Eatough, 2002). Finally, each sample flow is passed through a second TEA coated annular denuder and Nafion dryer to remove any NO₂ formed from NO in the BOSS denuder (Obeidi and Eatough, 2002) and any gas phase water stored during high relative humidity periods and released during low relative humidity periods by the BOSS denuders. The measurement and blank minor flows are then each monitored with separate TEOM monitors. The blank system corrects for any gas phase species which will be sorbed by the CIG of the TEOM “sandwich filter” but

which are not removed by the various denuders and dryers. The $PM_{2.5}$ mass is then calculated using the following equation:

$$PM_{2.5} = \frac{((RAMS - Blank) - Blank_{corr}) \times \left(\frac{Q_{min, pc}}{Q_{tot, pc}} \right)}{Eff_{PC}} \quad (2.4)$$

where the RAMS and Blank terms are the concentrations of $PM_{2.5}$ in g/m^3 measured on the respective TEOM monitors. The $Blank_{corr}$ term accounts for the difference in residence time caused by the in-line filter placed in the blank side of the RAMS monitor as described above. This term is multiplied by a flow adjustment term ($Q_{min,pc}/Q_{tot,pc}$) where $Q_{min,pc}$ and $Q_{tot,pc}$ are the minor flow and total flow through the particle concentrator respectively. The Eff_{PC} term is the particle concentrator efficiency. The efficiency of the particle concentrator (Ding *et al.*, 2002a; Eatough *et al.*, 1999) is determined from analysis of sulfate on the in-line filter of the blank monitor and a filter placed in the discard flow of the particle concentrator.

The RAMS was used to determine 1-h averaged $PM_{2.5}$ total mass concentrations, including SVM, for studies conducted in Lindon, UT (Chapter 3), and Rubidoux, CA (Chapter 4). One-min averaged total $PM_{2.5}$ concentrations were determined with the RAMS on an environmental exposure facility (Chapter 10).

R&P TEOM Monitor. The Rupprecht and Patashnick (R&P) Tapered Element Oscillating Microbalance (TEOM) is a resonance frequency instrument. A quartz (TX40) filter is placed on the tip of a hollow glass oscillator which oscillates at a designated frequency induced by a magnetic field. The aerosol is sampled through the tip of the oscillator. As particles are deposited on the filter (m), the frequency of

oscillation changes (ω) such that:

$$\omega = \sqrt{m/m} \quad (2.5)$$

where ω is the frequency of vibration and m is the mass of the active part of the oscillator.

A schematic of the mass transducer portion of the TEOM monitor is given in Figure 2.4. Because atmospheric particles are often highly hygroscopic, the TEOM heats the aerosol to 50 °C, under standard operating conditions, to remove particle bound water. Under these conditions, semi-volatile species are not retained on the collection filter (Mignacca and Stubbs, 1999). Subsequently, the TEOM monitor only measures non-volatile PM (Grover *et al.*, 2005; Long *et al.*, 2002). The TEOM monitor was used in Lindon, UT, Rubidoux, CA, Fresno, CA and Riverside, CA to obtain 1-h averaged concentrations of non-volatile PM_{2.5} mass.

R&P FDMS. The Rupprecht and Patashnick Filter Dynamics Measurement System (FDMS) 8500 has been designed to measure total PM_{2.5} mass including both the non-volatile and semi-volatile fractions using TEOM technology. A schematic of the FDMS is shown in Figure 2.5. Ambient air is sampled through an R&P 2.5 μm sharp-cut inlet. The aerosol then passes through a sample equilibration system (SES) Nafion diffusion dryer to remove particle bound water. The main flow is subsequently split into a base flow and a reference flow every 6-min using a switching valve. The base flow is sampled directly through a TX40 filter on a TEOM microbalance providing a direct measurement of particulate matter deposited on the filter. After 6-min, the flow is directed to a reference flow in which the air stream is sampled through a 47 mm quartz

Figure 2.4. Schematic of the microbalance portion of the R&P TEOM monitor.

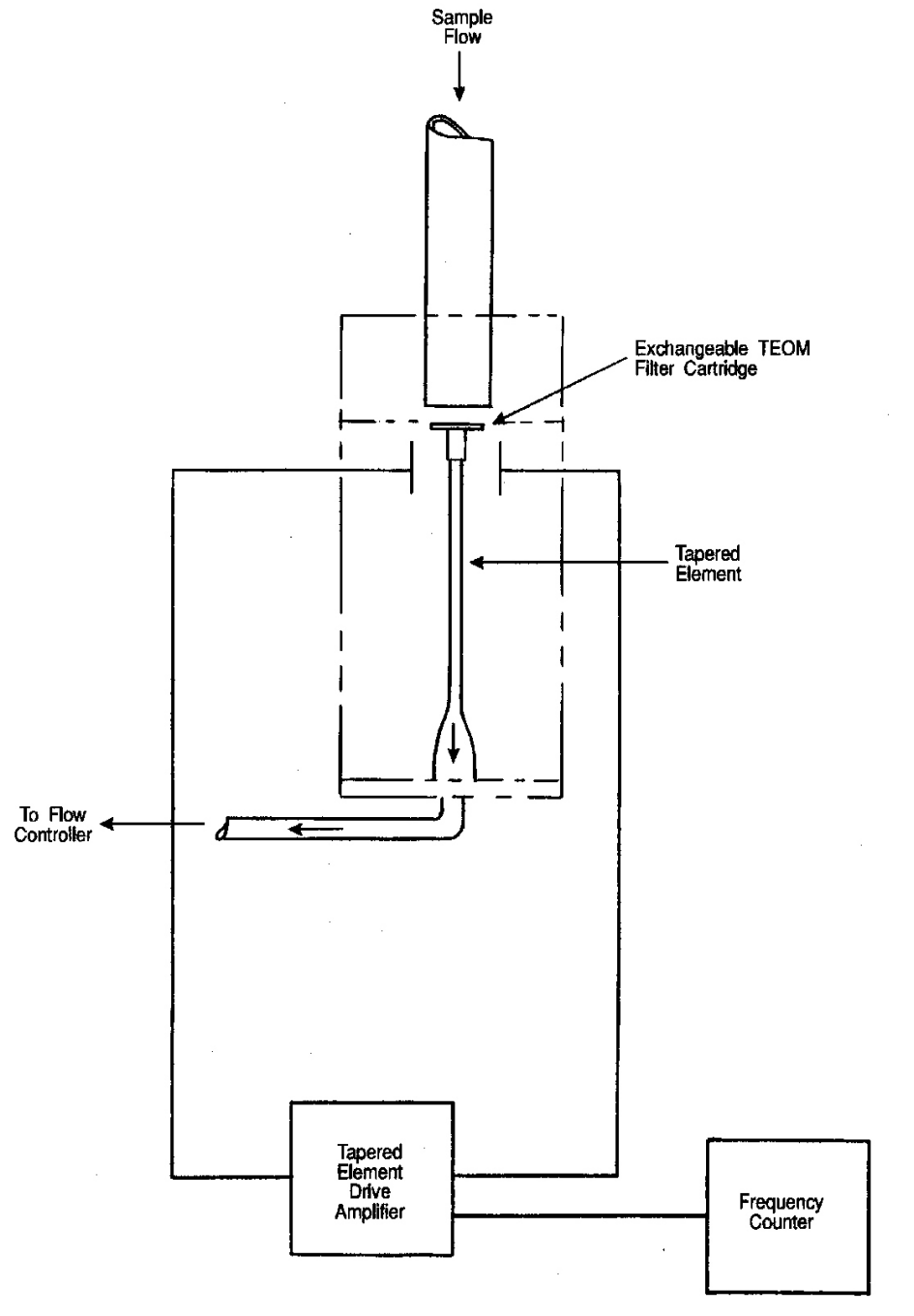

Adapted from Rupprecht & Patashnick Co., Inc. 1996.

Figure 2.5. Schematic of the R&P Filter Dynamic Measurement System.

System Schematic

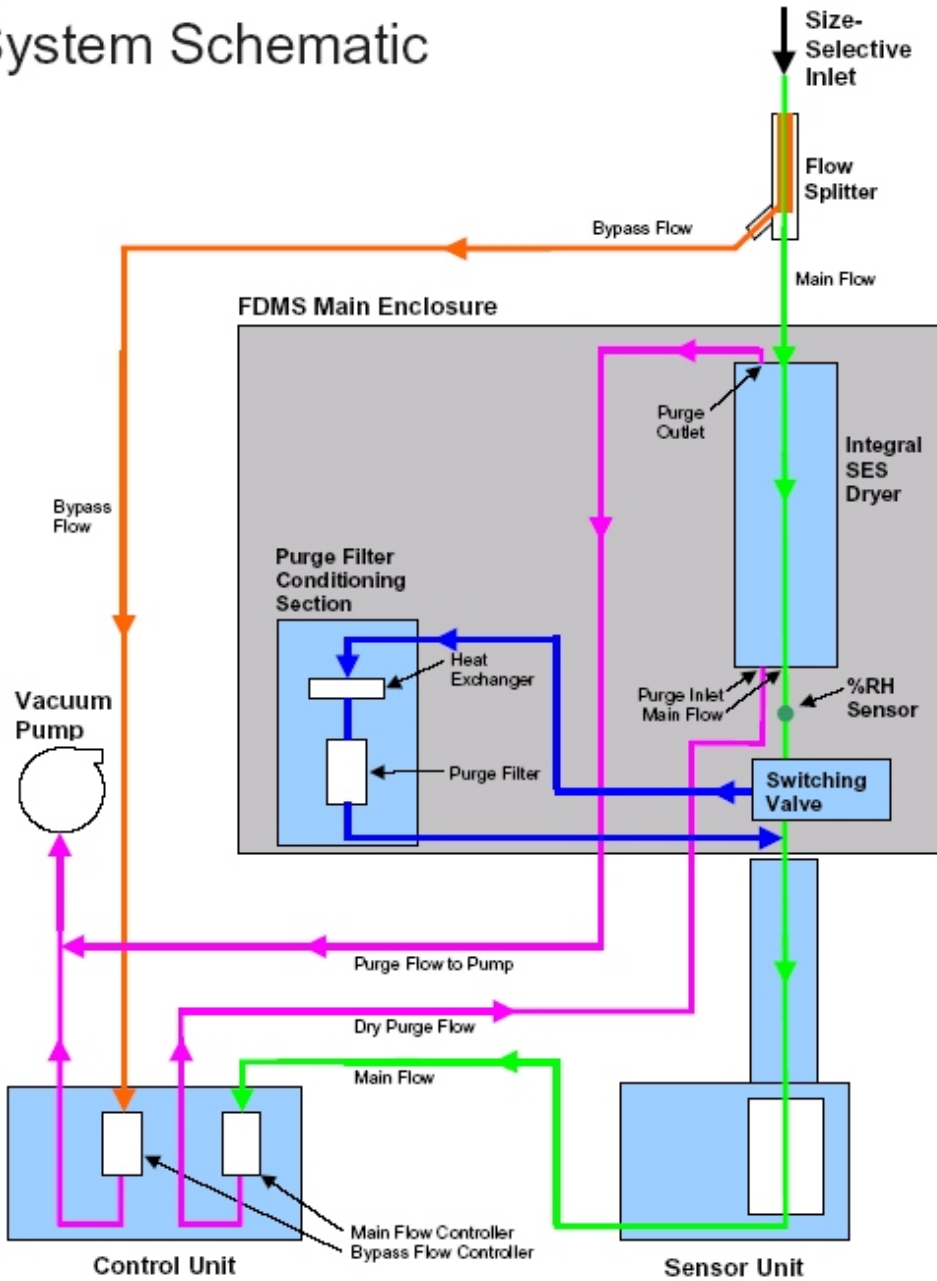

Adapted from Rupprecht & Patashnick Co., Inc 2003

purge filter, maintained at 4°C, to remove particles in the sampled aerosol. The reference flow then is directed to the TX40 filter in the TEOM mass sensor unit providing a direct mass measurement of particle-free air. The reference flow mass measurement is then used to adjust the mass concentration of the base flow measurement. For example, if a negative mass is measured during the reference flow cycle, due to loss of SVM from the TX40 filter, this mass is added to the mass measurement made during the initial base flow (particle-laden) measurement.

The FDMS monitor was initially validated for the measurement of 1-h averaged total PM_{2.5} mass concentrations during studies in Lindon, UT and Rubidoux, CA. Subsequently, the FDMS was used to measure 1-h averaged total PM_{2.5} mass concentrations in Fresno, CA, and Riverside, CA. The reference flow measurement can also be used to estimate the amount of SVM lost from the TX40 filter during the purge air cycle.

R&P Differential TEOM. The Differential TEOM is similar in method to the R&P FDMS 8500 unit and was developed primarily as a research instrument. A schematic of the operational portion of the Differential TEOM is given in Figure 2.6. An electrostatic precipitator (Meyer *et al.*, 2002; Yi *et al.*, 2004) is used in place of the chilled filter (R&P FDMS) to remove particles during the 6-min reference purge cycle. Similar to the FDMS, during the purge cycle SVM is lost from the TX40 collection filter and measured as a negative mass. This measured negative mass is then added back on to the mass measured during the collection cycle to determine total PM_{2.5} concentrations.

Collocated Differential TEOMs were used in studies conducted in Riverside, CA, and Fresno, CA. One-h averaged concentrations of total (nonvolatile plus semi-volatile)

Figure 2.6. Schematic of the R&P differential TEOM monitor.

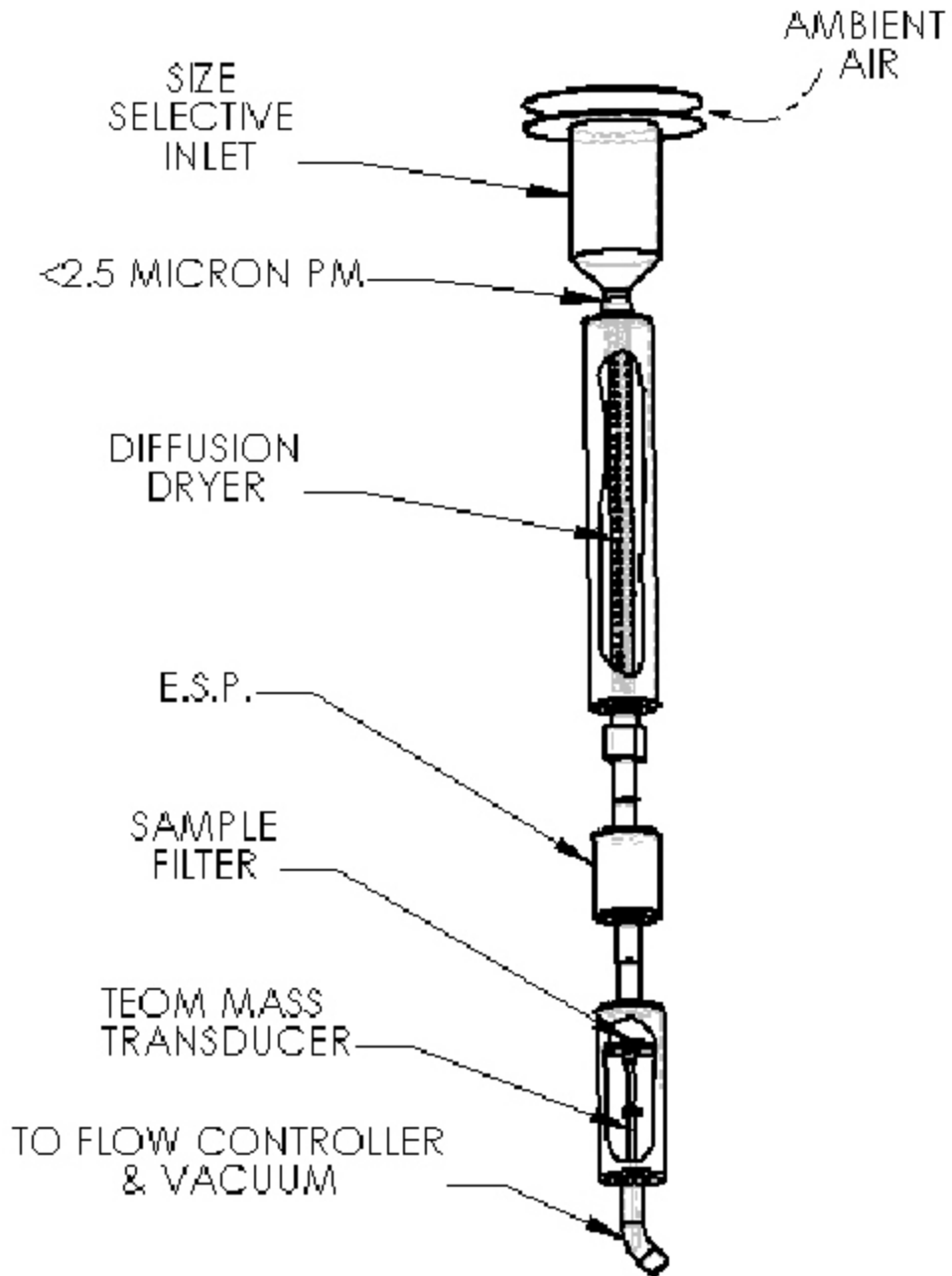

Adapted from Yi *et al.*, 2004

PM_{2.5} mass were measured for comparison with other mass measurement techniques, particularly the FDMS monitor.

GRIMM Model 1100 Monitor. This unit uses a semiconductor laser as a light source to monitor light scattering of single particles. An internal volume controlled pump is used to sample the ambient aerosol at a rate of 1.2 L/min. This pump also is used to generate a clean sheath air which is filtered and subsequently passed through a sheath air regulator to the optical chamber. The sheath air is used: 1) to prevent dust contamination in the laser-optic assembly and 2) as a reference zero test during the auto-calibration procedure. As single particles pass through the laser beam in the optical chamber, light scattering occurs and is collimated by a mirror located approximately 90° from the laser source and subsequently measured by a recipient diode. Following a corresponding amplification, the signal of the diode is recorded with a multi-channel size classifier. A pulse height analyzer then classifies the transmitted signal in each channel which is sent to the data storage card for analysis. Conversion from the measured particle volume to mass distribution is done using protocols developed by GRIMM Technologies. A schematic of the optical portion of the GRIMM monitor is shown in Figure 2.7.

The conventional GRIMM monitor measures particles at ambient temperature. A collocated GRIMM monitor was also applied in the studies described which used an inlet equipped with a heater operated at 80 °C, resulting in a temperature of 50 °C in the laser measured aerosol for comparison with heated TEOM mass data.

Met One Instruments Beta Attenuation Mass (BAM) Monitor. The attenuation of β -particle beams as they pass through a filter can be used to measure

Figure 2.7. Schematic of the optical portion of the GRIMM monitor.

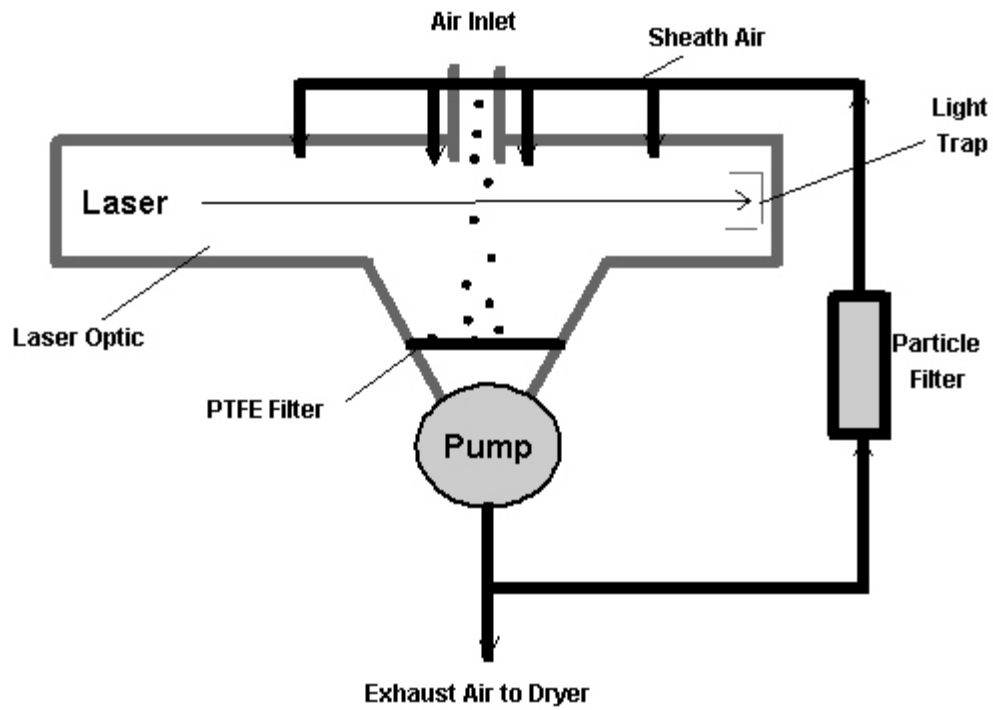

ambient PM concentrations. In the BAM monitor, particles are deposited on a continuous glass fiber type tape. A ^{14}C beta source and a beta detector are used to measure β -ray attenuation following the deposition of aerosol PM on the glass-fiber filter tape. A schematic of a typical β -ray attenuation device is given in Figure 2.8. Prior to sample collection, baseline β -ray attenuation values are obtained. Subsequently, β -ray attenuation is re-measured following the collection of PM on the filter tape to determine mass concentrations of $\text{PM}_{2.5}$. The ratio of β -rays through a clean and loaded filter is used to determine PM mass concentrations by applying a Beer-Lambert type relationship:

$$\ln(I_0/I) = (\mu_m) X \quad (2.6)$$

where I_0 is the β -ray intensity through a clean portion of the filter, I is the intensity of β -rays through the loaded filter, X is the thickness of the particles on the loaded portion of the filter, and (μ_m) is a constant known as the mass adsorption coefficient. It is assumed that (μ_m) is independent of the type of particles deposited on the filter. The mass per unit area of loaded filter $(\mu_m X)$ is therefore directly related to $\ln(I_0/I)$. An automated advanced microprocessor system is used to obtain semi-continuous measurements by advancing the filter tape following each sampling period and drift is avoided because the baseline β -ray attenuation is measured before each sampling period (Chung *et al.*, 2001).

Concentrations of 1-h averaged $\text{PM}_{2.5}$ mass were made with a BAM monitor during the study conducted in Fresno, CA (Chapter 6). The BAM monitor was operated at the EPA Fresno Supersite by the CARB.

Figure 2.8. Schematic of a typical β -ray attenuation device for the measurement of atmospheric particles.

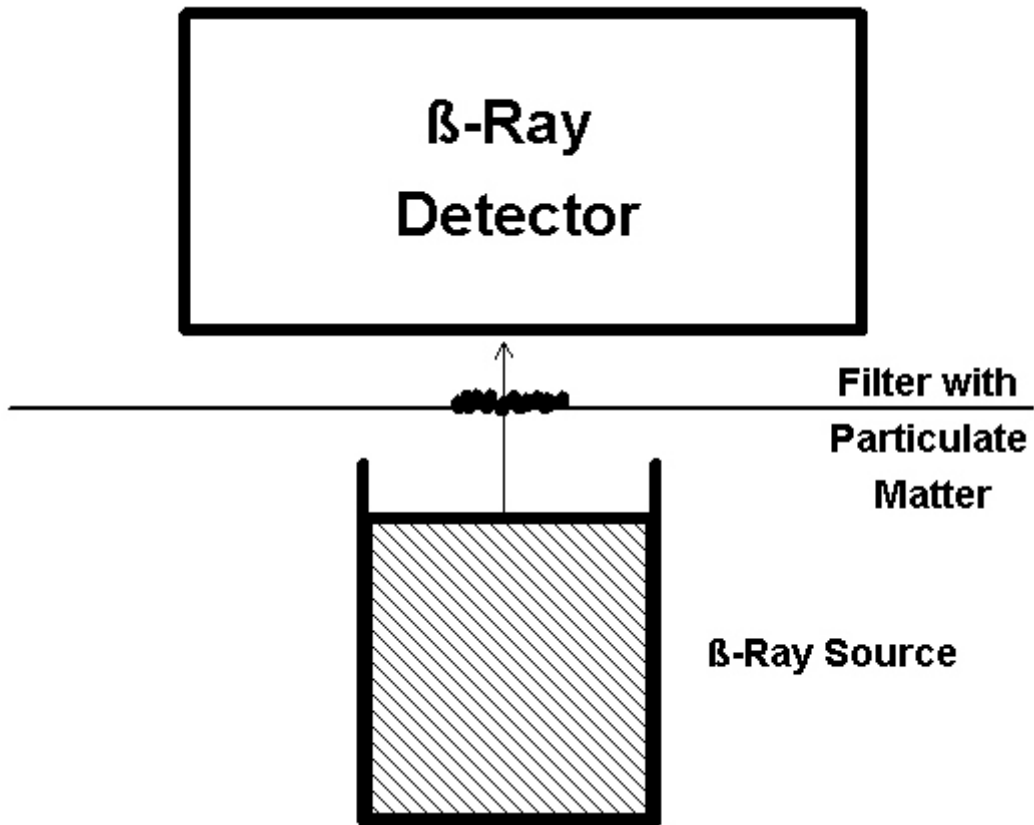

Adapted from Finlayson-Pitts and Pitts 1999.

2.2.3. Semi-Continuous Chemical Species Monitoring Techniques

R&P Series 5400 Ambient Carbon Particulate Monitor. This instrument performs a thermal-CO₂ analysis to determine hourly carbon concentrations present in a sample collected on an impactor. During the analysis phase the collected sample is first heated to 375 °C to determine OC and then to 750 °C to determine total carbon (TC) concentrations. Elemental carbon (EC) is determined by the difference between the TC and the OC measurements. The low temperature evolved carbon was assumed to be organic material. One-h averaged carbon concentrations using the R&P 5400 were obtained by both an instrument operated by Brigham Young University and one operated by the EPA Fresno Supersite during the study conducted in Fresno, CA (Chapter 6). It was assumed that fine particulate organic material was 62% carbon, typical of an aged urban aerosol (Turpin and Lim, 2001) for this study.

Sunset Laboratory Carbon Monitor. This instrument is a semi-continuous thermal/optical transmission (TOT) method for the measurement of particulate carbon. A 2.5 m sharp-cut cyclone inlet (R&P) is used with a total flow of 8 L/min. An in-line parallel plate charcoal impregnated filter denuder, similar to that used in the RAMS (Eatough *et al.*, 1999), is used to remove gas phase organic compounds in the aerosol. The denuder reduces the effects of positive artifacts caused by the absorption of gas-phase organic species on the quartz collection filter. The air stream is sampled on a 12.3 mm diameter quartz filter for a designated time period (normally 45-min), followed by a 15-min analysis to yield an estimate of a 1-h average. Sample collection is then interrupted and the sample analyzed, using a (TOT) method similar to the NIOSH

Method 5040. Initially OC concentrations are determined by heating the filter in a pure helium atmosphere to temperatures of 250, 500, 650 and 850 °C. A 98% helium 2% oxygen atmosphere is used in the second stage and the filter is heated to temperatures of 650, 750 and 850 °C to determine EC concentrations. As organic material is heated in an inert atmosphere, pyrolyzation of organic material can occur. Pyrolyzed carbon is corrected for in this technique based on the transmission of a laser (Birch and Cary, 1996) through the quartz filter. Carbon thermally evolved from the filter is converted to CO₂ in a manganese dioxide catalyst and detected by a non-dispersive infrared detector (NDIR). Each sample analysis is followed by a calibration step.

One-h averaged concentrations of OC and EC were determined by a Sunset Laboratory carbon monitor in Rubidoux, CA (Chapter 4) and Fresno, CA (Chapter 6). Modifications to the Sunset Laboratory carbon monitor were made to allow for the 1-h averaged determination of semi-volatile carbonaceous species as discussed in Chapters 4 and 8. The results of these studies led to the development of a dual-oven Sunset carbon monitor (Chapter 8) which was field tested in Riverside, CA (Chapter 9).

Anderson Aethalometer. In the Aethalometer, the attenuation of light through a fibrous filter is used to measure concentrations of elemental carbon. A high intensity light emitting diode (LED) at 880 nm is used as a light source. The concentration of EC deposited on the filter can be determined by the amount of attenuation of the light source as follows:

$$ATN(\lambda) = s(1/\lambda) [EC] \quad (2.7)$$

where the attenuation of light, $ATN(\lambda)$, at a specific wavelength (λ) is related to the concentration of EC deposited on the filter $[EC]$ multiplied by the optical absorption cross-section, $s(\lambda)$, referred to as “specific attenuation” (Hansen 2002). A second ultraviolet (UV) wavelength operating at 370 nm is also used in the Aethalometer. Certain organic compounds associated with diesel emissions, environmental tobacco smoke, and polycyclic aromatic hydrocarbons (PAHs) exhibit strong UV absorbance (Hansen 2002). This UV specific absorption can be detected but cannot be quantified because each of the many compounds that absorb in the UV will have a different UV absorption efficiency. However, this UV measurement can be used as an estimate of the amount of UV absorbing species present in the aerosol which can be used in source apportionment techniques to elucidate diesel fuel emissions sources (Chapters 3, 5).

One-h averaged concentrations of EC and UV absorption using an Anderson Aethalometer were determined in Lindon, UT (Chapter 3), Rubidoux, CA (Chapter 4), Fresno, CA (Chapter 6) and Riverside, CA (Chapter 9). Furthermore, these measurements were used in source apportionment techniques as outlined in Chapters 3 and 5.

Fine Particulate Inorganic Soluble Ion Monitor. The development of instrumentation for the measurement of atmospheric inorganic particulate composition has been recently reviewed (Dasgupta and Poruthoor, 2002). The instrument used in this study was developed at Texas Tech University (TTU) and has recently been commercialized by Dionex Corporation. The air sample is first passed through a cyclone with a 50% cutpoint at 2.5 μm flowing at 5 L/min and then proceeds through a parallel

plate wet denuder using 0.5 mM hydrogen peroxide as the scrubber liquid; this removes soluble gases, notably sulfur dioxide, nitric acid, and ammonia (Boring *et al.*, 2002). Air exiting the denuder enters the annular channel of a concentric nozzle, and deionized water is pumped into the center tube using a peristaltic pump. The liquid generates a spray that attaches to the aerosol particles. The flow is ultimately drawn out through a 0.5 μm pore size PTFE filter. Liquid droplets coalesce and fall below. The liquid is aspirated by a peristaltic pump and sent to a Dionex TAC-ULP preconcentration column of an ion chromatograph (IC) for anion analysis and a Dionex TCC-ULP preconcentration column for cation analysis. Anion analysis is performed using an IonPac AG11-HC guard column and an IonPac AS11-AC column with 15-min chromatographic cycles largely following protocols described previously (Dasgupta and Poruthoor, 2002; Al-Horr *et al.*, 2003). The system can collect particles down to 100 nm aerodynamic diameter with high efficiency. This technology has been field tested in Philadelphia, PA in the summer of 2001 and in Tampa, FL in the summer of 2002.

Concentrations of sulfate, nitrate and ammonium ion were determined in Lindon, UT, (Chapter 3) with a TTU instrument. The Dionex gas-particle (GP-IC) commercialized version of the TTU instrument was field tested for the first time in Fresno, CA (Chapter 6). Sulfate, nitrate and ammonium ion concentrations were determined with a 15 min time resolution throughout the study. Half-h averaged concentrations of sulfate and nitrate were measured with a TTU instrument at Riverside, CA (Chapter 9).

R&P Series 8400N Nitrate Monitor. In this method, the aerosol is sampled through a 2.5 m cyclone inlet, passed through a charcoal honeycomb denuder to remove

interfering nitric acid, humidified in a Nafion tube to increase collection efficiency, and collected on a nickel-chrome impaction strip. Following collection, the sample is flash vaporized and nitrate concentrations are measured by a NO_x pulse analyzer (Stolzenburg and Hering, 2000). Hourly-averaged concentrations of nitrate were determined with a R&P 8400N nitrate monitor in Rubidoux, CA, (Chapter 4) and Fresno, CA (Chapter 6).

R&P Series 8400S Sulfate Monitor. This system operates under a similar flash vaporization technology to that used in the R&P nitrate monitor. The aerosol is drawn first through a 2.5 m cyclone and then passes through an activated carbon denuder to remove interfering gases. A Nafion humidifying system is used to humidify the particle-laden aerosol to increase collection efficiency of PM on the impactor. Following collection, flash vaporization of the aerosol particles with temperature exceeding 600 °C occurs producing SO_2 which is subsequently measured using a SO_2 -pulsed fluorescence sensor. A R&P 8400S sulfate monitor was operated by the CARB at the EPA Fresno Supersite for the determination of 1-h averaged concentrations of sulfate at Fresno, CA (Chapter 6).

2.2.4. Particle Size Distribution and Count

TSI SMPS/CPC. The TSI scanning mobility particle sizer (SMPS)/condensation particle counter (CPC) is a real-time instrument that measures the size distribution of particles based on the mobility of charged particles in an electric field. Particle counting is normally performed by a light scattering technique. The polydispersed aerosol enters a bipolar charger that uses ^{85}Kr to expose particles to a high concentration of bipolar ions. A state of equilibrium is reached in which the particles

acquire a charge that is related to size. The aerosol passes into a differential mobility analyzer (DMA) with a sheath air and travel along the wall of the DMA cylinder as shown in Figure 2.9. The positively charged particles are attracted through the sheath air towards a negative collection rod in the DMA cylinder and are precipitated along the collection rod following the equation:

$$Z_p = \frac{neC}{3\pi\mu D_p} \quad (2.8)$$

where Z_p is the electrical mobility of the particle in the charged field, n is the number of elementary charges on the particle, e is the elemental charge, C is the Cunningham slip correction of the particle, μ is the gas viscosity, and D_p is the particle diameter (Knutson and Whitby 1975). Particles with a high electric mobility are precipitated along the top of the collection rod, particles with a low mobility are removed at the bottom of the collection, and only particles with a narrow range of electric mobility exit through a small slit at the bottom of the DMA cylinder. The monodispersed aerosol exiting the bottom of the DMA cylinder is counted by a CPC. In the CPC, the aerosol passes over a heated pool of alcohol resulting in a vapor-saturated air sample. The sample is then directed to a condenser tube where the vapor is cooled by thermal diffusion, resulting in condensation of the alcohol vapor on the aerosol particles. These droplets grow to approximately 10-15 μm and are subsequently directed into the optical detector which consists of a laser diode, collimating lens, and a cylindrical lens. Light scattering that occurs as the droplets pass through the laser light is collected at 90° by a pair of aspheric lenses and focused onto the photodiode for detection (Keady *et al.*, 1984).

Figure 2.9. Schematic of the differential mobility analyzer cylinder model Long DMA 3081.

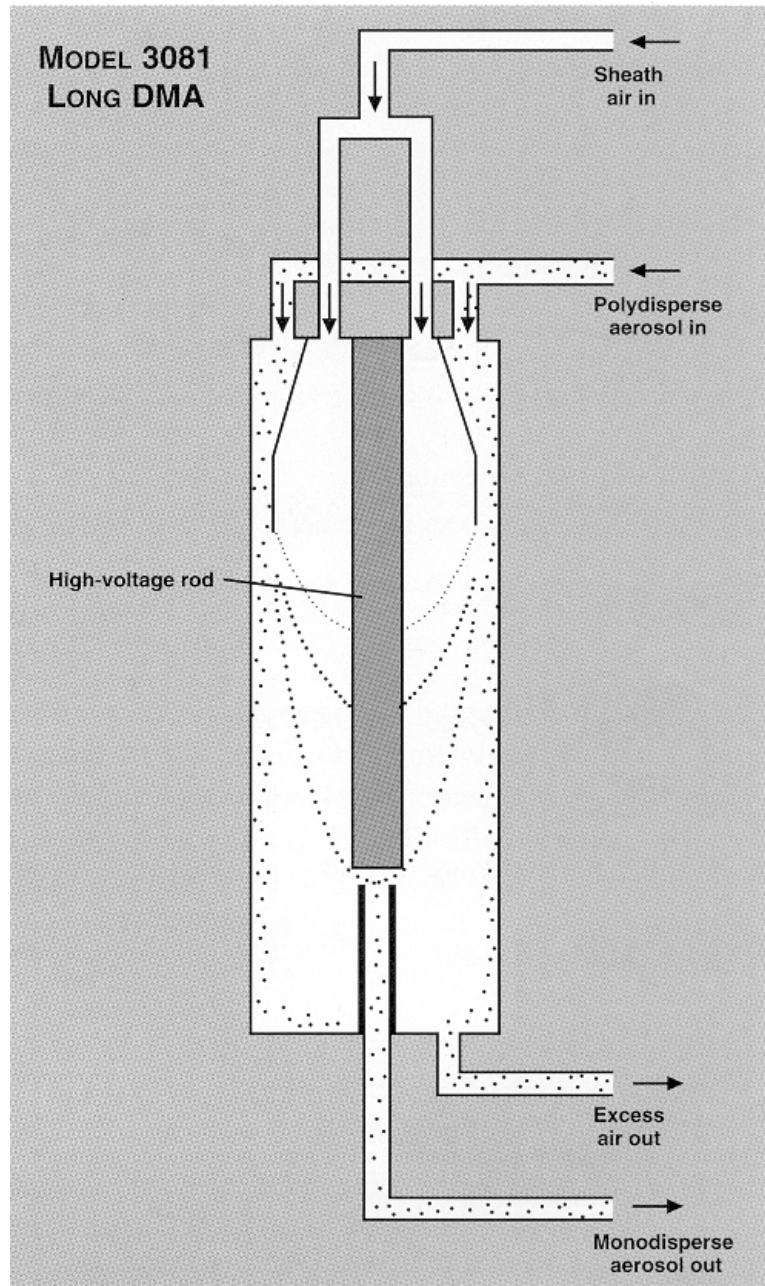

Adapted from Agarwal and Sem 1978

The TSI SMPS/CPC was used in chamber studies (Chapter 9) to measure particle size distributions and particle count. Since the SMPS/CPC is a real-time instrument, particle count numbers were averaged over 1-min time periods for comparison with other analytical techniques.

2.2.5. Gas Phase Data

Gas phase data were used synergistically with $PM_{2.5}$ data to deduce sources of ambient aerosols in several studies. For the study conducted at Lindon, UT (Chapter 3) hourly-averaged concentrations of CO, NO_x and NO_2 were measured with instruments provided by the State of Utah Air Quality Division. O_3 was measured using a UV photometric dual beam instrument (Dasibi 1003 AH) and H_2O_2 concentrations were determined using a diffusion scrubber based fluorometric instrument (Li and Dasgupta, 2000). For the Rubidoux, CA and Fresno, CA studies, 1-h average concentrations of CO, NO, NO_2 , NO_x and O_3 were provided by the South Coast Air Quality Monitoring District (SCAQMD) and California Air Resource Board at the EPA Fresno Supersite, respectively.

2.3. Laboratory Analysis Methods

As previously discussed, one of the main disadvantages of integrated samplers is the time required for in-lab analysis. Care must be taken to extradiate and treat the collection filters appropriately to avoid contamination or modification of the particles collected on the filters. Collected filters were stored in a -30°C freezer prior to analysis. The following analytical techniques were used in the analysis of PC-BOSS filters following validated protocols.

Mettler UMT2 Microbalance. Particulate mass was determined from the Teflon filter sampled from the PC-BOSS minor flow. A pre- and post-weight mass is determined under conditions of controlled temperature and humidity. Deposited particulate mass was determined from the difference between the pre and post-weight mass.

TPV Analysis. Temperature programmed volatilization (Tang *et al.*, 1994; Ellis and Novakov, 1982) was used in the analysis of quartz and CIG filters collected from the PC-BOSS. The quartz filter was analyzed for EC and OC, and the CIG filter for SVOC. Prior to application in the PC-BOSS, the quartz filters are pre-fired in an inert atmosphere to 800 °C for approximately 8-h to remove all carbonaceous impurities. The CIG filters are pre-fired at 425 °C in an N₂ atmosphere for approximately 24-h. In this method, the various sample filters are heated from ambient temperature at a predetermined ramp rate to a predetermined termination temperature. The ramp rate and termination temperatures are dependent on the type of filter being analyzed. Quartz filters are heated to 800 °C in an N₂/O₂ atmosphere. Charcoal impregnated filters are heated to 425 °C in an N₂ atmosphere. Carbon in compounds desorbed from the filters during the heating process is catalytically converted to CO₂ and detected by NDIR. The NDIR was calibrated daily with three certified standards of CO₂ in a zero (N₂) air. Benzoic acid standards were also run periodically for further validation of the calibrations.

Dionex Ion Chromatograph. Ion chromatography (IC) has become one of the most widely used applications for the analysis of soluble inorganic ions in atmospheric particles. Sulfate and nitrate concentrations were determined from the quartz, Teflon,

nucleopore, and nylon filters of the PC-BOSS using IC. The quartz, Teflon, and nucleopore filters were extracted ultrasonically in 5 mL, 10 mL, and 10 mL H₂O, respectively. Nylon filters were extracted in 10 mL of a 3.5 mM Na₂CO₃/1.0 mM NaHCO₃ eluent solution. A Dionex Model 500 ion chromatograph equipped with an AG14 guard column, an IonPac[®] AS 14 analytical column, an ASRS Ultra II self-regenerating suppressor column, and a DS3 conductivity detector was used for the analysis of extracted solutions from the collected filters. The eluent used in the analysis was 3.5 mM Na₂CO₃/1.0 mM NaHCO₃. The concentrations of sulfate and nitrate in the various solutions were determined by peak area measurement and comparison to daily standards. External standards were used to check the calibration of the conductivity detector periodically.

2.4. Source Apportionment of Ambient Aerosols

Particles in the atmosphere normally have a specific chemical “source fingerprint” that can be related to the emitting source of the particle and/or the atmospheric formation process. By measuring the chemical components of particles, one can retrospectively deduce the sources of the particles and the amount that each source contributed to the measured aerosol. These approaches are called “receptor models” and many different types of these models exist. Receptor models use a variety of specific multivariate analysis methods that utilize the composition of an aerosol, measured at a sampling site, to construe source types and contributions. A comprehensive list with the advantages and disadvantages of the many types of receptor models can be found in Watson and Chow 2002. For the studies conducted, two different types of source

apportionment techniques were used, including EPA UNMIX and positive matrix factorization (PMF).

EPA UNMIX. It has previously been shown that the combination of the $PM_{2.5}$ mass and composition data, coupled with the gaseous data, can be used to identify the major sources of fine particulate material (Eatough *et al.*, 2003; Long, 2002; Long *et al.*, 2003; Grover *et al.*, in press) using the EPA UNMIX program (Henry and Norris, 2001). UNMIX can be used to estimate the number of sources, source compositions and source contributions from an ambient data set (Willis *et al.*, 2001; Lewis *et al.*, 2003) UNMIX is a factor analysis technique that generates only source contributions and profiles that are nonnegative or “real,” a problem which plagues traditional factor analysis techniques. Two algorithms are used in UNMIX. The first algorithm uses signal-to-noise considerations to determine the number of sources that can be resolved from the ambient data set. The second defines source hyperplanes or “edges” in the input data, which are related to contributions and compositions of each of the sources defined (Lewis *et al.*, 2003). Uncertainties in the source contributions and compositions are estimated by the UNMIX program by re-sampling the data set multiple times. Each time the data set is re-sampled, new source hyperplanes are identified and their resulting source contributions and profiles are found. The estimate of the uncertainty of 1 sigma is obtained by the standard deviation of these re-sampled results (Lewis *et al.*, 2003).

Several ambient species can be used to predict source contributions. Secondary aerosol species, such as ozone and hydrogen peroxide, can be related to secondary source profiles. Elemental carbon and UV adsorption obtained from an Anderson Aethalometer can be used to predict primary diesel emissions. Nitrogen oxides have been used as

good markers for primary automobile emissions. Also, primary wood smoke emissions and automobile emissions can be identified using carbon monoxide as a marker. EPA UNMIX was used to determine sources of PM_{2.5} from a sampling campaign conducted in Lindon, UT (Chapter 3).

Positive Matrix Factorization (PMF). PMF has commonly been used to deduce source contributions to measured PM_{2.5} mass (Zheng *et al.*, 2004; Kim, *et al.*, 2003). A recently developed positive matrix factorization program, PMF2, allows for source determination using a least squares approach to solve the factor analysis problem. Solutions are forced to be nonnegative and estimates in the measurement error are used as weighting parameters for individual data points. A linear combination of a source matrix and an error estimate matrix is employed.

PMF2, and the algorithm used in the analysis, has been previously described (Paatero 1997). A receptor model mass balance equation is written so that the measured concentration of the *i*th element in the measured mass is the sum of the contribution from each source given by the equation:

$$x_{ij} = \sum_{k=1}^n c_{ik}s_{kj} + e_{ij} \quad (2.9)$$

where *n* is the number of distinguishable sources, *x_{ij}* is the chemical concentration of the *j*th species in the *i*th sample, *c_{ik}* is the particulate mass concentration contributed by the *k*th source from the *i*th sample (g/m³), *s_{kj}* is the *j*th species mass fraction in g of species

per g total PM_{2.5} in the *k*th source, and *e*_{*ij*} accounts for remaining mass associated with the *i*th species in the *j*th sample.

The factor analysis matrix equation is given by:

$$X = G \times F + E \quad (2.10)$$

where *X* is the data matrix, *E* is the matrix of residuals, *G* is the source contribution matrix and *F* is the source profile matrix. PMF2 uses an algorithm (Paatero 1997) in which the *G* and *F* matrixes are simultaneously varied. An “object function” is employed

$$Q(E) = \sum_{i=1}^p \sum_{j=1}^q \left[\frac{e_{ij}}{u_{ij}} \right] \quad (2.11)$$

where the estimate of the uncertainty in the *j*th component measured in the *i*th species is given by *u*_{*ij*}. PMF provides a solution in which *Q*(*E*) is minimized with respect to the *G* and *F* matrixes forcing all values to be non-negative. Furthermore, the results are constrained so that source contributions cannot be negative for any species.

Semi-continuous monitoring data have been shown to greatly improve the power of receptor models to determine sources as shown in Chapter 3. Chapters 5 and 7 illustrate the use of PMF2 to deduce source contributions from the sampling campaigns conducted in Rubidoux, CA during July 2003 and Fresno, CA during December 2003, respectively. Chapters 5 and 7 discuss the application of PMF2 to semi-continuous 1-h averaged data, the PMF2 results obtained, and the interpretation of the resulting source profiles and contributions.

2.5. Data Analysis

The statistical treatment of data for all of the studies conducted was performed using Quattro Pro Version 9. Both a zero intercept slope regression and a slope calculated regression was performed. Average values (\bar{C}) of each replicate set ($j=1,2$) were calculated as:

$$\bar{C}_j = \frac{1}{N} \sum_{i=1}^N C_{ji} \quad (2.12)$$

where N is the total number of replicate pairs. The bias corrected precision (standard deviation) was calculated as:

$$\sigma = \sqrt{\frac{1}{2N} \sum_{i=1}^N [(C_{1,i} - C_{2,i})^2 - (\bar{C}_1 - \bar{C}_2)^2]} \quad (2.13)$$

where $C_{1,i}$ and $C_{2,i}$ are the concentrations for each compared pair and \bar{C}_1 and \bar{C}_2 are the average concentrations for each data set. The precision percent uncertainty (relative standard deviation %) was calculated as:

$$\sigma\% = \frac{\sigma}{(\bar{C}_1 + \bar{C}_2) / 2} \times 100 \quad (2.14)$$

2.6. References

- Al-Horr, R., Samantha, G., and Dasgupta, P.K. (2003). A Continuous Analyzer for Soluble Anionic Constituents and Ammonium in Atmospheric Particulate Matter. *Aerosol. Sci. Technol.* 37: 5711-5720.
- Agarwal, J.K. and G. J. Sem (1978) "Generating Submicron Monodisperse Aerosols for Instrument Calibration" *TSI Quarterly*, Vol. 4, No. 2 pp. 3-8
- Agarwal, J.K., G.J. Sem and R.J. Remairz (1985) "Filter Testing With a Continuous-Flow, Single-Particle-Counting Condensation Nucleus Counter" *TSI Quarterly*, Vol. 11, No. 1, pp. 3-12
- Birch, M. E.; Cary, R. A. (1996). Elemental carbon-based method for occupational monitoring of particulate diesel exhaust: methodology and exposure issues. *Analyst* 121: 1183-1190.
- Boring, C.B., Al-Horr, R., Genfa, Z., Dasgupta, P.K., Martin M.W., and Smith, W.F. (2002). Field Measurements of Acid Gases and Soluble Anions in Atmospheric Particulate Matter using a Parallel Plate Wet Denuder and Alternating Filter-Based Automated Analysis System. *Anal. Chem.* 74: 1256-1268.
- Chung, S. H., and Seinfeld, J. H., (2002). Global Distribution and Climate Forcing of Carbonaceous Aerosols. *J. Geophysical Research.* 107: 4407.
- Cui, W., Eatough, D.E., Eatough, N.L. (1998) Fine particulate organic material in the Los Angeles Basin - I: assesment of the high-volume Brigham Young Univeristy organic sampling system, BIG BOSS. *J. Air Waste Manage. Assoc.* 48: 1024-1037.
- Dasgupta, P.K., Poruthoor, S.K. (2002). *Comprehensive Analytical Chemistry*, 37th ed., J. Pawliszyn, ed., Elsevier Science B.V., Amsterdam, 2002; pp 161-276.
- Ding, Y., Pang, Y., Eatough, D.J., Eatough, N.L., and Tanner, R.L. (2002a). High-Volume Diffusion Denuder Samplers for the Routine Monitoring of Fine Particulate Matter: I. Design and Optimization of the PC-BOSS. *Aerosol Sci. Technol.* 36: 369-382.
- Ding, Y., Pang, Y., Eatough, D.J., Eatough, N.L., and Tanner, R.L. (2002b). High-Volume Diffusion Denuder Samplers for the Routine Monitoring of Fine Particulate Matter: II. Field Evaluation of the PC-BOSS. *Aerosol Sci. Technol.* 36: 383-396.

Eatough, D.J., Obeidi, F., Pang, Y., Ding, Y., Eatough, N.L., and Wilson W.E., (1999). Integrated and real-time diffusion denuder samplers for PM_{2.5} based on BOSS, PC and TEOM technology. *Atmos. Environ.* 33: 2835-2844.

Eatough, D.J., Eatough, N.L., Obeidi, F., Pang, Y., Modey, W., and Long, R. (2001) Continuous determination of PM_{2.5} mass, Including Semi-Volatile Species. *Aerosol Sci. Technol.* 34: 1-8.

Ellis, E.C. and Novakov, T., (1982). Application of thermal analysis to the characterization of organic aerosol particles. *Sci.of the Total Environ.*, 23: 227-238.

Finlayson-Pitts B.J, J. N. Pitts, (1999) *Chemistry of the Upper and Lower Atmosphere* Academic Press, San Diego, CA.

Grover, B .D., Kleinman, M. A., Eatough, N. L., Eatough, D. J., Hopke, P. K., Long, R. W., Wilson, W. E., Meyer, M. B., Ambbs, J. L. (2005). Measurement of Total PM_{2.5} Mass (Nonvolatile plus Semi-Volatile) with the FDMS TEOM Monitor. *J. Geophysical Research*, 110, D07S03.

Grover, B. D, Carter, C. B. Kleinman, M. A., Richards, J. S., Eatough, N. L. and Eatough, D. J. Monitoring and Source Apportionment of Fine Particulate Matter at Lindon, Utah. *Aerosol Sci. Technol.* In Press.

Hansen, A.D.A (2002). *The Aethalometer Operating Manual*, http://www.mageesci.com/Aethalometer_book_2002.06.5.pdf, accessed September 16, 2002.

Henry, R.C., and Norris, G.A. (2001). EPA UNMIX 2.3 user guide.

Keady, P. B., Quant, F. R., Sem, G. J. (1984). Automated differential mobility particle sizer. Proceedings for the 1st Int'l Aerosol Conference, Minneapolis, MN pp. 71-74.

Kim, E, Hopke, P. K., Edgerton, E. S. (2003). Source Identification of Atlanta Aerosol by Positive Matrix Factorization. *J. of Air & Waste Manage. Assoc.* 53: 731-739.

Knutson, E. O., Whitby, K. T. (1975). Aersol classification by electric mobility. Apparatus theory and applications. *J Aerosol Sci.* 6: 443.

Li, J.; Dasgupta, P.K. (2000). Measurement of Atmospheric Hydrogen Peroxide and Hydroxymethyl Hydroperoxide with a Diffusion Scrubber and Light Emitting Diode-Liquid Core Waveguide-Based Fluorometry. *Anal. Chem.* 72: 5338-5347.

Lewis, C. W., Norris, G. A., Conner, T. L., and Henry, R. C. (2003). Source Apportionment of Phoenix PM_{2.5} Aerosol with the Unmix Receptor Model. *J. Air & Waste Manage. Assoc.* 53: 325-338.

Lewtas, J., Booth, D., Pang, Y., Reimer, S., Eatough, D.J., and Gundel, L. (2001). Comparison of sampling methods for semi-volatile organic carbon (SVOC) associated with PM_{2.5}. *Aerosol Sci. Technol.* 34: 9-22.

Long, R.W., Smith, R., Smith, S., Eatough, N.L., Mangelson and Eatough, D.J. (2002) Sources of Fine Particulate Material along the Wasatch Front, *Energy and Fuels*. 16: 282-293.

Long, R. W., Eatough, N. L., Mangelson, N. F., Thompson, W., Fiet, K., Smith, S., Smith, R., and Eatough, D. J., (2003). The Measurement of PM_{2.5}, Including Semi-Volatile Components, in the EMPACT Program: Results from the Salt Lake City Study and Implications for Public Awareness, Health Effects, and Control Strategies, *Atmos. Environ.* 37: 4407-4417.

Meyer, M.B., Patashnick, H., and Ambs, J.L., Ongoing development of a continuous reference standard particulate matter mass monitor for ambient air, paper presented at the Symposium on Air Quality Measurement Methods and Technology, San Francisco, CA, November, 2002.

Mignacca, D., Stubbs, K. (1999) Effects of Equilibration temperature on PM₁₀ Concentrations from the TEOM Method in the Lower Fraser Valley. *J. of Air & Waste Manage. Assoc.* 49: 1250-1254.

Modey, W. K., Pang, Y., Eatough, N. L., and Eatough, D. J., (2001). Fine Particulate (PM_{2.5}) Composition in Atlanta, USA: Assessment of the Particle Concentrator Brigham Young University Organic Sampling System, PC-BOSS, During the EPA Supersite Study, *Atmos. Environ.* 35: 6493-6502.

Noble, M.A., Vanderpool, R.W., Peters, T.M., McElroy, F.F., Gemmill, D.B., Wiener, R.W. (2001) Federal reference and equivalent methods for measuring fine particulate matter. *Aerosol Sci. Technol.* 34: 457-464.

Obeidi, F., Eatough, D.J. (2002). Continuous Measurement of semivolatile fine particulate mass in Provo, UT. *Aerosol Sci. Technol.* 36: 191-203.

Obeidi, F., Eatough, N.L., Eatough, D.J. (2002). Use of the RAMS to measure semivolatile particulate matter at Riverside and Bakersfield, California. *Aerosol Sci. Technol.* 36: 204-216.

Pang, Y., Eatough, N.L., Wilson, J., Eatough, D.E., (2002a). Effect of semivolatile material on PM_{2.5} measurement by the PM_{2.5} federal reference method sampler at Bakersfield, California. *Aerosol Sci. Technol.* 36: 289-299.

Paatero, P. (1997) Least squares formulation of robust, non-negative factor analysis. *Chemomet. Intell. Lab. Syst.* 37: 13-35.

U.S. Environmental Protection Agency. *Quality Assurance Handbook for Air Pollution Measurement Systems, Volume II: Ambient Air Specific Methods*, EPA-600/R-94-038b, April 1994.

Rupprecht & Patashnick, (1996). TEOM Series 1400a Ambient Particulate Monitor, Operating Manual. R&P Part Number 42-003347.

Rupprecht & Patashnick, (2003). Series 8500 FDMS Filter Dynamics Measurement System, Operating Manual. R&P Part Number 42-008428.

Sioutas, C., Koutrakis, P., and Burton, R.M. (1994). Development and Evaluation of a Low Cutpoint Virtual Impactor. *Aerosol Sci. Technol.* 21: 223-235.

Stolzenburg, M.R., and Hering, S.V., (2000). Method for the automated measurement of fine particulate nitrate in the atmosphere. *Environ. Sci. Technol.*, 34: 907-914.

Tang, H., Lewis, E. A., Eatough, D. J., Burton, R. M., and Farber, R. J. (1994). Determination of the particle size distribution and chemical composition of semi-volatile organic compounds in atmospheric fine particles. *Atmos. Environ.* 28: 939-947.

Turpin, B.J., and Lim, H.J. (2001). Species Contributions to PM_{2.5} Mass Concentrations: Revisiting Common Assumptions for Estimating Organic Mass. *Aerosol Sci. Technol.* 35: 602-610.

Willis, R. D., Ellenson, W.D., Conner, T.L. (2001). Monitoring and source apportionment of particulate matter near a large phosphorous production facility. *J. of Air & Waste Manage. Assoc.* 51: 1142-1166.

Yi, S.-M., Ambs, J.L., Patashnick, H., Rupprecht, G., Hopke, P.K., Evaluation of a prototype electrostatic precipitator (ESP) for a differential TEOM system, *Aerosol Science and Technology*, submitted, 2004.

Zheng, L., Hopke, P. K., Husain, L., Qureshi, S., Dutkiewicz, V. A., Schwab, J. J., Drewnick, F., Demerjian, K. L. (2004) Sources of fine particle composition in New York City. *Atmos. Environ.* 38: 6521-6529

Chapter 3. Monitoring and Source Apportionment of Fine Particulate Matter at Lindon, Utah

3.1. Overview

Human health endpoints associated with exposure to airborne particulate matter (PM) include increased mortality and morbidity from respiratory and cardiopulmonary disease (Pope, 2000; Schwartz *et al.*, 1996; U.S. EPA, 1996). Identification of the component(s) of fine particles responsible for the epidemiologically identified health effects would significantly aid implementation of the new PM_{2.5} standard. New research is focusing on the improved characterization of urban PM_{2.5}. The measurement of the time-relevant exposure of a population to total PM_{2.5} mass and components, including particulate semi-volatile species, will most likely assist in the identification of PM_{2.5} etiological agents, which result in mortality and morbidity effects associated with exposure to fine particles. This will allow for the development of appropriate attainment strategies, the collection of better exposure data, and an improvement in risk assessment studies and analyses. The use of both integrated and continuous samplers to meet this objective is described here. The application of these samplers to the study of atmospheric chemistry at the Lindon, UT sampling site has shown that a substantial fraction of the fine particulate matter in these environments is semi-volatile organic and nitrate material (SVM). Neither an EPA PM_{2.5} FRM or similar single-filter sampler, or a TEOM monitor can accurately determine SVM. Furthermore, the Lindon, UT and other EMPACT studies have shown that the majority of the semi-volatile organic material (SVOM) is secondary (Eatough *et al.*, 2003). The comparison of continuous samplers which measure both the mass and composition of fine particulate material has not been

previously reported. Such a study was conducted at Lindon, UT in August 2002. Results from this study are reported here.

3.2. Experimental

3.2.1. Sampling Location

The sampling site was located at the Lindon Elementary School, adjacent to a State of Utah air quality sampling site. The location of the sampling site relative to the Salt Lake urban area STAR and EMPACT BYU sites (Long *et al.*, 2003; 2002) is shown in Figure 3.1. The site is located in the Provo - Orem urban complex 65 km south of Salt Lake City and has been the location of previous epidemiological studies focused on the effect of emissions from the steel mill located at Vineyard (Pope, 2000). However, the steel mill was not in operation during the time of this study. As a result, the sampling site is expected to be impacted predominately by emissions from mobile sources (both gas and diesel) and, during the winter, wood smoke emissions from residential wood burning stoves. There are no significant point sources of pollution which are expected to impact the site.

3.2.2. Sampling Methods

The various samplers used to monitor fine particulate material included samplers to determine particulate mass and samplers to determine specific fine particulate components. Samplers used in this study are given in the following sections and were outlined in detail in Chapter 2.

R&P TEOM Monitor. Using an R&P TEOM monitor operating under normal conditions, 1-h averaged $PM_{2.5}$ mass concentrations were determined at the Lindon, UT site (Patashnick and Rupprecht, 1991). As stated previously, semi-volatile PM will

Figure 3.1. Location of the Lindon, Utah sampling site.



evaporate at the standard operating temperature of the instrument, 50° C, which is required to remove particle-bound water (Mignacca and Stubbs, 1999). At the TEOM filter temperature, this technique measures only non-volatile PM.

RAMS. The configuration and operation of the RAMS, as used in the Lindon study, have been described previously (Long *et al.*, 2003; Eatough *et al.*, 2001) and is described extensively in Chapter 2. For this study, RAMS data were averaged over 1-h periods for comparison with 1-h averaged TEOM data.

Fine Particulate Ammonium, Sulfate and Nitrate. Instrumentation for the measurement of atmospheric inorganic species was outlined in detail in Chapter 2. The instrument used in this study was the TTU soluble ion monitor. Fine particulate nitrate, sulfate and ammonium concentrations were averaged over 1-h periods for comparison with other semi-continuous data.

Fine Particulate Carbon. The Series 5400 ambient carbon particulate monitor from Rupprecht & Patashnick was used to characterize the carbon content of fine particles on a continuous basis. During the analysis phase, the collected sample is first heated to 375 °C to determine organic carbon (OC) and then to 750 °C to determine total carbon (TC) concentrations. Elemental carbon (EC) is determined by the difference between the TC and the OC measurements. It was assumed that fine particulate organic material (OM) was 62% carbon, typical of an aged urban aerosol (Turpin and Lim, 2001). Because of operational problems, carbon data were only obtained every other hour.

Anderson Aethalometer. An Anderson Instruments (Model RTAA-900) Aethalometer was used for the determination of aerosol EC. One-h average EC

concentrations were obtained and compared with the 1-h averaged TEOM and RAMS data. Anderson Aethalometer UV absorption measurements are believed to be a good marker of fresh diesel emissions (Hansen, 2002) and therefore, 1-h averaged UV absorption data were also obtained throughout the study.

Gas Phase Monitors. Hourly-averaged concentrations of carbon monoxide (CO) were measured using an API Model 300 analyzer. In addition, a Thermo Environmental Instruments Model 42 NO_x analyzer was used to monitor for nitrogen oxides (NO_x) and nitrogen dioxide (NO₂). These two instruments were provided by the State of Utah Air Quality Division. Ozone (O₃) was measured using a UV photometric dual beam instrument (Dasibi 1003 AH). Hydrogen peroxide (H₂O₂) concentrations were determined using a diffusion scrubber based fluorometric instrument (Li and Dasgupta, 2000).

Integrated PC-BOSS Determination of PM_{2.5} Composition and Mass. The PC-BOSS was used to determine fine particulate mass, sulfate, carbonaceous material (elemental and organic), nitrate, semi-volatile organic material, and semi-volatile nitrate. A combination of 3-, 6- and 24-h PC-BOSS samples were collected during the study. PC-BOSS filters were analyzed by TPV and IC as outlined in Chapter 2.

3.3. Results and Discussion

3.3.1. Data Trends and Comparisons

The TEOM monitor data obtained during the study are shown in Figure 3.2. As indicated, concentrations were generally low throughout the study, with an increase during the August 16 - August 23 time period. This time period was chosen for more detailed analysis in this paper and for source apportionment using the EPA UNMIX

Figure 3.2. Hourly-averaged TEOM monitor data obtain at the Lindon sampling site in August 2002. The data shown between the dotted lines were used for interpretation of the combined continuous sampler data set in this chapter.

Hourly Averaged Data at Lindon, UT

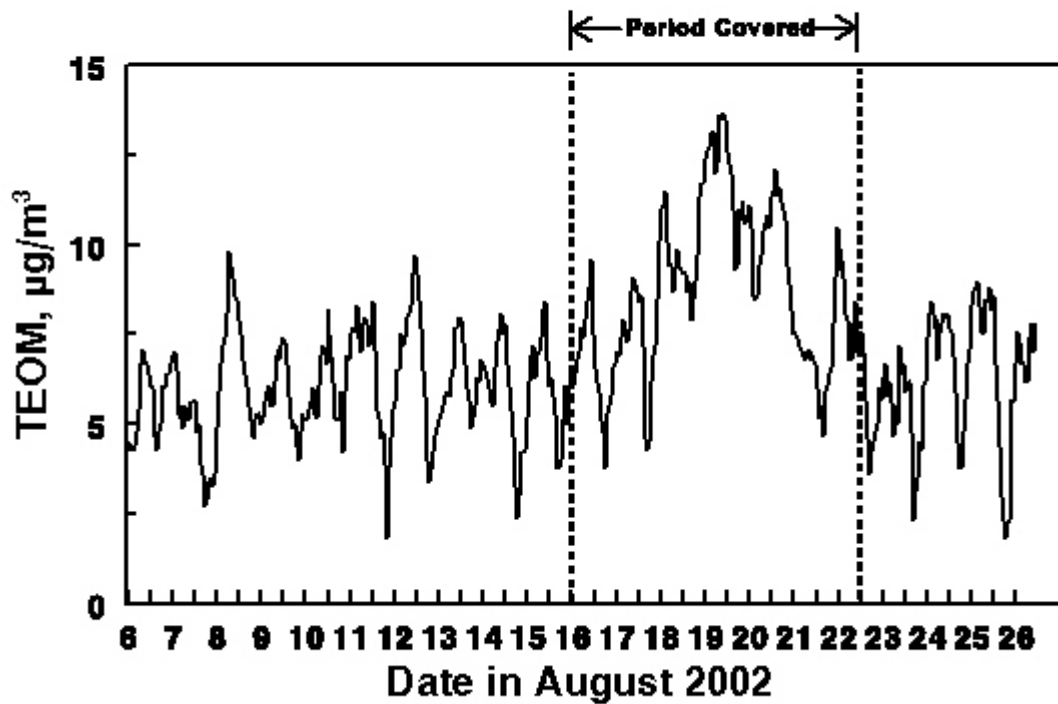

program. However, even though low, the TEOM data show a clear diurnal pattern with maxima generally being seen during each mid-day period.

A combination of 3-, 6-, and 24-h PC-BOSS samples were obtained throughout the sampling time period. The average composition of $PM_{2.5}$ as determined by the PC-BOSS over the whole time period (August 1- August 26) is shown in Figure 3.3. The main component of $PM_{2.5}$ as determined with the PC-BOSS over the sampling period was non-volatile organic material (NVOM), assumed to be 62% carbon (Turpin and Lim, 2001) which is consistent with previous studies performed at the Lindon sampling site (Long *et al.*, 2003) For the time period of interest, daily averaged, PC-BOSS detailed particle composition data is shown in Figure 3.4. Sulfate and nitrate are expected to be present as the ammonium salts due to excess ammonia at the Lindon sampling site.

The 1-h average RAMS, TEOM monitor, and inorganic composition (the sum of ammonium sulfate and ammonium nitrate measured by the soluble ion particulate sampler) concentrations are given in Figure 3.5A. Hourly-averaged concentrations of EC, ammonium sulfate, and ammonium nitrate are shown in Figure 3.5B. The 1-h average concentrations of gas phase compounds, related to both primary emissions and the formation of secondary aerosol species, are displayed in Figures 3.5C and 3.5D and include NO_2 , NO_x , O_3 and H_2O_2 .

Regression statistics for sulfate and nitrate comparisons as determined by the PC-BOSS and the ion chromatographic soluble ion particulate sampler are given in Table 3.1 and the data are compared in Figures 3.6 and 3.7, respectively. One statistical outlier was observed in the nitrate comparison. This was a sample with essentially zero concentration for the PC-BOSS sample, but not for the IC sample, and is shown in Figure

Figure 3.3. Average fine particulate composition over the study period (August 1 - August 26, 2002). Am, SV and NV represent ammonium, semi-volatile and nonvolatile respectively.

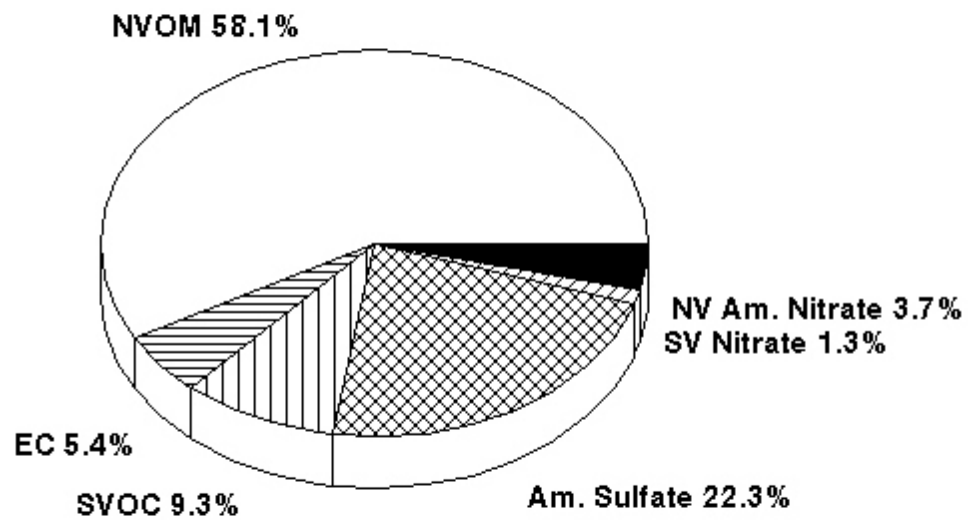

Figure 3.4. Daily averaged fine particle composition during the time period of interest (August 16 - August 23, 2002). Am, SV and NV represent ammonium, semi-volatile and nonvolatile respectively.

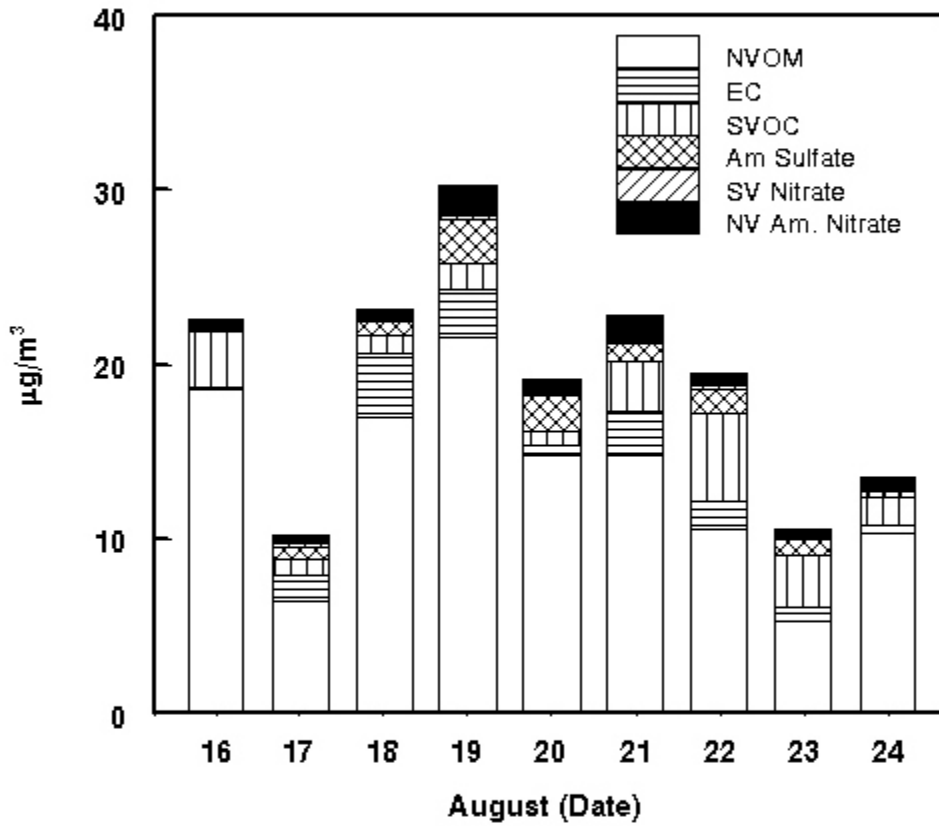

Figure 3.5. Hourly-averaged concentrations of TEOM monitor mass, RAMS mass, PM_{2.5} inorganic material, ammonium sulfate, ammonium nitrate, elemental carbon and gas phase compounds measured with the various continuous monitors.

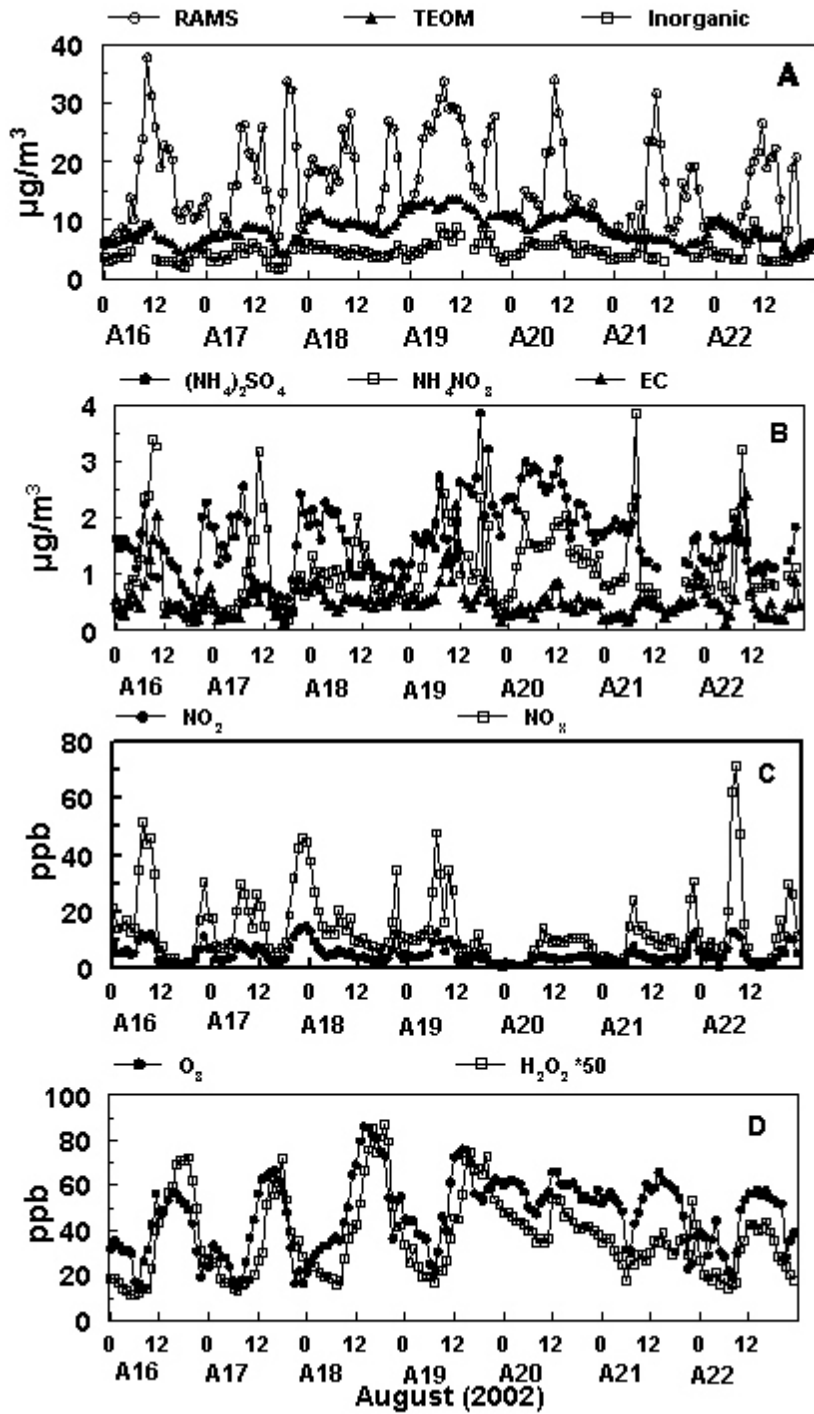

Table 3.1. Regression Statistics for Sulfate and Nitrate Comparison.

X vs Y	n	R ²	Slope ^a	Intercept mg/m ³	X Average mg/m ³	Y Average mg/m ³	X-Y Bias mg/m ³		
Real-Time Sulfate vs. PC-BOSS Sulfate	16	0.76 0.76	0.93±0.02 0.96±0.07	0 -0.02	1.25	1.16	0.09	0.20	16.5
Real-Time Nitrate vs. PC-BOSS Nitrate ^b	15	0.07 0.14	0.88±0.06 0.53±0.16	0 0.28	0.72	0.66	0.06	0.27	38.6
PC-BOSS Constructed Mass vs. RAMS	19	0.01 0.25	0.95±0.03 0.49±0.09	0 9.09	17.78	17.79	-0.02	4.16	23.4

^aSlopes are given for (1) zero intercept and (2) calculated intercept

^bData does not include one statistical outlier that could not be explained.

Figure 3.6. Comparison of PC-BOSS and semi-continuous sulfate.

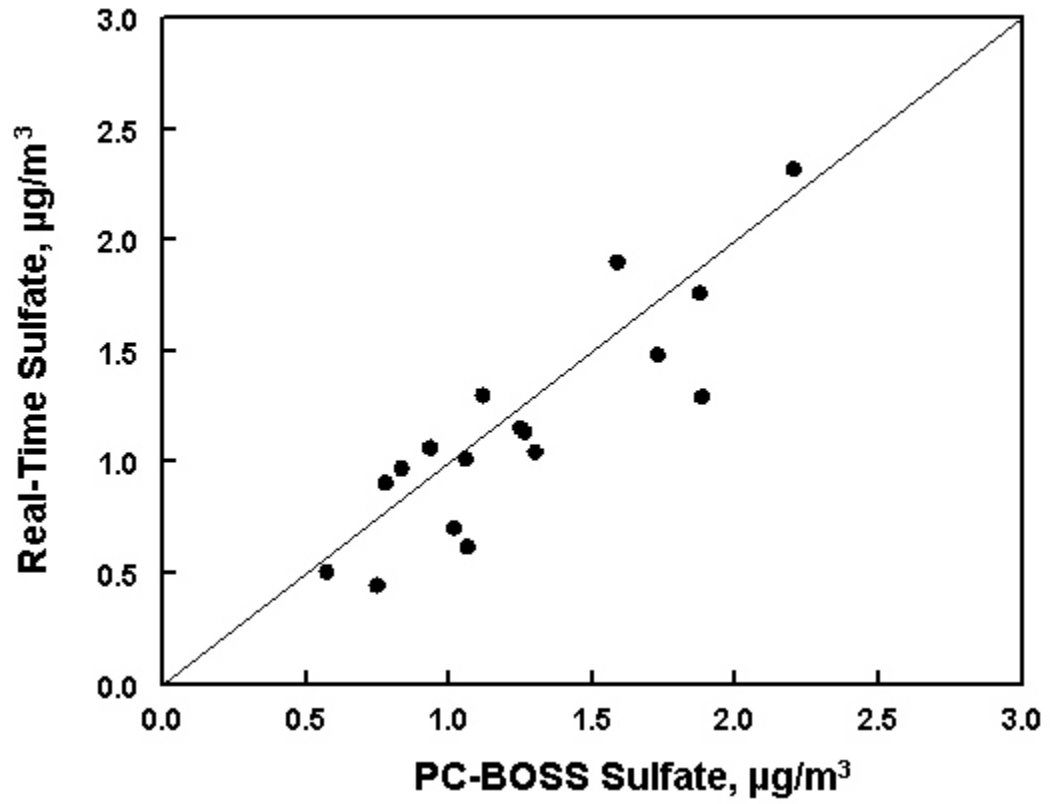
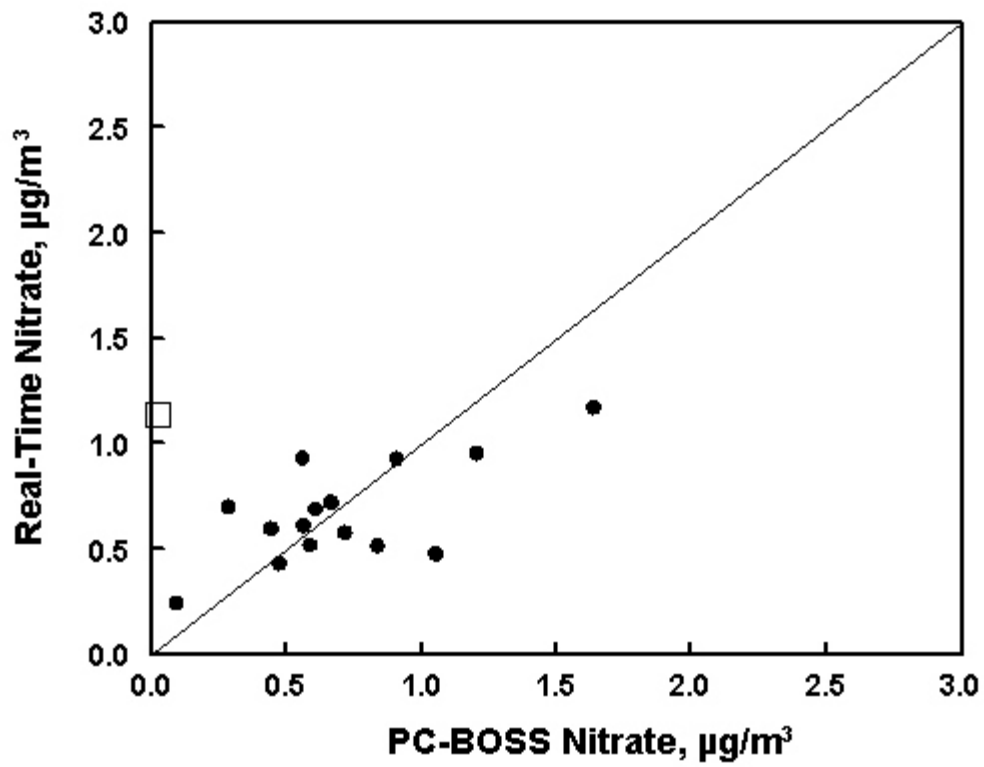

Figure 3.7. Comparison of PC-BOSS and semi-continuous nitrate.



3.7 as the open square data point. Good agreement was observed between concentrations of sulfate. The poorer agreement for nitrate as compared to sulfate can be attributed to the lower concentrations present during the study, the σ values being comparable, and the average concentration being only 2σ as shown in Table 3.1.

The summation of all chemical components of an aerosol as determined by the PC-BOSS (including the sum of nonvolatile organic material, semi-volatile organic material, ammonium sulfate, ammonium nitrate, lost ammonium nitrate, and EC) results in total $PM_{2.5}$ concentrations represented as PC-BOSS constructed mass. Poor precision was observed between the concentration of total particulate matter measured by the RAMS and the integrated constructed mass of the PC-BOSS. The zero-intercept line had a slope of 0.95 ± 0.03 but an R^2 of only 0.25. As indicated by the data in Figure 3.8, the results scatter around the slope=1 line, but with a σ value of $\pm 4.2 \mu\text{g}/\text{m}^3$. This sigma value is comparable to that previously seen between RAMS and PC-BOSS integrated mass (Eatough *et al.*, 2003; Long *et al.*, 2003) but average concentrations in these previous studies were about a factor of four higher. During this study period, the σ value did not improve at lower concentrations. While probably accurate, the RAMS data were considered too noisy to be useful in the following UNMIX analysis. However, the TEOM data should be of sufficient quality to be used in UNMIX source apportionment analysis and are, therefore, used in the subsequent analyses. It should be recognized that semi-volatile $PM_{2.5}$ is not included in this metric. Both the ammonium nitrate and SVOM (not measured by the TEOM) are dominantly secondary. Since the sulfate is expected to also be mostly secondary, TEOM mass minus sulfate concentrations were used as a measure of “primary” $PM_{2.5}$ mass. FRM $PM_{2.5}$ mass was measured by the State

Figure 3.8. Comparison of RAMS and PC-BOSS constructed $PM_{2.5}$.

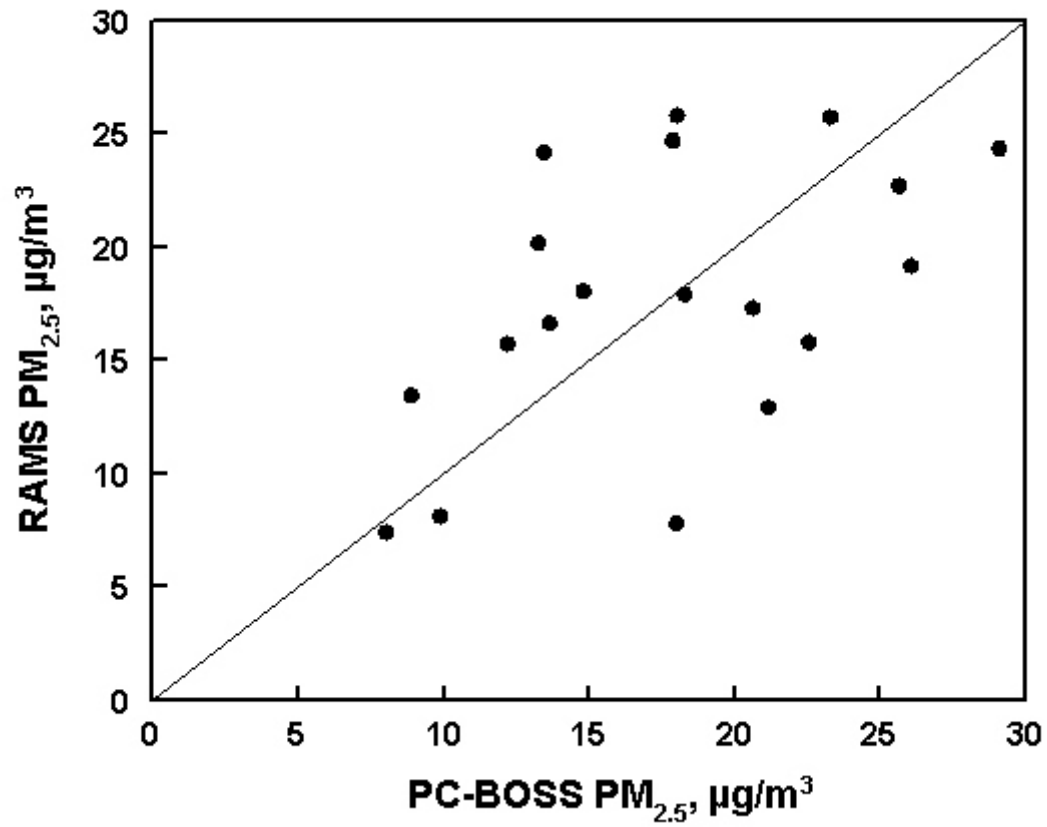

of Utah at the site, but only on an every six day basis. Thus, there were not sufficient data for a meaningful comparison.

3.4. Source Apportionment Analysis

3.4.1. Approach

It has previously been shown that the combination of $PM_{2.5}$ mass and composition data, coupled with appropriate gaseous data, can be used to identify the major sources of fine particulate material along the Wasatch Front (Eatough *et al.*, 2003; Long *et al.*, 2003) using the EPA UNMIX program (Henry and Norris, 2001). UNMIX is a factor analysis technique that generates only source contributions and profiles that are nonnegative or “real,” a problem which plagues traditional factor analysis techniques. Two algorithms are used in UNMIX to define source “edges” in the input data which are related to contributions of each of the sources defined (Lewis *et al.*, 2003). Several ambient species can be used to predict source contributions. Secondary aerosol species, such as O_3 and H_2O_2 , can be related to secondary source profiles. EC and UV absorption, obtained from the Anderson Aethalometer, can be used as an indicator of primary diesel emissions. Nitrogen oxides have been used as an indicator of primary automobile emissions. Also, primary wood smoke emissions can be identified using NO_x as a marker. The percent contribution of each of the sources to $PM_{2.5}$ can be determined by calculating the average source concentration over the time period divided by the total of the average source concentrations of all the source species identified.

The combination of particulate mass and composition data, as well as gas phase pollutant data, resulted in the identification of both primary and secondary emission source profiles using UNMIX. Sources of primary $PM_{2.5}$ mass (defined as the TEOM

monitor mass minus the sulfate), and primary and secondary sulfate and nitrate were identified. SVM could also be calculated as the RAMS mass minus the TEOM monitor mass, but because of the uncertainty in the RAMS data, the difference was considered too uncertain to be used in an UNMIX analysis. However, the SVM concentrations calculated from the TEOM monitor and RAMS data are higher than those inferred from the PC-BOSS data (Figure 3.2), probably because much more SVM is lost from the heated TEOM monitor filter than from the PC-BOSS filters.

For the TEOM monitor mass, UNMIX yielded a six component four factor solution (Table 3.2) with an $R^2 \geq 0.94$, a minimum signal-to-noise of 2.79 and a strength of 9.00. This is a robust result based on the obtained fitting parameters. Two primary emissions sources, attributed to primary diesel emissions and primary auto emissions based on the profiles and time patterns of the sources, were identified. Two secondary source profiles were also identified which can be attributed to daytime and nighttime secondary formation processes, based on the low contributions of NO_x and EC in these sources, and the observed source profiles. Sulfate and nitrate were not included as fitting parameters for the primary $\text{PM}_{2.5}$ analysis as they were not included in the corrected TEOM data. O_3 was attempted as a fitting parameter, but did not prove useful. It is interesting to note that while ammonium sulfate and ammonium nitrate were not included in the $\text{PM}_{2.5}$ fitted by UNMIX, most of the TEOM $\text{PM}_{2.5}$ appeared to be secondary in nature (Table 3.2). Presumably, this represents mostly secondary organic material.

A linear regression comparison of the sulfate adjusted TEOM mass (x axis) and the sum of the four source contributions (y axis) gave ($N = 160$, $R^2 = 0.80$) a slope of 0.81 ± 0.3 and an intercept of $-0.2 \pm 0.9 \mu\text{g}/\text{m}^3$. The UNMIX analysis accounts for an

Table 3.2. UNMIX Source Composition of Sources Normalized for Primary PM_{2.5} TEOM Monitor Mass^a.

Species	Primary Diesel Normalized for PM _{2.5}	Primary Auto Normalized for PM _{2.5}	Secondary (Daytime) Normalized for PM _{2.5}	Secondary (Nighttime) Normalized for PM _{2.5}
EC	0.30, ng EC/ g PM _{2.5}	0.10, ng EC/ g PM _{2.5}	0.07, ng EC/ g PM _{2.5}	0.10, ng EC/ g PM _{2.5}
UV	0.30, UV Units/ g PM _{2.5}	0.12, UV Units/ g PM _{2.5}	0.10, UV Units/ g PM _{2.5}	0.16, UV Units/ g PM _{2.5}
NO ₂	0.18, ppb NO ₂ / g PM _{2.5}	3.66, ppb NO ₂ / g PM _{2.5}	0.40, ppb NO ₂ / g PM _{2.5}	0.76, ppb NO ₂ / g PM _{2.5}
NO _x	0.43, ppb NO _x / g PM _{2.5}	14.85, ppb NO _x / g PM _{2.5}	-0.02, ppb NO _x / g PM _{2.5}	-0.81, ppb NO _x / g PM _{2.5}
H ₂ O ₂	-0.01, ppb H ₂ O ₂ / g PM _{2.5}	0.05, ppb H ₂ O ₂ / g PM _{2.5}	0.49, ppb H ₂ O ₂ / g PM _{2.5}	0.19, ppb H ₂ O ₂ / g PM _{2.5}
Average PM _{2.5} Mass	0.42 g/m ³	0.62 g/m ³	1.39 g/m ³	4.45 g/m ³

^aTEOM PM_{2.5} minus sulfate

average of $6.8 \mu\text{g}/\text{m}^3$ of the average total of $8.6 \mu\text{g}/\text{m}^3$, with an average of $1.8 \mu\text{g}/\text{m}^3$ unaccounted for. As shown in the R^2 value for the fit, the fraction of the “primary” TEOM $\text{PM}_{2.5}$ mass not accounted for is fairly constant. This presumably reflects background $\text{PM}_{2.5}$ not associated with any of the UNMIX fitting parameters. For example, crustal material would be included in the unaccounted for mass.

For the sulfate fraction of the aerosol, all the parameters used in the primary TEOM $\text{PM}_{2.5}$ analysis plus sulfate, nitrate, chloride and ozone were used. UNMIX identified a nine component four factor solution with an $R^2 \geq 0.37$, a minimum signal-to-noise ratio of 2.22 and a strength of 1.07. Primary emission sources can be attributed to primary diesel emissions and primary auto emissions based on the profiles (presence of EC and/or NO_x) and diurnal patterns. Apparent secondary sources can be categorized into daytime and nighttime formation processes as was the case for TEOM $\text{PM}_{2.5}$ (see Table 3.3). The presence of some O_3 and H_2O_2 in the primary sources is probably an artifact of the co-presence of these species. However, the amount of O_3 and H_2O_2 associated with the primary sources is small compared to that associated with the secondary sources.

For the nitrate fraction, UNMIX yielded a nine component four factor solution (Table 3.4) with an $R^2 \geq 0.37$, a minimum signal-to-noise of 2.14 and a strength of 1.08. The results paralleled those for sulfate. Two of these sources were attributed to primary diesel emissions and primary auto emissions, respectively, and two to secondary emission source profiles consistent with daytime and nighttime chemistry, based on the same chemical species association and diurnal pattern considerations.

3.4.2. UNMIX Results Robustness

As outlined above, because of the assumptions made in the calculation of primary TEOM PM_{2.5}, different parameters were used in the PM_{2.5}, sulfate and nitrate apportionment calculations. If the results obtained in the various analyses are meaningful, however, similar contributions to various key profile species should be seen for each of the four sources in the various analyses. This can be tested using the data given in Tables 3.2 - 3.4. The amount of NO_x associated with each source is calculated by UNMIX apportioned mass times the appropriate UNMIX ratio in the obtained profile. For example, for the primary TEOM PM_{2.5} results (Table 3.2), the amount of NO_x associated with the primary auto source is $0.62 \mu\text{g PM}_{2.5}/\text{m}^3 \cdot 14.85 \text{ ppb NO}_x/\mu\text{g PM}/\text{m}^3 = 9.2 \text{ ppb NO}_x$. Similar calculations for the various values given in Tables 3.2 - 3.4 gives the result that about 90% of the NO_x for each of the calculations is associated with the primary auto source, with about 10% associated with the primary diesel source and less than 2% associated with any of the secondary sources. Therefore, there is consistency among the various UNMIX analysis results for the primary emission, NO_x, even though the PM_{2.5} calculation uses different assumptions than the other two UNMIX analyses. Likewise H₂O₂, a secondary species, is better than 80% associated with the secondary sources for each analysis. The division of H₂O₂ between the secondary sources is different for PM_{2.5} (organic material), sulfate, and nitrate. These differences would be expected to reflect the varying importance of H₂O₂ in the formation of secondary organic material, sulfate, or nitrate associated with the daytime or nighttime conversion processes.

Table 3.3. UNMIX Source Compositions of Sources Normalized for Ammonium Sulfate.

Species	Primary Diesel Normalized for Primary Sulfate ^a	Primary Auto Normalized for Primary Sulfate ^a	Secondary (Daytime) Normalized for Primary Sulfate ^a	Secondary (Nighttime) Normalized for Primary Sulfate ^a
EC	9.22, ng EC/ g Sulfate	0.25, ng EC/ g Sulfate	0.21, ng EC/ g Sulfate	0.05, ng EC/ g Sulfate
UV	9.38, UV Units/ g Sulfate	0.37, UV Units/ g Sulfate	0.33, UV Units/ g Sulfate	0.05, UV Units/ g Sulfate
NO ₂	9.97, ppb NO ₂ / g Sulfate	9.97, ppb NO ₂ / g Sulfate	1.56, ppb NO ₂ / g Sulfate	0.73, ppb NO ₂ / g Sulfate
NO _x	30.48, ppb NO _x / g Sulfate	38.19, ppb NO _x / g Sulfate	1.11, ppb NO _x / g Sulfate	0.06, ppb NO _x / g Sulfate
O ₃	102.02, ppb O ₃ / g Sulfate	9.98, ppb O ₃ / g Sulfate	50.88, ppb O ₃ / g Sulfate	19.18, ppb O ₃ / g Sulfate
H ₂ O ₂	0.09, ppb H ₂ O ₂ / g Sulfate	0.31, ppb H ₂ O ₂ / g Sulfate	1.01, ppb H ₂ O ₂ / g Sulfate	0.22, ppb H ₂ O ₂ / g Sulfate
Nitrate	8.52, g Nitrate/ g Sulfate	0.37, g Nitrate/ g Sulfate	0.01, g Nitrate/ g Sulfate	0.76, g Nitrate/ g Sulfate
Chloride	-0.12, g Chloride/ g Sulfate	0.36, g Chloride/ g Sulfate	0.14, g Chloride/ g Sulfate	0.17, g Chloride/ g Sulfate
Average Sulfate	0.04 g/m ³	0.33 g/m ³	0.46 g/m ³	0.78 g/m ³

^aSulfate given as ammonium sulfate

Table 3.4. UNMIX Source Composition of Sources Normalized for Nitrate.

Species	Primary Diesel Normalized for Nitrate ^a	Primary Auto Normalized for Nitrate ^a	Secondary (Daytime) Normalized for Nitrate ^a	Secondary (Nighttime) Normalized for Nitrate ^a
EC	1.08, ng EC/ g Nitrate	0.68, ng EC/ g Nitrate	32.29, ng EC/ g Nitrate	0.07, ng EC/ g Nitrate
UV	1.10, UV Units/ g Nitrate	1.00, UV Units/ g Nitrate	50.98, UV Units/ g Nitrate	0.07, UV Units/ g Nitrate
NO ₂	1.17, ppb NO ₂ / g Nitrate	27.32, ppb NO ₂ / g Nitrate	241.74, ppb NO ₂ / g Nitrate	0.95, ppb NO ₂ / g Nitrate
NO _x	3.57, ppb NO _x / g Nitrate	104.65, ppb NO _x / g Nitrate	172.41, ppb NO _x / g Nitrate	0.08, ppb NO _x / g Nitrate
O ₃	11.97, ppb O ₃ / g Nitrate	27.36, ppb O ₃ / g Nitrate	7882.98, ppb O ₃ / g Nitrate	25.11, ppb O ₃ / g Nitrate
H ₂ O ₂	0.01, ppb H ₂ O ₂ / g Nitrate	0.85, ppb H ₂ O ₂ / g Nitrate	155.87, ppb H ₂ O ₂ / g Nitrate	0.28, ppb H ₂ O ₂ / g Nitrate
Sulfate	0.12, g Sulfate/ g Nitrate	2.74, g Sulfate/ g Nitrate	154.91, g Sulfate/ g Nitrate	1.31, g Sulfate/ g Nitrate
Chloride	-0.01, g Chloride/ g Nitrate	1.00, g Chloride/ g Nitrate	20.96, g Chloride/ g Nitrate	0.22, g Chloride/ g Nitrate
Average Nitrate	0.33 g/m ³	0.12 g/m ³	0.00 g/m ³	0.60 g/m ³

^a Nitrate given as ammonium nitrate

Finally, the apportionments of sulfate and nitrate were done using the exact same data set. Total species for any source should be the same for these two results. This in fact, is the case for all species, indicating that the nitrate results are not artificially influenced by their lower precision. For example, the average amounts of primary diesel or primary auto nitrate calculated from the sulfate apportionment results are 0.34 and 0.12 $\mu\text{g}/\text{m}^3$, respectively. The corresponding amounts obtained in the UNMIX apportionment of nitrate are 0.33 and 0.12 $\mu\text{g}/\text{m}^3$, respectively. Similar agreement is seen through the two results for other species, as expected.

In summary, the various UNMIX calculations give comparable results where comparisons may be made, even when different assumptions are made in the UNMIX calculations. The various UNMIX results are self-consistent. While the fitting parameters for the $\text{PM}_{2.5}$ analysis are quite acceptable, the same parameters for sulfate and nitrate are less satisfactory. This is probably due to the lower concentrations, relative to the uncertainty of the measurements, for these two species. However, the comparisons made in this section suggest that the sulfate and nitrate results are quite consistent with the $\text{PM}_{2.5}$ results, and therefore, can be accepted as reasonable and useful. This is further supported by the observations made in the following section.

3.4.3. Comparison of UNMIX Results

The results for primary emissions are shown in Figure 3.9A for primary diesel emissions and Figure 3.9B for primary gasoline auto emissions. Shown with the primary diesel emissions are the concentrations of EC measured by the Anderson Aethalometer, which dominated the source profile for this source. The time patterns for the EC are identical to the diesel associated TEOM primary $\text{PM}_{2.5}$ mass and primary sulfate and by

Figure 3.9. a) UNMIX identified primary emissions of sulfate, nitrate and TEOM primary mass from diesel emissions all follow the time pattern of EC, the dominant marker for this source. b) In contrast the primary species from auto emissions follow the concentrations of NO_x and precede the EC emissions by 1- to 2-h.

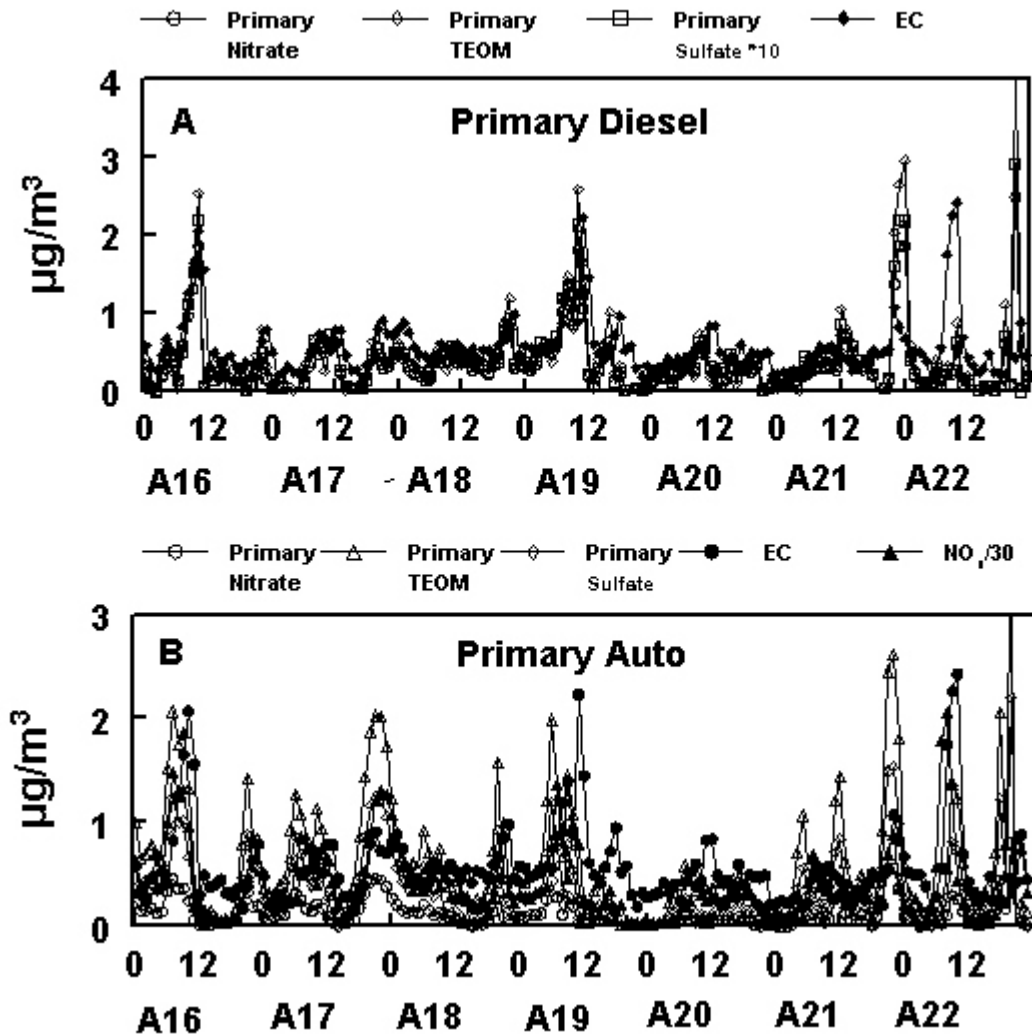

nitrate, indicating a common source for each of these species (see Figure 3.9A). Shown with the primary auto emissions are the concentrations of both EC and NO_x . NO_x was a dominant marker for primary auto emissions, and the concentrations of TEOM $\text{PM}_{2.5}$ mass, nitrate, and sulfate which UNMIX identified for the primary auto source show the same time patterns. Both primary diesel and primary auto sources show peaks in concentrations during morning and evening, which are consistent with local traffic patterns at the Lindon site. However, the concentrations of EC, associated with primary diesel emissions, lagged primary auto emissions by 1- or 2-h (e.g., see Figure 3.9B). This is consistent with traffic patterns for diesel-related mobile sources at the sampling site, e.g., truck traffic is highest after the morning automobile commute.

The source average composition of both primary diesel emission source profiles and primary automobile source profiles are given in Table 3.5. Source composition data were obtained by determining the average concentration of each of the species of interest over the source apportionment time period (August 16 - August 23). The percent composition was determined as the average concentration over the time period divided by the total of the average concentrations of all species (nitrate + NVOM + sulfate + EC). It is recognized that the sulfate and nitrate attributed to each source could include material emitted as NO_x and SO_2 and rapidly converted to particulate species.

The great bulk of the $\text{PM}_{2.5}$ mass was secondary species, which could be associated with the concentrations of NO_2 , O_3 and H_2O_2 . UNMIX results indicate there are at least three independent pathways for the formation of these secondary fine particulate components. The secondary components include most of the sulfate and nitrate and most likely most of the particulate organic material. Secondary source

Table 3.5. Average Source Compositions for Diesel and Automobile Emissions.

Species	Primary Diesel Emission		Primary Automobile Emissions	
	Average Concentration	Percent Contribution	Average Concentration	Percent Contribution
Nitrate	0.33 g/m ³	42 %	0.12 g/m ³	11 %
NVOM and other	0.29 g/m ³	37 %	0.56 g/m ³	51 %
Sulfate	0.04 g/m ³	5 %	0.33 g/m ³	31 %
EC	0.13 ng/m ³	16 %	0.06 ng/m ³	5 %

profiles were separated into daytime and nighttime formation processes as shown in Figure 3.10. Daytime source profile time patterns when normalized for PM_{2.5} TEOM mass, sulfate, and nitrate are identical, indicating a common source for each of these species. Concentrations of daytime source profiles show a time pattern with peaks at midday, consistent with atmospheric photochemical processes (Figure 3.10A). Shown with daytime emission source profiles are the concentrations of O₃ and H₂O₂. While both O₃ and H₂O₂ are associated with daytime photochemical process, the UNMIX apportioned daytime secondary material is most closely related to the time pattern for H₂O₂. This suggests that these secondary sources for TEOM PM_{2.5} mass, sulfate, and nitrate are most closely associated with the daytime photochemistry of H₂O₂. While specific apportionment for organic material was not done as part of this study, it is reasonable to assume that the H₂O₂ associated secondary TEOM mass is a combination of ammonium sulfate, ammonium nitrate, and secondary organic material. It is also reasonable to assume that the measured TEOM monitor mass does not include secondary nitrate. With these assumptions, the secondary material associated with daytime H₂O₂ formation given in Figure 3.10 is 31 % ammonium sulfate, 0.2% ammonium nitrate, and 69% nonvolatile secondary organic material.

Secondary formation processes, thought to be associated with nighttime chemistry, were also identified (Figure 3.10B). Nighttime attributed source profiles obtained when normalized for nitrate and sulfate concentrations show identical profiles, indicating a common source. When normalized for TEOM PM_{2.5} mass, a source profile is obtained that does not track the source profiles when normalized for nitrate and sulfate concentrations, indicating a separate formation process. All three of these profiles show

Figure 3.10. The UNMIX identified secondary emissions of A) secondary daytime formation processes and B) secondary nighttime formation processes.

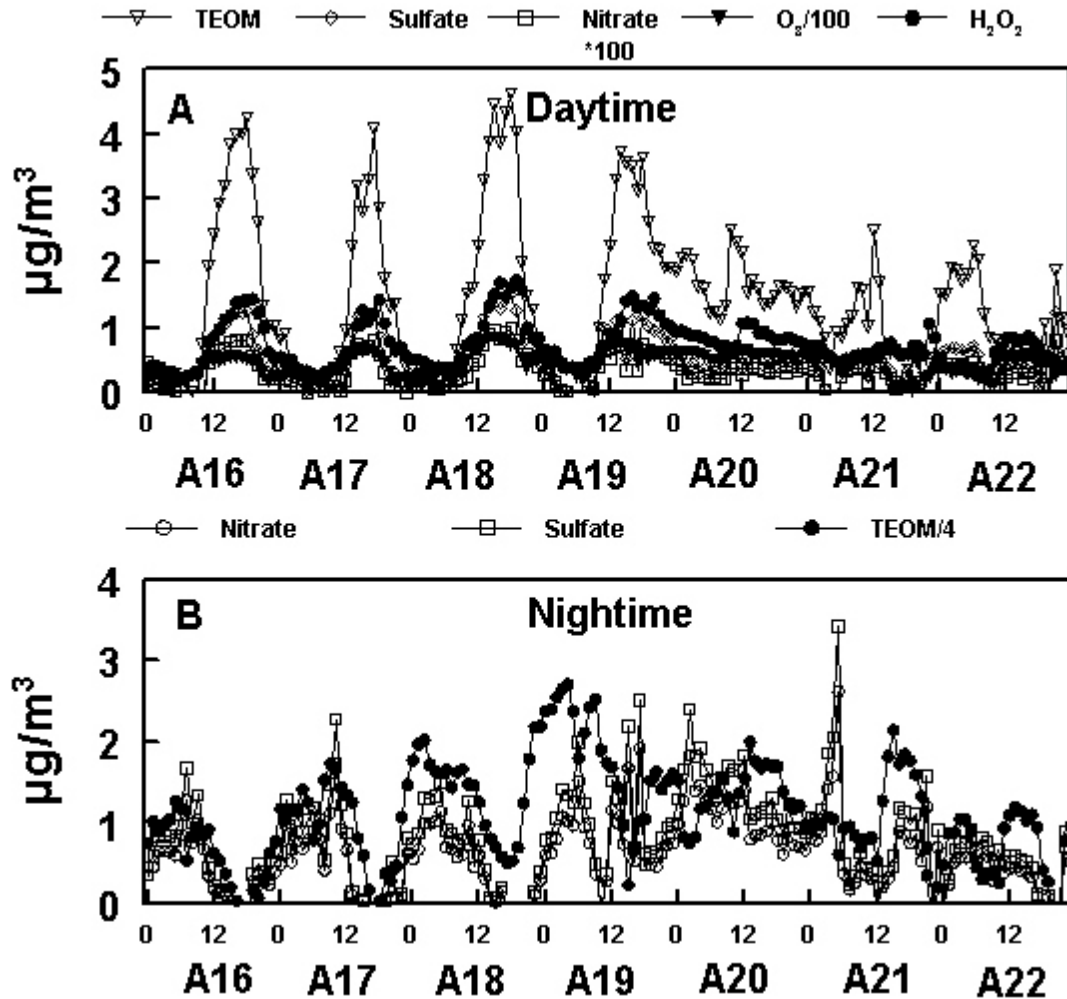

time patterns with maximum concentrations seen in the early morning hours. These profiles are consistent with patterns of the formation and destruction of nighttime inversion layers that normally occur during the summer along the Wasatch Front and, therefore, are most likely associated with nighttime chemistry and/or meteorology occurring at the Lindon sampling site. Therefore, two formation processes that may be associated with nighttime chemistry were identified using UNMIX. Using the same logic as given above, this will include ammonium sulfate, ammonium nitrate, and organic material. The nighttime secondary fraction averages 33% ammonium sulfate, 25% ammonium nitrate, and 42% nonvolatile secondary organic material.

3.5. Conclusions

The combination of $PM_{2.5}$ composition and mass data coupled with gas-phase data, can be used for the identification of major sources of fine particulate material using the EPA UNMIX program. One-h averaged data greatly increases the power of UNMIX to distinguish sources of both primary and secondary emissions. In this study, UNMIX was able to identify sources of primary sulfate, nitrate, and primary TEOM $PM_{2.5}$ mass. Primary sources associated with diesel emissions and auto emissions were identified. EC concentrations and UV measurements are highly correlated with primary diesel emissions. Primary auto emissions are correlated with NO_x concentrations. UNMIX was also able to identify secondary sources of fine particulate matter, which can be attributed to daytime and nighttime chemistry. Secondary daytime chemistry source profiles are highly correlated with O_3 and H_2O_2 concentrations. Nighttime chemistry source profiles are consistent with the daily formation and destruction of nighttime inversion layers.

UNMIX results suggest one formation processes for daytime secondary sources, highly correlated with H₂O₂, and two separate formation processes for nighttime secondary sources. Both the daytime and nighttime processes include the formation of secondary ammonium sulfate, ammonium nitrate, and organic material.

3.6. References

Al-Horr, R., Samantha, G., and Dasgupta, P.K. A Continuous Analyzer for Soluble Anionic Constituents and Ammonium in Atmospheric Particulate Matter. Submitted to *Aerosol. Sci. Technol.*

Boring, C.B., Al-Horr, R., Genfa, Z., Dasgupta, P.K., Martin M.W., and Smith, W.F. (2002). Field Measurements of Acid Gases and Soluble Anions in Atmospheric Particulate Matter using a Parallel Plate Wet Denuder and Alternating Filter-Based Automated Analysis System. *Anal. Chem.* 74: 1256-1268.

Dasgupta, P.K., Poruthoor, S.K. (2002). *Comprehensive Analytical Chemistry, 37th ed.*, J. Pawliszyn, ed., Elsevier Science B.V., Amsterdam, 2002; pp 161-276.

Ding, Y., Pang, Y., Eatough, D.J., Eatough, N.L., and Tanner, R.L. (2002a). High-Volume Diffusion Denuder Samplers for the Routine Monitoring of Fine Particulate Matter: I. Design and Optimization of the PC-BOSS. *Aerosol Sci. Technol.* 36: 369-382.

Ding, Y., Pang, Y., Eatough, D.J., Eatough, N.L., and Tanner, R.L. (2002a). High-Volume Diffusion Denuder Samplers for the Routine Monitoring of Fine Particulate Matter: II. Field Evaluation of the PC-BOSS. *Aerosol Sci. Technol.* 36: 383-396.

Eatough, D.J., Obeidi, F., Pang, Y., Ding, Y., Eatough, N.L., and Wilson, W.E. (1999). Integrated and real-time diffusion denuder samplers for PM_{2.5} based on BOSS, PC and TEOM technology. *Atmos. Environ.* 33: 2835-2844.

Eatough, D.J., Eatough, N.L., Obeidi, F., Pang, Y., Modey, W., and Long, R. (2001) Continuous determination of PM_{2.5} mass, Including Semi-Volatile Species. *Aerosol Sci. Technol.* 34, 1-8.

Eatough, D.J., Long, R.W., Modey, W.K., Eatough, N.L. (2003). Semi-Volatile Secondary Organic Aerosol in Urban Atmospheres: Meeting a Measurement Challenge. *Atmos. Environ.* 37: 1277-1292.

Hansen, A.D.A (2002). *The Aethalometer Operating Manual*, http://www.mageesci.com/Aethalometer_book_2002.06.5.pdf, accessed September 16, 2002.

Henry, R.C., and Norris, G.A. (2001). EPA UNMIX 2.3 user guide.

Hering, S.; Cass, G. The Magnitude of Bias in the Measurement of PM_{2.5} Arising from Volatilization of Particulate Nitrate from Teflon Filters. *J. Air & Waste Manage. Assoc.* 49: 725-733.

Lewis, C.W., Norris, G.A., Conner, T.L., and Henry, R.C. (2003). Source Apportionment of Phoenix PM_{2.5} Aerosol with the UNMIX Receptor Model. *J. Air & Waste Manage. Assoc.* 53: 325-338.

Lewtas, J., Booth, D., Pang, Y., Reimer, S, Eatough, D.J., and Gundel, L. (2001). Comparison of sampling methods for semi-volatile organic carbon (SVOC) associated with PM_{2.5}. *Aerosol Sci. Technol.* 34: 9-22.

Li, J.; Dasgupta, P.K. (2000). Measurement of Atmospheric Hydrogen Peroxide and Hydroxymethyl Hydroperoxide with a Diffusion Scrubber and Light Emitting Diode-Liquid Core Waveguide-Based Fluorometry. *Analytical Chemistry.* 72: 5338-5347.

Long, R.W., Smith, R., Smith, S., Eatough, N.L., Mangelson and Eatough, D.J. (2002) Sources of Fine Particulate Material along the Wasatch Front, *Energy and Fuels.* 16: 282-293.

Long, R.W., Eatough, N.L., Mangelson, N.F., Thompson, W., Fiet, K., Smith, S., Smith, R., Eatough, D.J., Pope, C.A., and Wilson, W.E. (2003). The Measurement of PM_{2.5}, Including Semi-Volatile Components, in the EMPACT Program: Results from the Salt Lake City Study. *Atmos. Environ.*, 37(31): 4407-4417.

Mignacca, D., Stubbs, K. (1999) Effects of Equilibration temperature on PM₁₀ Concentrations from the TEOM Method in the Lower Fraser Valley. *J. of Air & Waste Manage. Assoc.* 49: 1250-1254.

Musick, D. (2000) A Summary of the Ambient Air Program for PM_{2.5} *Environ. Manager.* 17-20.

Patashnick, H., Rupprecht, E. G. (1991) Continuous PM₁₀ measurements using the tapered element oscillating microbalance. *J. of Air & Waste Manage. Assoc.* 41: 1079-1083.

Pope, C.A. III (2000). Epidemiology of fine particulate air pollution and human health; Biological mechanisms and who's at risk? *Environ. Health Perspect.* 108(Sup 4): 713-723.

Schaefer, G., Hamilton, W., Mathai, C.V. (1997). Implementing the revised NAAQS and the FACA subcommittee for ozone, particulate matter and regional haze. *Environ. Manager*, 22-28.

Sioutas, C., Koutrakis, P., and Burton, R.M. (1994). Development and Evaluation of a Low Cutpoint Virtual Impactor. *Aerosol Sci. Technol.* 21: 223-235.

Schwartz, J., Dockery, D.W., Neas, L.M., (1996). Is daily mortality associated specifically with fine particles? *J. Air & Waste Manage. Assoc.* 46: 927-939.

Tang, H., Lewis, E. A., Eatough, D. J., Burton, R. M., and Farber, R. J. (1994). Determination of the particle size distribution and chemical composition of semi-volatile organic compounds in atmospheric fine particles. *Atmos. Environ.* 28: 939-947.

Turpin, B.J., and Lim, H.J. (2001). Species Contributions to PM_{2.5} Mass Concentrations: Revisiting Common Assumptions for Estimating Organic Mass. *Aerosol Sci. Technol.* 35: 602-610.

Wilson W.E.; Suh, H.H. (1997). Fine Particles and Coarse Particles: Concentration Relationships Relevant to Epidemiologic Studies. *J. Air & Waste Manage. Assoc.* 47: 1238-1249.

Chapter 4. Measurement of Total PM_{2.5} Mass (Nonvolatile plus Semi-Volatile) with the FDMS TEOM Monitor

4.1. Overview

It is desirable to monitor PM_{2.5} on a continuous basis. Such data would allow for better understanding of atmospheric processes and sources which contribute to fine particulate pollution and for timely public reporting and forecasting of air pollution exposure. An instrument commonly used for this purpose is the TEOM monitor (Patashnick and Rupprecht, 1991). However, semi-volatile nitrate and OM associated with fine particles is not accurately measured with a conventional TEOM monitor because the filter is heated to avoid collection of particle-bound water (Long *et al.*, 2003; Mignacca and Stubbs, 1999). The RAMS (Eatough *et al.*, 2003; 2000) is a modified TEOM monitor with a combination of a particle-collection filter (TX40) and a charcoal-impregnated, glass-fiber filter on the oscillating tapered element of a TEOM monitor to retain the semi-volatile species and allow determination of total PM_{2.5} mass, including the semi-volatile species. The RAMS uses diffusion denuders and Nafion dryers to remove interfering gas phase material, including water, from the aerosol prior to the collection of particles. While the RAMS does measure total PM_{2.5} mass, including semi-volatile ammonium nitrate and SVOM, the sampler is not suitable for routine use in field sampling because it requires regular observation and maintenance.

R&P recently developed the differential TEOM monitor as a reference standard for particulate matter mass as described by Patashnick *et al.*, 2001, and subsequently developed the Filter Dynamics Measurement System (FDMS, Meyer *et al.*, 2002), both of which attempt to correct for loss of SVM from the TEOM filter by alternately making

measurements with particle-containing and particle-free air passing through the filters on the tapered element oscillating microbalance of a TEOM monitor. In this study, the new FDMS monitor was evaluated by comparison of measurements with a RAMS and a differential TEOM system similar to that described by Meyer *et al.*, (2002). In addition, integrated average particulate mass and composition data were obtained using the PC-BOSS (Lewtas *et al.*, 2001) which provides an alternate method for the measurement of non-volatile and SVM, to allow interpretation of any differences which may be seen between the FDMS and RAMS monitors. Measurements have been made during field studies in January - February 2003 in Lindon, UT and July 2003 in Rubidoux, CA. This chapter compares the various results from these studies related to the measurement of semi-volatile $PM_{2.5}$ with the FDMS monitor.

4.2. Sampling Methods

R&P TEOM Monitor. One-h averaged, nonvolatile $PM_{2.5}$ mass concentrations were determined using an R&P TEOM monitor heated above ambient temperature to avoid water condensation (Patashnick and Rupprecht, 1991). As stated previously, semi-volatile PM will evaporate at the standard operating temperature of the instrument (50° C, 30° C during winter months), which is required to remove particle-bound water (Eatough *et al.*, 2003; Long *et al.*, 2003; Mignacca and Stubbs, 1999). This technique measures non-volatile PM. In this study the TEOM was used to obtain a direct measurement of the mass without the corrections normally used to give better agreement with the FRM samplers.

R&P FDMS. The Rupprecht and Patashnick Filter Dynamics Measurement System (FDMS, Series 8500) is designed to account for both the semi-volatile and non-

volatile components of particulate matter, reporting the combination as a mass concentration result. This result is accomplished by measuring the semi-volatile portion of the sample independently from the total incoming sample, and using this fraction in calculating the PM_{2.5} mass concentration. The operation of the FDMS was detailed in Chapter 2. One-h averaged concentrations of total PM_{2.5} were obtained with the FDMS.

R&P Differential TEOM Monitor. The Differential TEOM monitor is an R&P research instrument as outlined in Chapter 2. The Differential TEOM was used in this study to obtain 1-h total PM_{2.5} mass measurements for comparison with other semi-continuous mass monitors.

RAMS. The real-time total ambient mass sampler (RAMS), based on diffusion denuder, Nafion dryer and TEOM monitor technology, was used for the real-time determination of total PM_{2.5} mass, including SVM (Eatough *et al.*, 2000) throughout the study. The theory and operation of the RAMS was discussed in detail in Chapter 2. 1-h total PM_{2.5} mass concentrations were obtained throughout the study with the RAMS.

GRIMM Model 1100 Monitor. A conventional GRIMM monitor was used to measure hourly averaged PM_{2.5} at ambient temperature. A collocated GRIMM monitor was also applied in this study which used an inlet equipped with a heater operated at 80 °C, resulting in a temperature of 50 °C in the laser measured aerosol, for comparison with heated TEOM mass data. The operation of these instruments was detailed in Chapter 2.

PC-BOSS. The PC-BOSS was used for sample collection to determine fine particulate mass, sulfate, carbonaceous material (elemental and organic), nitrate, SVOM, and semi-volatile nitrate. The configuration and operation of the PC-BOSS, as used in

this study, was discussed in detail in Chapter 2. Multiple 3-h samples were collected at selected time periods at each sampling site for comparison with 3-h averaged FDMS TEOM, Differential TEOM, and RAMS results. PC-BOSS filters were analyzed by TPV and IC as outlined in Chapter 2 and $PM_{2.5}$ mass was obtained using a microbalance as stated in Chapter 2.

R&P Continuous Nitrate Monitor. Hourly-averaged fine particulate nitrate concentrations were determined using an R&P Model 8400N nitrate monitor (Long *et al.*, 2004). The operation of the 8400N was discussed in Chapter 2.

Sunset Laboratory Carbon Aerosol Field Instruments. Two collocated Sunset carbon monitors equipped with a common 2.5 μm sharp cut cyclone (R&P) were employed in this study. Eight L/min of the flow was directed to the carbon monitor and the remaining flow was directed to a modified Sunset instrument. After the flow split, the sampled air passed through a parallel plate charcoal impregnated filter denuder similar to that described for the BYU RAMS (Eatough *et al.*, 2000) and supplied by Sunset Laboratory with the instrument. This denuder is intended to remove gas phase organic compounds which can be absorbed by a quartz filter, thus eliminating any positive quartz filter artifact for the data obtained with the monitor (Eatough *et al.*, 2003; Turpin and Huntzicker, 1994). The particles in the sampled air stream were then collected on a 12.3 mm diameter quartz filter for a controlled time period (45-min in the study reported here). Sample analysis was then performed as outlined in Chapter 2.

A second Sunset monitor was modified to allow for the determination of semi-volatile organic carbonaceous material, SVOC, lost from particles during the 45-min sample collection period. The modified instrument sampled the second of the two split

flow lines after the sharp cut cyclone inlet. A diffusion denuder, identical to that used in the unmodified instrument, removed gas phase material with an expected efficiency of better than 99%. After the removal of the gas phase material, the particles were removed from the sampled air stream immediately before the entrance to the Sunset monitor using a pre-fired (800 °C) 47-mm quartz filter in a MACE in-line, Teflon filter holder. The particle-free air (with any SVOC lost from the particles during sample collection) passed into the filter collection region of the Sunset monitor. The quartz filter normally used in the unmodified instrument was preceded by a charcoal impregnated glass fiber filter (CIG, Schleicher and Schuell, Dassell, Germany). The quartz filter was kept after the CIG to provide additional support for the CIG filter. Any SVOC lost from particles collected on the inlet quartz filter were collected with high efficiency by this CIG filter. At the end of the 45-min sampling period, the SVOC collected on the CIG was analyzed by thermal evolution. This analysis was done in a three-step temperature program in a He atmosphere to separate any gas phase VOC not removed by the denuder from fine particulate SVOC. Details of the measurements with the two Sunset instruments are further discussed in Chapter 8 (Grover *et al.*, 2004).

4.3. Sample Collection

Initial studies were conducted in February 2003 in Lindon, UT. The Lindon sampling site was previously described in Chapter 3 (Long *et al.*, 2003). In these experiments, results obtained with the FDMS were compared to 1-h averaged $PM_{2.5}$ mass determined with a conventional TEOM monitor operated at 30 °C, to results obtained with a RAMS, and also to $PM_{2.5}$ mass determined in 3-h integrated samples with the PC-BOSS. More extensive studies were conducted during July 2003 at the South Coast Air

Quality Monitoring District (SCAQMD) sampling site in Rubidoux, CA. In these studies, both the FDMS and Differential TEOM monitors were used. Results were compared with 1-h averaged RAMS and TEOM monitor measurements, 1-h average R&P particulate nitrate measurements, 1-h average Sunset Laboratory nonvolatile and semi-volatile carbon measurements, and 3-h integrated PC-BOSS sampler results. Particle separation for all continuous mass measurements was done with an R&P16.67 L/min PM_{10} inlet followed by an R&P 2.5 μm sharp cut cyclone.

4.4. Results

4.4.1. Lindon Study FDMS and RAMS Results.

One-h average $PM_{2.5}$ mass measured in Lindon, UT during a two week period in January - February 2003 using the RAMS and the FDMS are given in Figure 4.1. There was good agreement between the RAMS and the FDMS results as shown in Figure 4.1 and Table 4.1. Linear regression analysis results and the bias corrected precision of the comparison are given in Table 4.1. The precision of the comparison is limited by the expected ± 2 to 3 $\mu g/m^3$ uncertainty in the RAMS data (Eatough *et al.*, 2003; Long *et al.*, 2003). The uncertainty in the comparison was $\sigma = \pm 2.8 \mu g/m^3$ ($\pm 21\%$), consistent with the expected precision of the RAMS results. Therefore, within the precision of the RAMS measurement, the RAMS and FDMS results agreed.

4.4.2. Rubidoux Study FDMS, Differential TEOM, RAMS and GRIMM Results.

Both an FDMS and a differential TEOM monitor were used at Rubidoux. The results obtained with these two instruments, when both instruments were operational, are

Figure 4.1. Data from the Lindon 2003 Study. 1-h average $PM_{2.5}$ mass determined with the RAMS and FDMS in Lindon, UT during January and February, 2003.

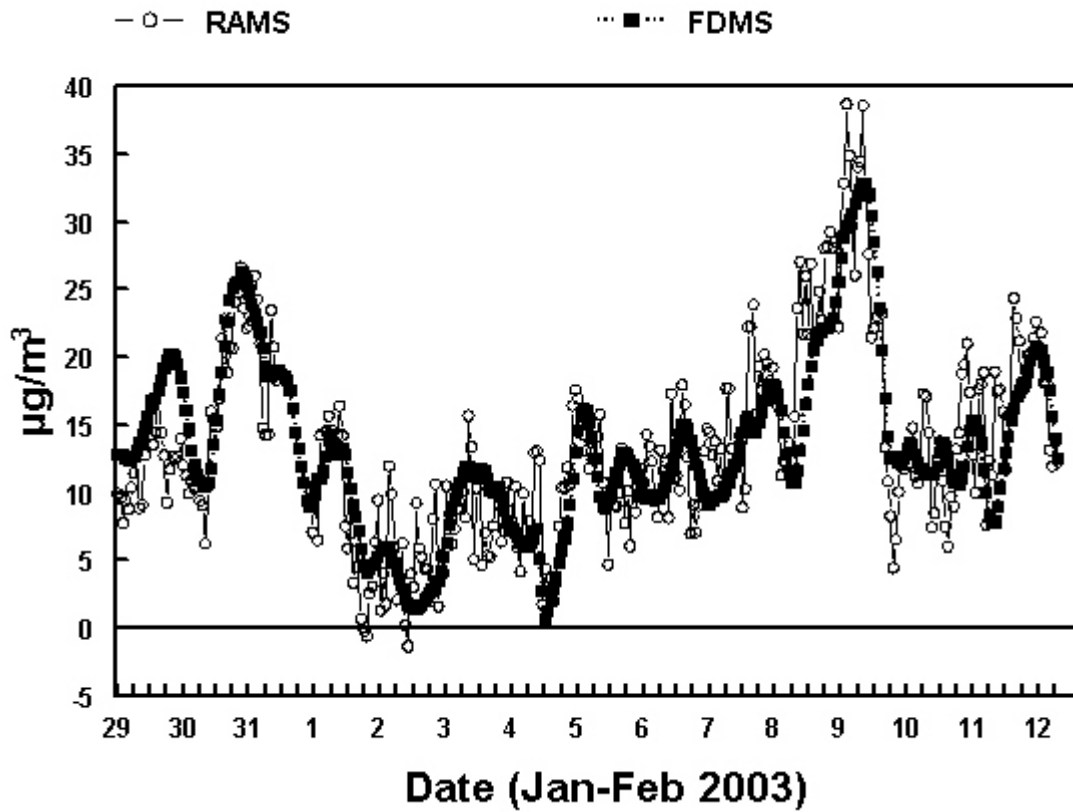

Table 4.1. Results of the Statistical Analysis of PM_{2.5} Measurements During the Lindon and Rubidoux Studies.

X vs Y	n	r ²	slope ^a	intercept g/m ³	X Average g/m ³	X-Y Bias g/m ³	g/m ³	%
Lindon								
FDMS vs RAMS	332	0.69 0.69	1.00±0.01 0.92±0.03	0 ±4.0 1.3±3.9	13.5	0.2	2.8	20.9
FDMS vs PC-BOSS	11	0.63 0.66	1.01±0.06 0.89±0.21	0±2.7 1.8±2.8	13.0	0.3	1.8	13.9
Rubidoux								
FDMS vs Diff TEOM ^{a,e}	426	0.85 0.85	0.97±0.01 0.98±0.02	0±5.3 -0.6±5.3	34.6	1.2	3.8	11.2
FDMS vs RAMS ^a	337	0.80 0.81	0.99±0.01 0.93±0.02	0±8.2 2.4±8.2	34.6	0.4	5.9	16.8
FDMS vs GRIMM ^a	434	0.51 0.70	1.04±0.01 0.70±0.02	0±7.7 13.5±6.0	34.1	3.1	5.6	15.5
PC-BOSS vs FDMS ^b	33	0.90 0.90	0.96±0.02 0.96±0.08	0±3.9 -3±3.9	39.4	1.8	3.0	7.7
FDMS vs FRM ^c	29	0.87 0.90	0.70±0.02 0.96±0.06	0±3.3 -9.3±3.9	35.8	11.3	NA ^d	
PC-BOSS vs R&P Nitrate ^b	31	0.61 0.73	0.89±0.04 0.65±0.07	0±2.9 3.3±2.4	10.8	0.5	2.2	21.0
PC-BOSS vs Sunset C ^b	21	0.91 0.93	0.99±0.02 0.90±0.06	0±2.2 2.0±2.1	18.8	-0.1	1.8	9.6

^a 1-h average results.

^b 3-h average results.

^c 24-h average results.

^d NA, could not be calculated because of the large bias.

^e 38 peak concentrations with bias greater than 15 µg/m³ (FDMS > Diff TEOM) not included in statistical analysis.

given in Figure 4.2A. The two measurements are generally in good agreement. Significant exceptions occurred only at peak concentrations. Of the total 474 data points, the 38 peak values have FDMS concentrations which are biased $21 \mu\text{g}/\text{m}^3$ higher than the differential TEOM concentrations. The reasons for this bias are not currently understood. Linear regression analysis of the FDMS and differential TEOM data, (excluding the 38 peak concentrations) are shown in Table 4.1 and Figure 4.3. The average concentration is $34.6 \mu\text{g}/\text{m}^3$ and the FDMS concentrations are biased only $1.2 \mu\text{g}/\text{m}^3$ higher than the differential TEOM concentrations. The bias corrected uncertainty in the comparison is $\sigma = \pm 3.8 \mu\text{g}/\text{m}^3$ ($\pm 11\%$).

Comparison between the FDMS and RAMS measurements are shown in Figure 4.2B. Note that the data points in Figures 4.2A and 4.2B are not completely the same because of some differences when the various instruments were producing valid data. The very high concentrations in Figure 4.2B are associated with fireworks and a local fire near the Rubidoux site on the night of July 4. Differential TEOM data were not obtained during the July 4 time period. The FDMS and RAMS measurements are generally in agreement. The uncertainty in the RAMS data during the 1 to 9 July period is about three times larger than that of the RAMS data during the latter part of the study. The poor precision was due to incomplete control of humidity in the RAMS measurements during the first part of the study. The humidity control in the RAMS was improved after July 9. This same problem was evident in only a small fraction of the samples after July 18. Linear regression analysis statistics of the FDMS and RAMS data (for the valid data during both the 1-9 and 18-31 July time periods) are given in Table 4.1. The uncertainty

Figure 4.2. Data from the Rubidoux July 2003 study. (A) Comparison of 1-h average FDMS and Differential TEOM $PM_{2.5}$ mass measurements. (B) Comparison of 1-h average FDMS and RAMS $PM_{2.5}$ mass measurements. (C) Comparison of 1-h average FDMS and 50 °C TEOM monitor $PM_{2.5}$ mass measurements.

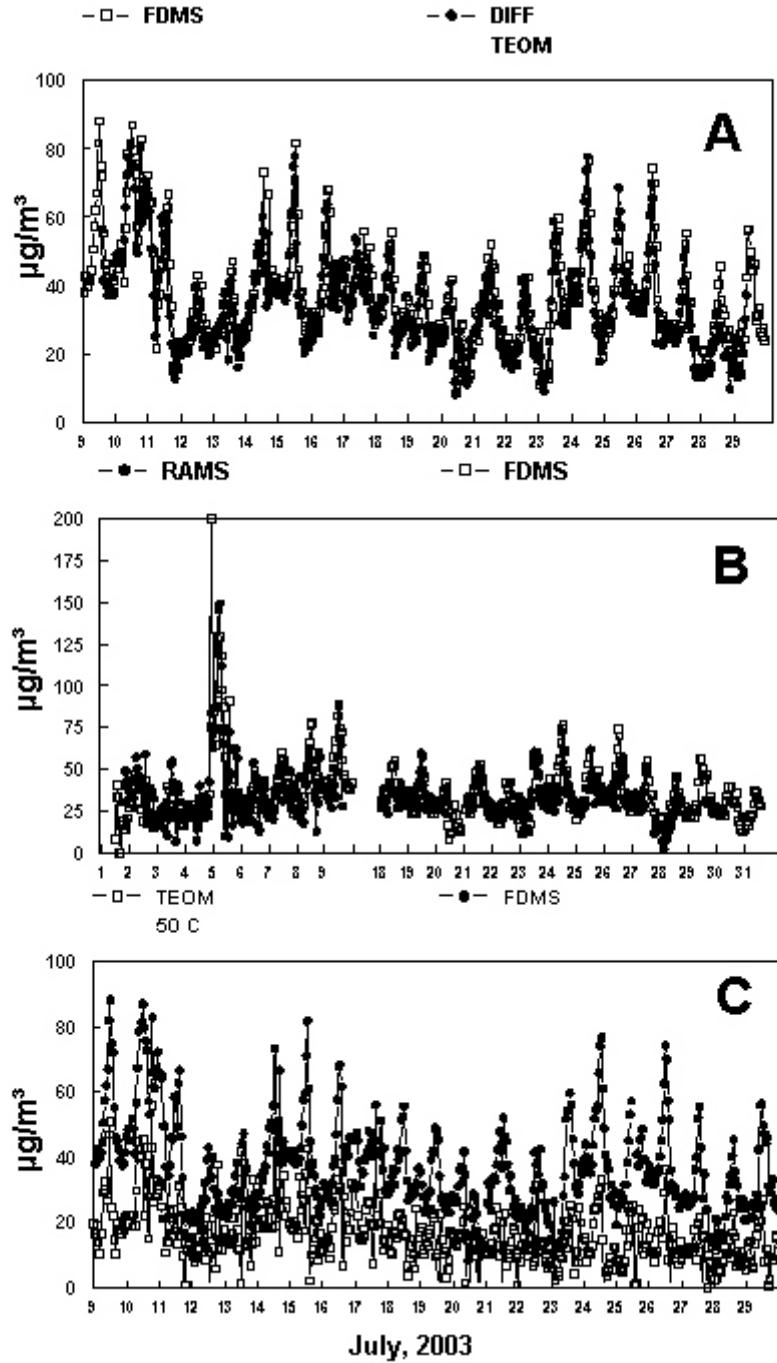
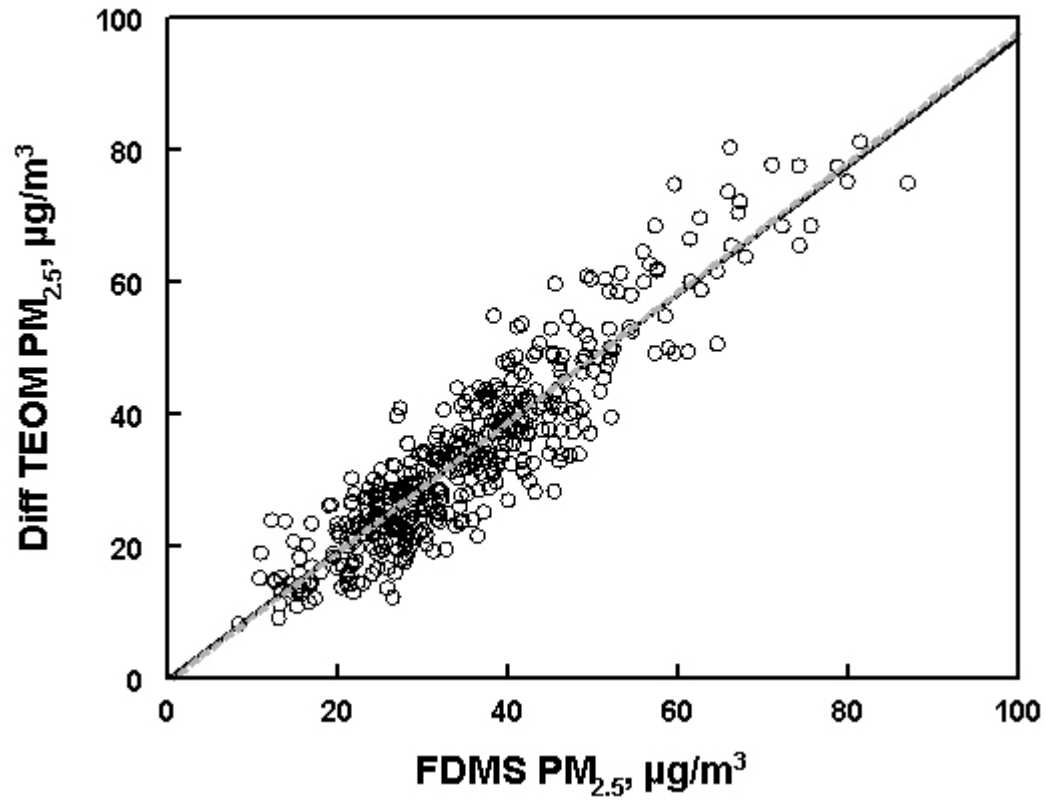

Figure 4.3. Comparison of 1-h average $PM_{2.5}$ mass determined with the FDMS and differential TEOM in Rubidoux, CA. The solid line is the regression slope with a zero intercept and the dashed line is the regression line with a calculated intercept.



in the comparison is $\sigma = \pm 5.8 \mu\text{g}/\text{m}^3$ ($\pm 17\%$) and is again limited by the precision of the RAMS data. The average concentration for these samples was $30.6 \mu\text{g}/\text{m}^3$ and the bias between the RAMS and FDMS data sets was only $0.4 \mu\text{g}/\text{m}^3$. The RAMS and FDMS $\text{PM}_{2.5}$ data were in agreement.

The FDMS and 50°C TEOM data are given in Figure 4.2C. As expected, high concentrations of ammonium nitrate and semi-volatile organic material, as detailed below, result in the concentrations measured with the heated filter of the TEOM monitor being substantially lower than those obtained with the FDMS, differential TEOM, or RAMS monitors.

A GRIMM monitor was operated during the study for the measurement of $\text{PM}_{2.5}$ mass. Comparison of measured mass with the FDMS monitor is given in Figure 4.4A with linear regression statistics shown in Table 4.1. Generally GRIMM monitor results tracked FDMS results during the study period. Peaks in the $\text{PM}_{2.5}$ concentrations generally occurred during the mid-day period for each sampling day. This was a time of significant secondary ammonium nitrate and SVOM formation. Relative humidity (% RH) was general low during this mid-day time period as shown in Figure 4.5. The GRIMM and the FDMS monitor results are in good agreement during these periods of low %RH, indicating that the protocols used to convert the GRIMM monitor volume distribution data to a $\text{PM}_{2.5}$ mass concentration are robust. During the overnight periods of high %RH, the results obtained with the GRIMM monitor are consistently higher than the results obtained with the FDMS monitors. The difference between the FDMS and the GRIMM mass measurement is shown in Figure 4.5 as FDMS-GRIMM. The FDMS and differential TEOM monitors are not expected to measure fine particulate water content

Figure 4.4. Comparison of mass measurements at Rubidoux, CA made with (A) a conventional GRIMM monitor and the FDMS and (B) a GRIMM monitor equipped with a heated inlet and a TEOM monitor operating at 50 °C.

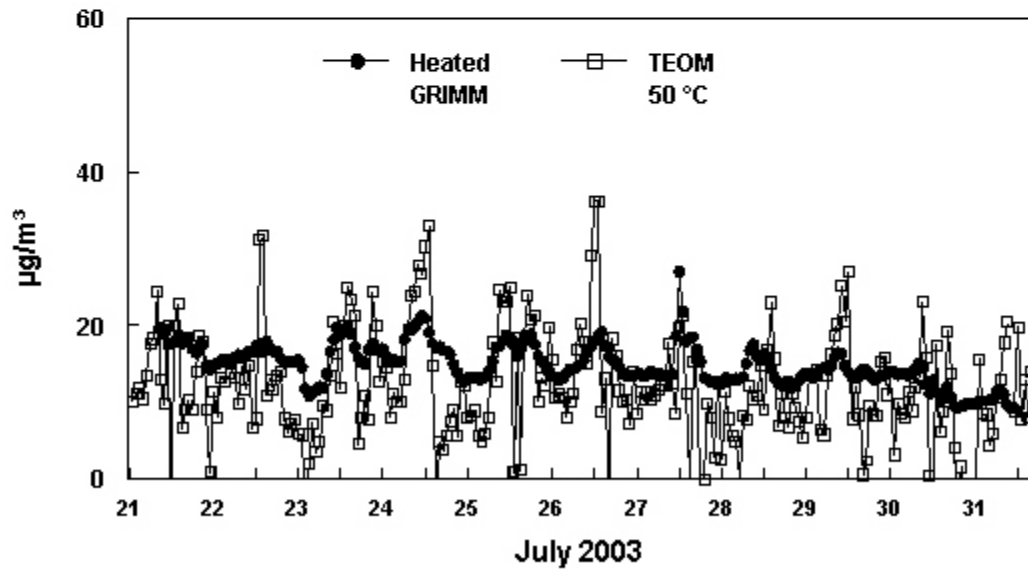
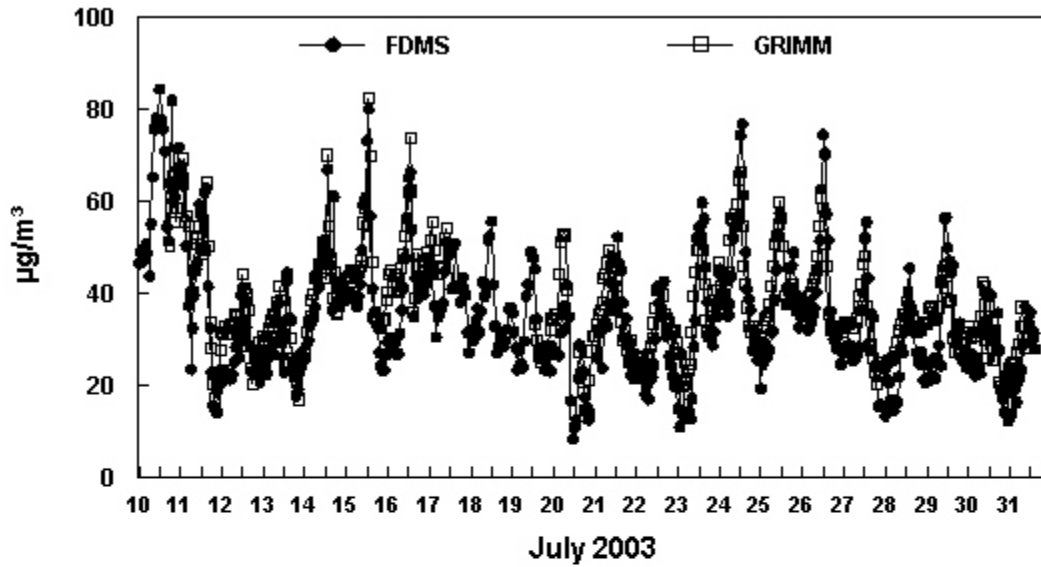
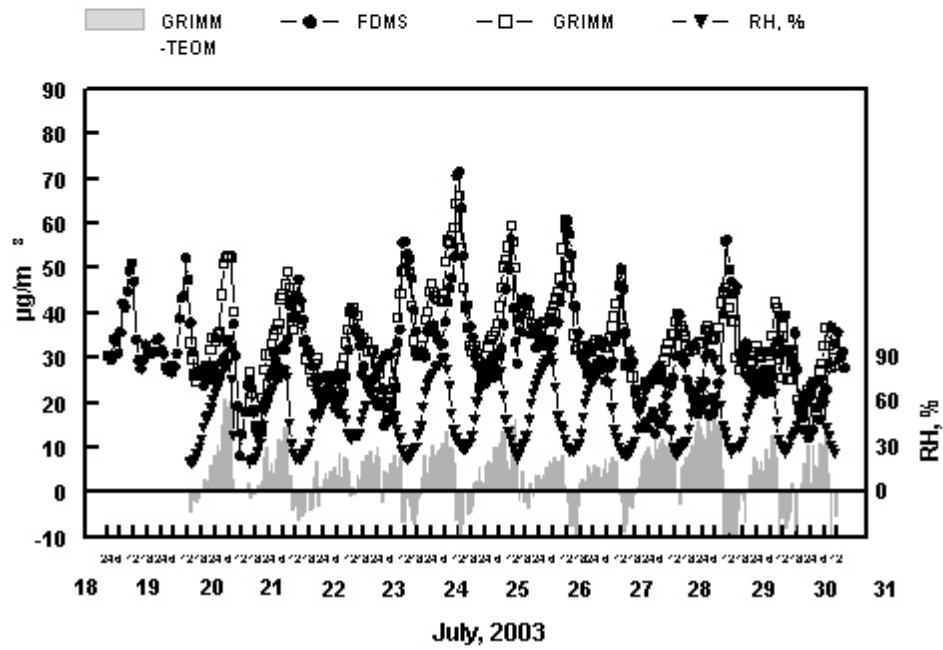
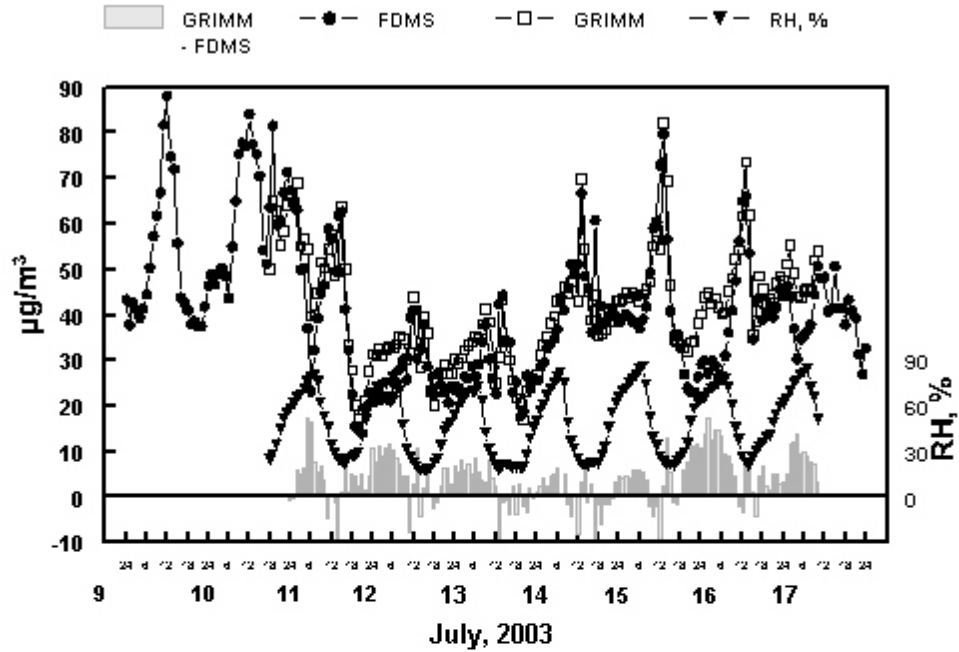

Figure 4.5. Difference between the FDMS and GRIMM monitor mass measurements (shown as FDMS-GRIMM) and %RH at Rubidoux, CA.



due to the use of Nafion dryers. However, the GRIMM does not remove particle bound water. Aerosols with high concentrations of ammonium nitrate, ammonium sulfate, and soluble organic salts can be highly hygroscopic. Because the GRIMM monitor uses a light scattering technique to estimate the mass of particles in the aerosol, it is possible that the higher mass concentrations measured during the high %RH time periods may reflect the increased volume of aerosol associated with fine particulate water.

Additional information on mass measurement by the GRIMM monitor were obtained by comparison of the GRIMM monitor results with those obtained with a conventional TEOM monitor operating at 50 °C and a GRIMM monitor with an inlet heated to 80 °C resulting in an inlet temperature of 50 °C. These data were obtained during the later part of the study and are shown in Figure 4.4B. As expected, both the heated TEOM and heated GRIMM results give PM_{2.5} measurements which are lower than obtained with the other instruments. This can be attributed to the loss of some of the semi-volatile ammonium nitrate and SVOM from the sampled particles at the elevated temperature. The 50 °C TEOM monitor results tend to be somewhat lower than the GRIMM measurements and to have greater diurnal variability. This can probably be attributed to the retention of particles on the heated filter of the TEOM monitor with subsequent continued loss of SVM over time as the composition of the sampled aerosol changes. The difference between the unheated GRIMM and comparison samplers which was attributed above to the measurement of fine particulate water content by the GRIMM monitor is not evident in the heated GRIMM monitor results. This is expected at the elevated temperature of the sampled aerosols in the heated GRIMM monitor because the heated inlet is above the deliquescence point of the aerosol.

4.5. Discussion

A second check on the accuracy of the FDMS data for each sampling site was made by comparison with the constructed mass obtained from the PC-BOSS integrated samples. Sulfate and nitrate were assumed to be present as the ammonium salts. Both NVOM and SVOM were assumed to be 62% C (Turpin and Lim, 2001). For the Lindon site, the PC-BOSS data were obtained on a 3-h average basis (about 3 samples/day) on January 29 and February 7-8 and 10-12 (see Figure 4.1). Linear regression analysis statistics of the FDMS and PC-BOSS data are given in Table 4.1. The intercept calculated slope is lower, but the uncertainty in the slope includes unity and the uncertainty in the intercept includes zero. The uncertainty in the comparison of the FDMS and PC-BOSS $PM_{2.5}$ results was $\sigma = \pm 1.8 \mu\text{g}/\text{m}^3$ ($\pm 14\%$), consistent with the expected precision of the PC-BOSS results. In contrast, the measurements obtained with the 30 °C TEOM monitor and the FDMS unit were very different. The 30 °C TEOM monitor gave an average $PM_{2.5}$ concentration (N = 265) of $6.1 \mu\text{g}/\text{m}^3$. For the same data points, the FDMS unit averaged $14.8 \mu\text{g}/\text{m}^3$. The mass measured with the 30 °C TEOM monitor was consistently lower than that measured with the FDMS unit. The difference between the two measurements is consistent with the concentrations of SVOM and ammonium nitrate measured with the PC-BOSS sampler.

The precision of two of the components included in the calculation of the PC-BOSS calculated mass for the Rubidoux study can be estimated by comparison with an independent measurement of that component by a second sampler. Either 4 or 8 3-h PC-BOSS samples were collected on July 2, 8, 11, 16, 17, 23, 26 and 30. In addition, a single 24-h PC-BOSS sample was collected on July 5, 14, 26 and 29. These 24-h

samples were collected on days when speciation sampler results were available. The fine particulate nitrate concentrations were determined in both 1-h averaged measurements with the R&P nitrate monitor and 3-h average measurements with the PC-BOSS. The R&P nitrate data were obtained over the time period from July 9 through 20. The R&P nitrate data were averaged over the PC-BOSS 3-h sampling time periods. These data are compared to the PC-BOSS fine particulate nitrate concentrations in Table 4.1. There is a definite bias between the two measurements at the higher concentrations, with the PC-BOSS data being higher in concentration. It has been suggested that this difference is due to incomplete volatilization of the sampled ammonium nitrate at higher concentrations (and higher relative humidity) for the R&P monitor (Long *et al.*, 2004).

If only the concentrations below $20 \mu\text{g}/\text{m}^3$ are included in the regression analysis, the zero intercept slope ($n = 31$, $R^2 = 0.44$) is 0.96 ± 0.06 and the precision of the comparison is $\sigma = \pm 2.0 \mu\text{g}/\text{m}^3$ ($\pm 20\%$). This result is taken as an estimate of the uncertainty in the PC-BOSS nitrate results. The corresponding uncertainty in ammonium nitrate is $\pm 2.6 \mu\text{g}/\text{m}^3$. The uncertainty in ammonium sulfate can be estimated by comparison with 24-h SCAQMD speciation sampler results ($N = 10$) to be $\pm 1.9 \mu\text{g}/\text{m}^3$. The uncertainty in the PC-BOSS ammonium nitrate results obtained by comparison with the SCAQMD speciation sampler results ($N = 9$) is $\pm 2.1 \mu\text{g}/\text{m}^3$.

The second 1-h average $\text{PM}_{2.5}$ component which can be compared to the PC-BOSS results is total fine particulate carbonaceous material. Both nonvolatile and semi-volatile fine particulate carbonaceous material were determined using the PC-BOSS and the two Sunset monitors (Grover *et al.*, 2004). The Sunset measurements were available for the time period from 13 through 26 July. Comparison between these two

measurements is given in Table 4.1. As indicated, the two measurements are in good agreement. Assuming that the organic material is 62% carbon (Turbin and Lim, 2001) the uncertainty in the comparison of these two measurements is $\pm 2.9 \mu\text{g}/\text{m}^3$. The combination of the ammonium nitrate, ammonium sulfate and carbonaceous material precision estimates leads to an expected uncertainty in the calculated PC-BOSS $\text{PM}_{2.5}$ mass of $\pm 2.9 \mu\text{g}/\text{m}^3$.

The FDMS and PC-BOSS determined $\text{PM}_{2.5}$ mass results are compared in Table 4.1 and Figure 4.6. Included in Figure 4.6 are four data points (given as open squares) for which the differences between the two measurements were different from the rest of the data set by greater than 3σ . These four data points are not included in the statistical analysis summarized in Table 4.1. The four data points were obtained in four 3-h sequential samples, beginning at midnight on July 23. As indicated by the data in Figure 4.2A, the FDMS and differential TEOM data were in good agreement during this time period. However, the carbon measurements made with the PC-BOSS and the Sunset monitors were also in good agreement. R&P nitrate measurements were not made during this time period. However, the eight 3-h nitrate concentrations determined with the PC-BOSS for the entire day and the results of the SCAQMD 24-h results from the speciation sampler this day are in agreement. Thus, there is nothing in the data set which allows one to ascertain which of the two measurements (PC-BOSS vs the FDMS) is the more accurate.

For the data points included in the statistical analysis, the PC-BOSS and FDMS data are in good agreement with a regression slope ($N = 33$, $R^2 = 0.90$) of 0.96 and $\sigma = \pm 3.0 \mu\text{g}/\text{m}^3$ ($\pm 7.7\%$), with a bias between the two measurements of only $1.8 \mu\text{g}/\text{m}^3$.

Figure 4.6. Comparison of 3-h average $PM_{2.5}$ mass determined with the PC-BOSS and FDMS in Rubidoux, CA. The solid line is the regression slope with a zero intercept and the dashed line is the regression line with a calculated intercept. The four data points where the difference between the two measurements is greater than 3σ compared to the remaining data are indicated with a square data point, see text.

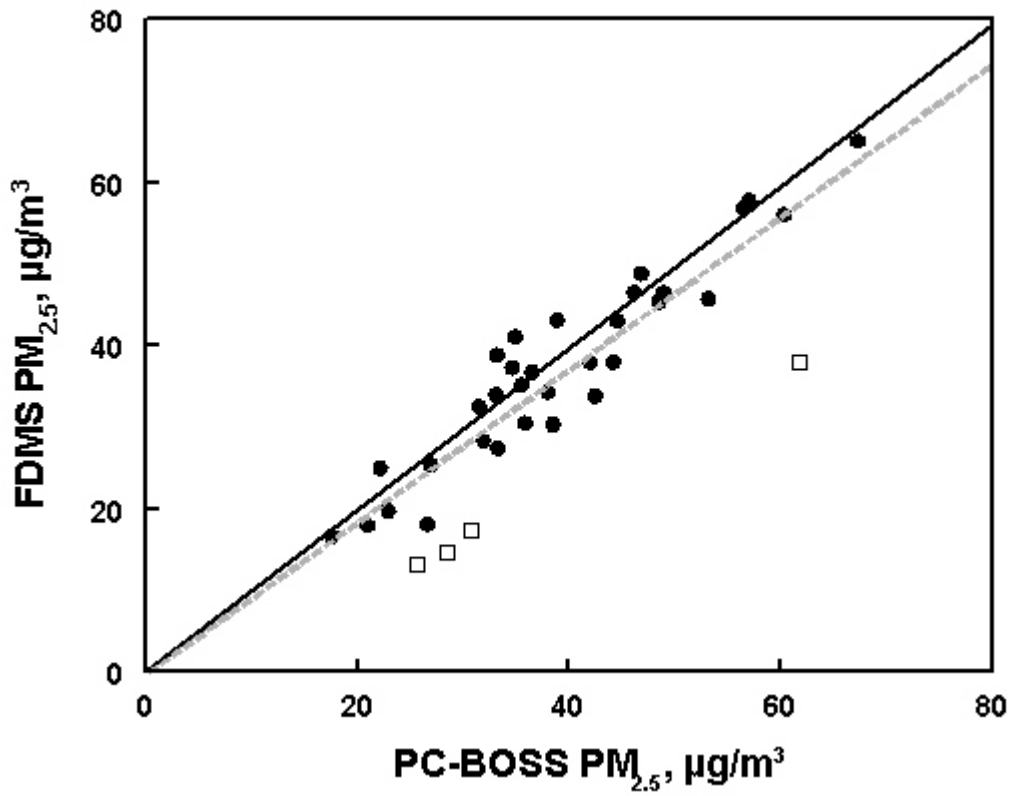

Included in the analysis are four time periods (12:00 - 15:00 and 15:00 - 18:00 on July 11 and July 23) when PC-BOSS, FDMS, and differential TEOM data were all available and there was a significant bias between the FDMS and differential TEOM during peak concentrations, with the FDMS averaging $9.0 \mu\text{g}/\text{m}^3$ higher than the differential TEOM monitor. These time periods include five of the thirty-eight peak concentrations not included in the FDMS vs differential TEOM comparison as previously discussed. The PC-BOSS and FDMS measurements agreed during this time period, with a bias of only $0.3 \mu\text{g}/\text{m}^3$, providing an indication that the occasional significant difference seen between the FDMS and the differential TEOM monitor cannot be attributed to systematically inaccurate measurements by the FDMS. This point deserves further study.

The measurements made with the FDMS can also be compared with the 24-h average mass measurements obtained with the $\text{PM}_{2.5}$ single filter FRM monitor. The comparison between these two measurements is given in Table 4.1 and Figure 4.7. As indicated, there is a consistent bias between the two measurements ($N = 29$), with the FRM averaging $11.3 \mu\text{g}/\text{m}^3$ (32%) lower than the FDMS measurements. While data coverage for the study period was not complete for the speciation data, for the time periods associated with these comparisons, the average concentrations were $12 \mu\text{g}/\text{m}^3$ and $13 \mu\text{g}/\text{m}^3$ of ammonium nitrate and SVOM, respectively. Thus, some combination of partial loss of ammonium nitrate and SVOM during sampling with the single filter FRM can account for the under-measurement of $\text{PM}_{2.5}$ mass measured with this sampler.

The average difference between the FDMS $\text{PM}_{2.5}$ mass measurement and that of a conventional TEOM monitor operating with the filter at 50°C is shown in Figure 4.2C. The conventional TEOM monitor measured mass is consistently lower than the FDMS

Figure 4.7. Comparison of 24-h average $PM_{2.5}$ mass determined with the FDMS and the single filter $PM_{2.5}$ FRM sampler in Rubidoux, CA. The solid line is the slope =1.

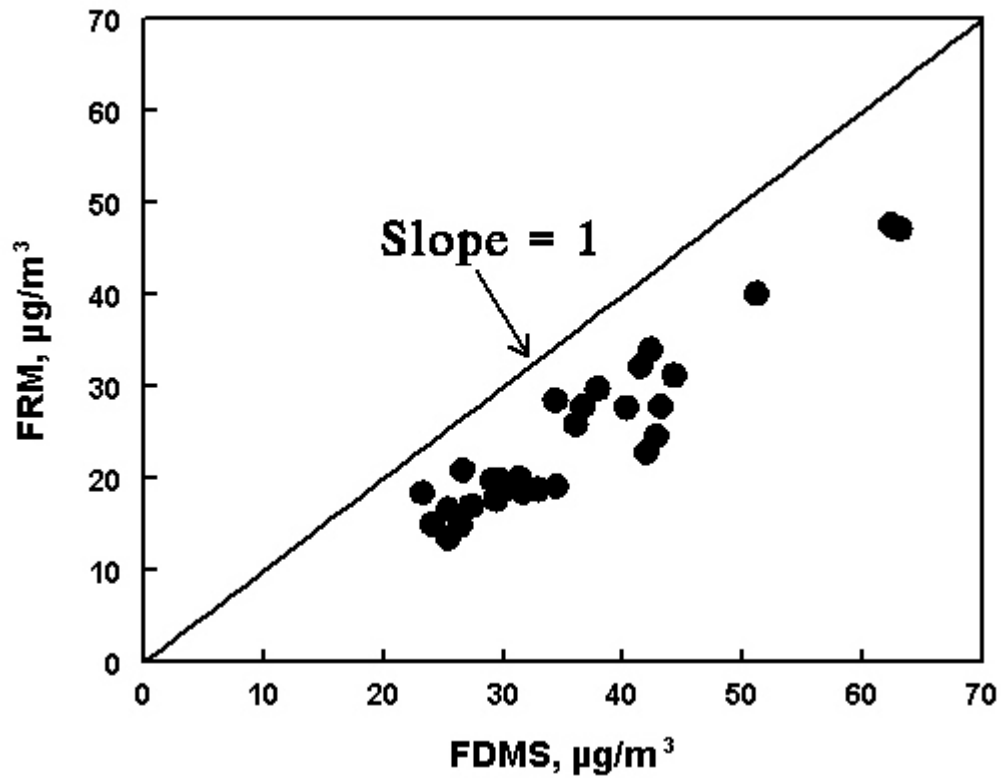

measured mass. Where both measurements were made, the FDMS data averaged 36.8 $\mu\text{g}/\text{m}^3$ and the heated TEOM monitored averaged 18.4 $\mu\text{g}/\text{m}^3$. The bias between the two measurements averaged 18.5 $\mu\text{g}/\text{m}^3$ (50 % of the FDMS $\text{PM}_{2.5}$ mass). The difference between the two measurements can be directly compared with the hourly average measurements of ammonium nitrate by the R&P nitrate monitor and SVOM by the modified Sunset C monitor. The comparison with the ammonium nitrate data is shown in Figure 4.8 for the time period when all three measurements (FDMS, heated TEOM and R&P nitrate, expressed as ammonium nitrate) were monitored. As indicated, the difference between the FDMS and heated TEOM monitors is usually greater than the measured ammonium nitrate concentration. Part, but not all of the difference between the FDMS and heated TEOM monitor $\text{PM}_{2.5}$ mass measurements can be attributed to the loss of ammonium nitrate from the 50 °C filter of the heated TEOM monitor. During part of the time period given in Figure 4.9, both ammonium nitrate and SVOM measurements were made. The sum of these two measurements is referred to as semi-volatile material, SVM, and is compared to the difference in the FDMS and heated TEOM monitor $\text{PM}_{2.5}$ mass in Figure 4.9. With few exceptions, the total SVM material is either equal to or somewhat greater than the difference between the FDMS and heated TEOM monitors. It appears that most of the SVM is generally lost from the heated filter of the TEOM monitor on an hourly average measurement basis.

4.6. Summary

The data obtained in the Lindon and Rubidoux studies indicate that the FDMS, differential TEOM, and GRIMM monitors all measure total $\text{PM}_{2.5}$, including the SVM. In contrast, neither the conventional heated TEOM monitor, the heated GRIMM monitor

Figure 4.8. Data from the Rubidoux July 2003 study. The circles indicate 1-h average FDMS PM_{2.5} mass, the squares the difference between 1-h average FDMS and 50 °C TEOM monitor PM_{2.5} mass, and the bars 1-h average R&P PM_{2.5} ammonium nitrate mass measurements.

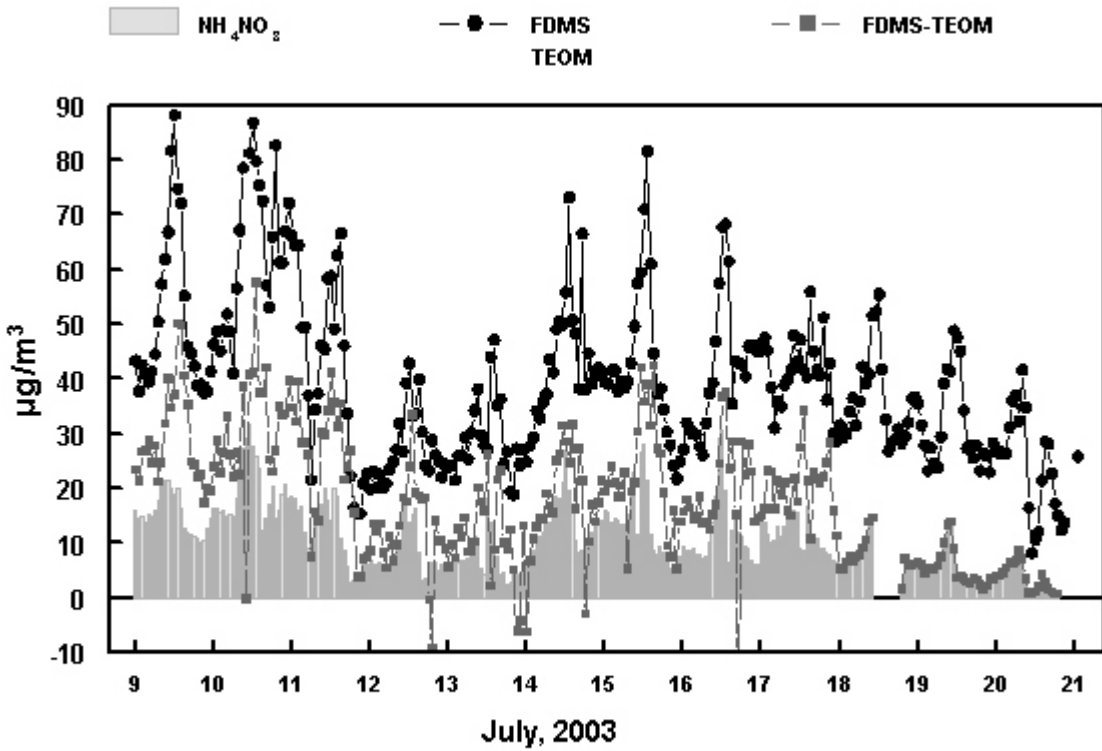
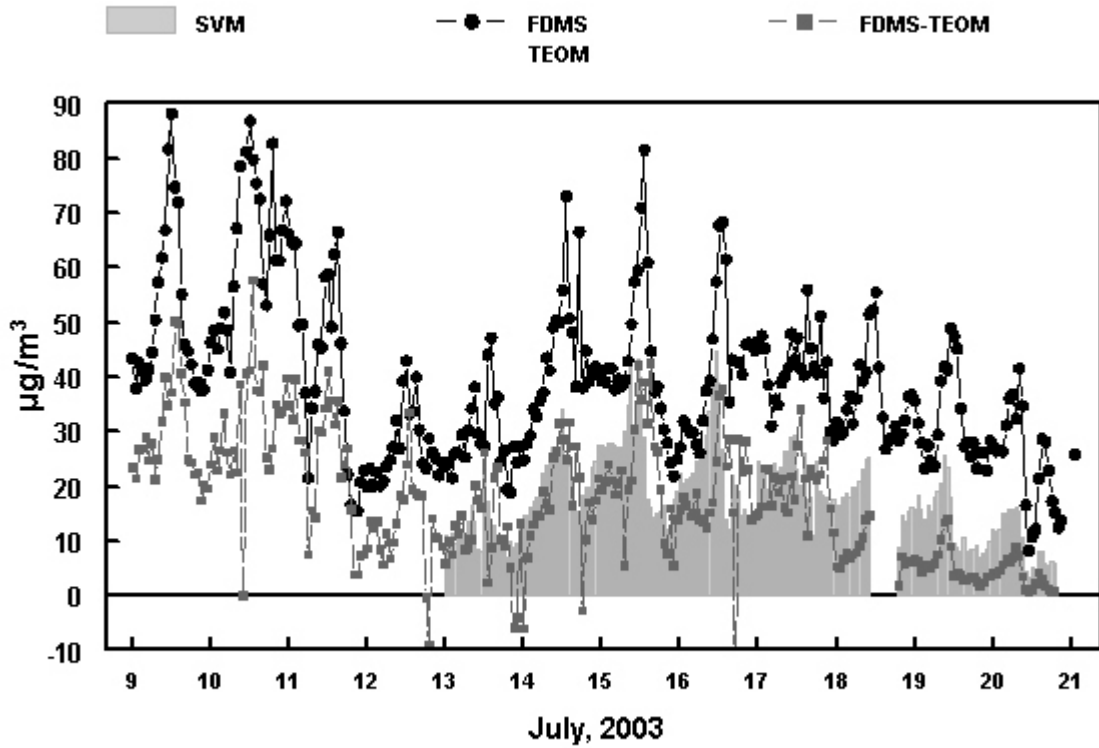

Figure 4.9. Data from the Rubidoux July 2003 study. The circles indicate 1-h average FDMS PM_{2.5} mass, the squares the difference between 1-h average FDMS and 50 °C TEOM monitor PM_{2.5} mass, and the bars the sum of 1-h average R&P PM_{2.5} ammonium nitrate mass measurements and the modified Sunset monitor semi-volatile organic material (SVOM) mass measurements. This sum is indicated as SVM, semi-volatile material.



or the PM_{2.5} FRM single filter sampler measured the SVM. Semi-volatile particulate matter includes both the ammonium nitrate and SVOM. The RAMS, FDMS, and differential TEOM monitors do not measure fine particulate water content because of the use of Nafion dryers. However, the conventional GRIMM monitor may respond to particle bound water under conditions of high %RH. Precision of the comparison of the R&P FDMS and differential TEOM monitor sampler PM_{2.5} is $\pm 11\%$ ($\pm 3.8 \mu\text{g}/\text{m}^3$). Precision of the comparison of the FDMS and PC-BOSS PM_{2.5} mass is $\pm 7.7\%$ ($\pm 3.0 \mu\text{g}/\text{m}^3$). There is a suggestion in the data that the results obtained with the FDMS unit may be biased about 1 to 2 $\mu\text{g}/\text{m}^3$ higher than the differential TEOM monitor for the urban environments studied here. Agreement with the RAMS and PC-BOSS monitor may be slightly better for the FDMS than the differential TEOM monitor, however, the comparisons are all generally within the uncertainty of the RAMS and PC-BOSS data. The precision of both the FDMS and differential TEOM monitors was a factor of 2 to 4 better than that for the RAMS. The FDMS, differential TEOM, and GRIMM monitors proved to be rugged units which needed little attention from site operators during the studies reported here.

4.7. References

Ding, Y., Pang, Y., and Eatough, D.J., (2001). High volume diffusion denuder sampler for the routine monitoring of fine particulate matter: I. Design and optimization of the PC-BOSS, *Aerosol Sci. Technol.*, 36: 369-382.

Eatough, D.J., Long, R.W., Modey, W.K., and Eatough, N.L., (2003). Semi-volatile secondary organic aerosol in urban atmospheres: meeting a measurement challenge, *Atmospheric Environ.*, 37: 1277-1292.

Eatough, D.J., Eatough, N.L., Obeidi, F., Pang, Y., Modey, W., and Long, R. (2000). Continuous determination of PM_{2.5} mass, including semi-volatile species, *Aerosol Sci. Technol.*, 34: 1-8.

- Ellis, E.C. and Novakov, T. (1982). Application of thermal analysis to the characterization of organic aerosol particles, *Sci. Total Environ.*, 23: 227-238.
- Grover, B. D., Kleinman, M., Eatough, N.L., Eatough, D.J., Cary, R.A., Hopke, P.K., Smith, D., and Wilson W.E. (2004). Measurement of PM_{2.5} nonvolatile and semi-volatile organic material with the sunset laboratory carbon aerosol monitor, paper presented at the AWMA 97th Annual Conference and Exhibition, Indianapolis, Indiana, June 22-25.
- Lewtas, J., Booth, D., Pang, Y., Reimer, S., Eatough, D.J., and Gundel L. (2001). Comparison of sampling methods for semi-volatile organic carbon (SVOC) associated with PM_{2.5}, *Aerosol Sci. Technol.* 34: 9-22.
- Long, R.W., Eatough, N.L., Mangelson, N.F., Thompson, W., Fiet, K., Smith, S., Smith, R., Eatough, D.J., Pope, C.A., and Wilson, W.E. (2003). The measurement of PM_{2.5}, including semi-volatile components, in the EMPACT program: Results from the Salt Lake City study and implications for public awareness, health effects, and control strategies, *Atmospheric Environ.*, 37, 4407-4417, 2003.
- Long, R.L. and McClenny, W.A., Laboratory and field evaluation of instrumentation for the semi-continuous determination of particulate nitrate (and other water soluble particulate components), paper presented at the AWMA 97th Annual Conference and Exhibition, Indianapolis, Indiana, June 22-25, 2004.
- Meyer, M.B., Patashnick, H., and Ambs, J.L. (2002). Ongoing development of a continuous reference standard particulate matter mass monitor for ambient air, paper presented at the Symposium on Air Quality Measurement Methods and Technology, San Francisco, CA, November.
- Mignacca, D. and Stubbs, K. (1999). Effects of equilibration temperature on PM₁₀ concentrations from the TEOM method in the Lower Fraser Valley, *J. of Air & Waste Manage. Assoc.*, 49, 1250-1254.
- Patashnick, H., Rupprecht, G., Ambs, J.L., and Meyer, M.B., Development of a reference standard for particulate matter mass in ambient air, *Aerosol Sci. and Technol.*, 34, 42-45, 2001.
- Patashnick, H. and Rupprecht, E.G. (1991). Continuous PM₁₀ measurements using the tapered element oscillating microbalance, *J. of Air & Waste Manage. Assoc.*, 41: 1079-1083.
- Sioutas, C., Koutrakis, P., and Burton, R.M., (1994). Development and evaluation of a low cutpoint virtual impactor, *Aerosol Sci. Technol.*, 21: 223-235.

Tang, H., Lewis, E.A., Eatough, D.J., Burton, R.M., and Farber, R.J. (1994). Determination of the particle size distribution and chemical composition of semi-volatile organic compounds in atmospheric fine particles, *Atmospheric Environ.*, 28: 939-947.

Turpin, B.J. and Lim, H.J. (2001). Species contributions to PM_{2.5} mass concentrations: Revisiting common assumptions for estimating organic mass, *Aerosol Sci. Technol.*, 35: 602-610.

Turpin, B.J. and Huntzicker, J.J. (1994). Investigation of organic aerosol sampling artifacts in the Los Angeles basin, *Atmospheric Environ.*, 28: 3061-3071.

Yi, S.-M., Ambs, J.L., Patashnick, H., Rupprecht, G., Hopke, P.K. (2004). Evaluation of a prototype electrostatic precipitator (ESP) for a differential TEOM system, *Aerosol Sci Technol.*, submitted.

Chapter 5. Source Apportionment of 1-h Semi-Continuous Data Using Positive Matrix Factorization with Total Mass (Nonvolatile plus Semi-Volatile) Measured by the R&P FDMS Monitor

5.1. Overview

Human health endpoints associated with exposure to airborne particulate matter (PM) include increased mortality and morbidity from respiratory and cardiopulmonary disease (Pope, 2000; Schwartz *et al.*, 1996). These effects are observed with exposure to concentrations substantially below the U.S. PM₁₀ (particulate matter with aerodynamic diameter less than 10 μm) ambient air quality standard. The exacerbation of observed health problems is believed to be associated more closely with exposure to fine particles (PM_{2.5}, particulate matter with aerodynamic diameter less than 2.5 μm), especially those generated by combustion, than exposure to coarse particles. As a result, the U.S. Environmental Protection Agency has promulgated revised standards for PM, which establishes new annual and 24-h PM_{2.5} standards. The EPA's decision to revise the PM National Ambient Air Quality Standards (NAAQS) has sparked renewed interest in the ability to accurately measure fine PM and to improve source characterization methods. Identification of the sources of fine particles responsible for the epidemiologically identified health effects would significantly aid in the implementation of the new PM_{2.5} standard (Thurston *et al.*, 2005; Mar *et al.*, 2005).

Source receptor models have commonly been used to deduce source contributions to measured PM_{2.5} mass (Zheng *et al.*, 2004; Eatough *et al.*, submitted; Kim, *et al.*, 2003). A recently developed positive matrix factorization program, PMF2, allows for source determination using a least squares approach to solve the factor analysis problem.

Solutions are forced to be nonnegative and estimates in the measurement error are used as weighting parameters for individual data points. A linear combination of a source matrix and an error estimate matrix is employed.

Semi-continuous monitoring data have been shown to greatly improve the power of receptor models to determine sources (Grover *et al.*, In press). In this study, PMF2 was used to deduce source contributions from a major sampling campaign conducted in Rubidoux, CA during July 2003. This chapter discusses the application of PMF2 to semi-continuous 1-h averaged data, the PMF2 results obtained, and the interpretation of the resulting factor profiles and contributions.

5.2. Receptor Model Analysis

PMF2 and the algorithm used in the analysis has been previously described (Paatero, 1997) and was outlined in Chapter 2. One of the unique advantages to PMF is the ability to account for missing and below detection limit data. The uncertainty in each measurement can be adjusted to account for aberrations in the data set. In this study, error uncertainty estimates were chosen similar to those previously outlined by Polissar *et al.*, (1998). For what were determined to be “reliable” data, the concentration values were directly used and the error estimates were assigned as the measurement error plus one third the limit of detection (LOD). In a few instances when the measurement was below the LOD, the concentration values were set to one half the LOD and the error was estimated as 5/6 the LOD. Missing values in the data set were accounted for by taking the geometric mean of the hour preceding and following the missing data point. The error estimates were then set to 4 times the geometric mean value. Following periods of high concentrations of SVM, TEOM mass measurements can be negative due to

excessive loss of SVM off the collection filter (Mignacca and Stubbs 1999; Eatough *et al.*, 2003). For these time periods, the negative concentration value was retained and the error estimate was set to four times the absolute value of the negative mass measurement. In this study, SVM concentrations were obtained by the difference between the FDMS and the conventional TEOM mass measurements. Therefore, the error estimate was performed as mentioned above using the highest LOD of the two measurement techniques. For time periods when SVM concentrations were negative, the negative concentration was used and the error estimate was set to four times the absolute value of the negative concentration.

5.3. Data Collection and Analysis

Data collection was conducted at the South Coast Air Quality Monitoring District (SCAQMD) sampling site in Rubidoux, CA during July, 2003 and has been extensively described in Chapter 4 (Grover *et al.*, 2005). Rubidoux is located at the eastern end of the Los Angeles basin. $PM_{2.5}$ originating from the Los Angeles and other urban areas in the South Coast Basin are transported across the basin during periods of high photochemical activity. Also stable inversions were frequent during the sampling period, resulting in high concentrations of secondary particulate organic material (OM) and nitrate. Furthermore, several ammonia sources exist near the end of the basin prior to the Rubidoux sampling site abetting the formation of NH_4NO_3 , much of which is semi-volatile in nature. These conditions resulted in a good opportunity to study an urban aerosol with high concentrations of both non-volatile material (NVM) and SVM (Grover *et al.*, 2005).

One-h semi-continuous measurements were made throughout the study period with instruments to measure both $PM_{2.5}$ mass, $PM_{2.5}$ chemical species, and gas phase species with concentrations shown in Figure 5.1. Total $PM_{2.5}$ mass, including nonvolatile and semi-volatile mass, was measured using a R&P FDMS TEOM monitor. Recent studies indicate that the FDMS monitor accurately measures total $PM_{2.5}$ mass (Grover *et al.*, 2005; Grover *et al.*, accepted). A conventional TEOM monitor, operated at 50 °C, was also employed. Because the TX40 filter is heated on the conventional TEOM monitor, this technique only measures nonvolatile mass (Mignacca and Stubbs 1999; Long *et al.*, 2002; Long *et al.*, 2003; Eatough *et al.*, 2003; Grover *et al.*, 2005). A R&P 5400 Carbon monitor was used to measure atmospheric carbonaceous material concentrations, which measures organic carbon (OC), EC and total carbon (TC). Due to missing data and problems associated with the instrument during sampling, only TC data were used in the PMF analysis. EC concentrations were measured by an Anderson Aethalometer. The Aethalometer also provided an absorption measurement at 350 nm, referred to as UV, which has been shown to be a good marker for diesel emissions (Hansen *et al.*, 2002). Nitrate concentrations were monitored with a R&P 8400N nitrate monitor. Due to excess ammonia in the Riverside area, nitrate was assumed to be present as NH_4NO_3 . Because the FDMS monitor measures total $PM_{2.5}$ concentrations and the TEOM monitor measures only non-volatile $PM_{2.5}$ concentrations, SVM concentrations can be determined as the R&P FDMS measurement minus the R&P TEOM monitor concentrations. Gas phase data including, carbon monoxide (CO), ozone (O_3), nitrogen dioxide (NO_2), and nitrogen oxides ($NO + NO_2 = NO_x$), were measured by the SCAQMD at the Rubidoux, CA site.

Figure 5.1. Semi-continuous monitor data including measurements of PM_{2.5} mass, chemical species, and gas phase species.

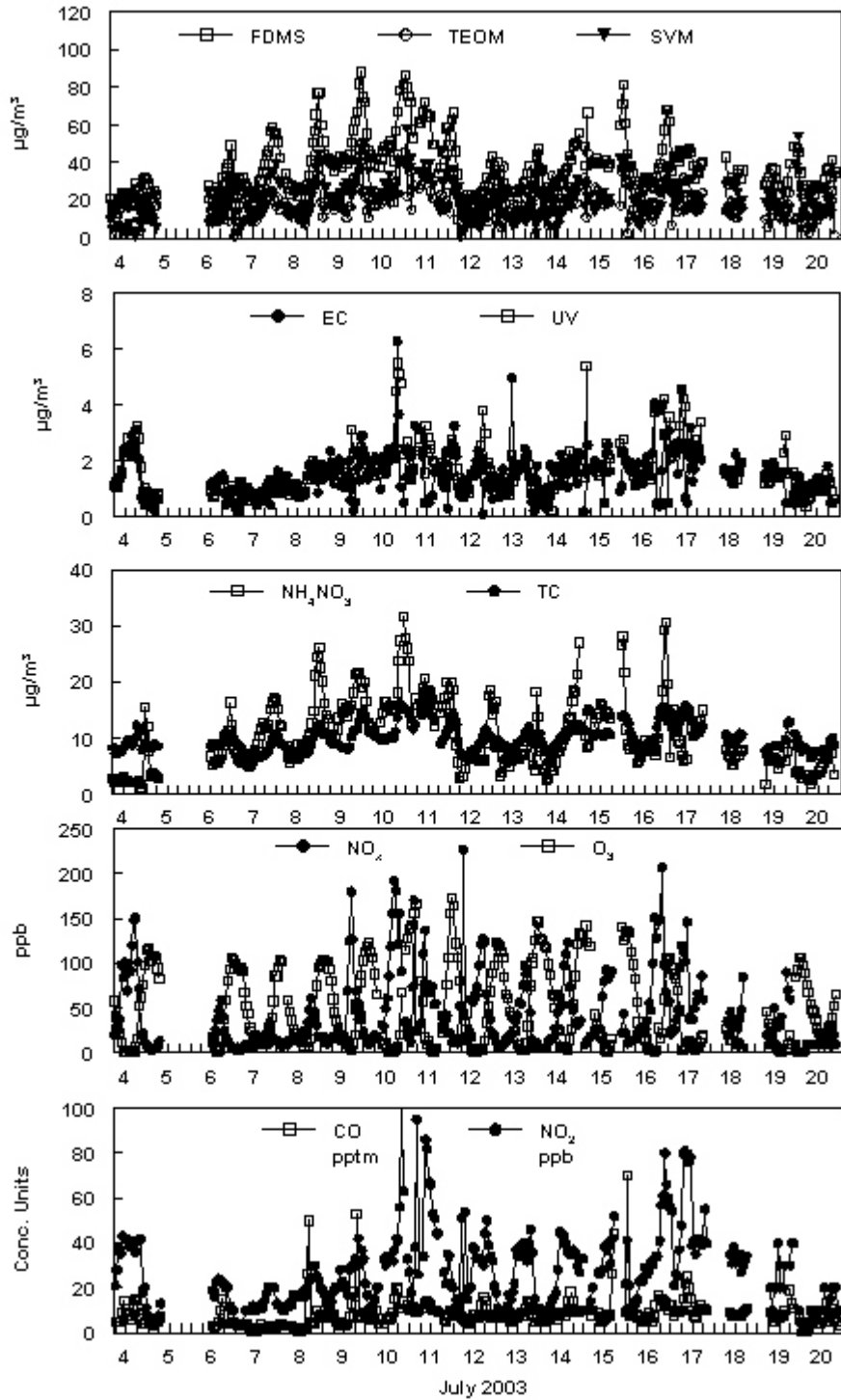

5.4. Results

In performing PMF, the number of factors to be identified is defined by the user. However, a higher order solution does not necessarily contain the same factors as a lower order solution. Experimentation with the number of factors is performed until the most reasonable results are obtained (i.e., the results describe the data and are meaningful). In this study, the robust mode (Paatero, 1997) was used in which data were down weighted if the standard deviation was greater than four times the error estimate.

Eleven species were used in the study and six factors were identified. A twelfth species, NO, was available but did not provide any atmospheric relevance and actually hindered the identification of factors. Therefore, adding species to the analysis that do not provide useful information in the identification of factors does not necessarily assist the power of the analysis to define factors. The time period from the evening of July 4 through July 5 was intentionally removed from the analysis due to a fourth of July fireworks display and resulting fire near the sampling site (Grover *et al.*, 2005).

Rotational ambiguity, which can plague this type of factor analysis, can be restrained by applying an FPEAK value. In this case, an FPEAK value of zero resulted in the most meaningful results. An evaluation of the quality of the fitted data can be obtained by comparing the degrees of freedom (i.e., the number of data points) with the calculated value of Q . If a reasonable fit is obtained, the calculated value of Q should be approximately equal to the degrees of freedom. Deviation from the theoretical value suggests that the errors in the model are not well defined. For this study, the number of degrees of freedom was 3586 and the resultant Q value was 1604. A second check on the “fit” of the solution can be made by comparing the sum of the factor contributions to the

measured mass, to verify that the measured mass is well defined by the calculated sources. In this case, the sum of the factor contributions was in excellent agreement with the measured $PM_{2.5}$ mass as shown in Figure 5.2. Linear regression analysis resulted in a zero intercept slope of 0.99 ± 0.00 ($R^2 = 0.99$, $n = 326$) and a calculated slope of 0.97 ± 0.00 ($R^2 = 0.99$ and $b = 0.90 \pm 0.99$).

Source profiles for the six identified factors are shown in Figure 5.3. Table 5.1 identifies the specific chemical species contributions of the identified factors. In source apportionment, an a priori knowledge of chemical markers, that can be attributed to a particular source, is needed to identify sources most likely associated with each factor. Relevant time patterns were also used in this study to aid in the identification of the sources. The sources identified during this study suggest that the Rubidoux area was impacted by both local emissions and secondary transport mechanisms during the study period. During the summertime, pollution that originates in the Los Angeles area is often transported by coastal winds across the basin to Riverside County (Grover *et al.*, 2005).

Factor 1 was dominated by SVM. The majority of the NH_4NO_3 , a semi-volatile species, measured during this study was also attributed to factor 1. Furthermore, this factor contained a large fraction of NO_2 , a precursor to nitrate formation. Time patterns show increased concentrations during mid-day time periods as shown in Figure 5.4. A similar time pattern is observed in NH_4NO_3 concentrations observed during the study as shown in Figure 5.1. HYSPLIT generated back trajectories (NOAA 2002) during the study time period indicated that ground level air was dominated by coastal winds from the Los Angeles area to the Rubidoux sampling site. These coastal winds were most dominant during mid-day to afternoon time periods when $PM_{2.5}$ concentrations were the

Figure 5.2. Comparison of PM_{2.5} total mass (nonvolatile plus semi-volatile) measured by the FDMS and the PM_{2.5} predicted mass by PMF2.

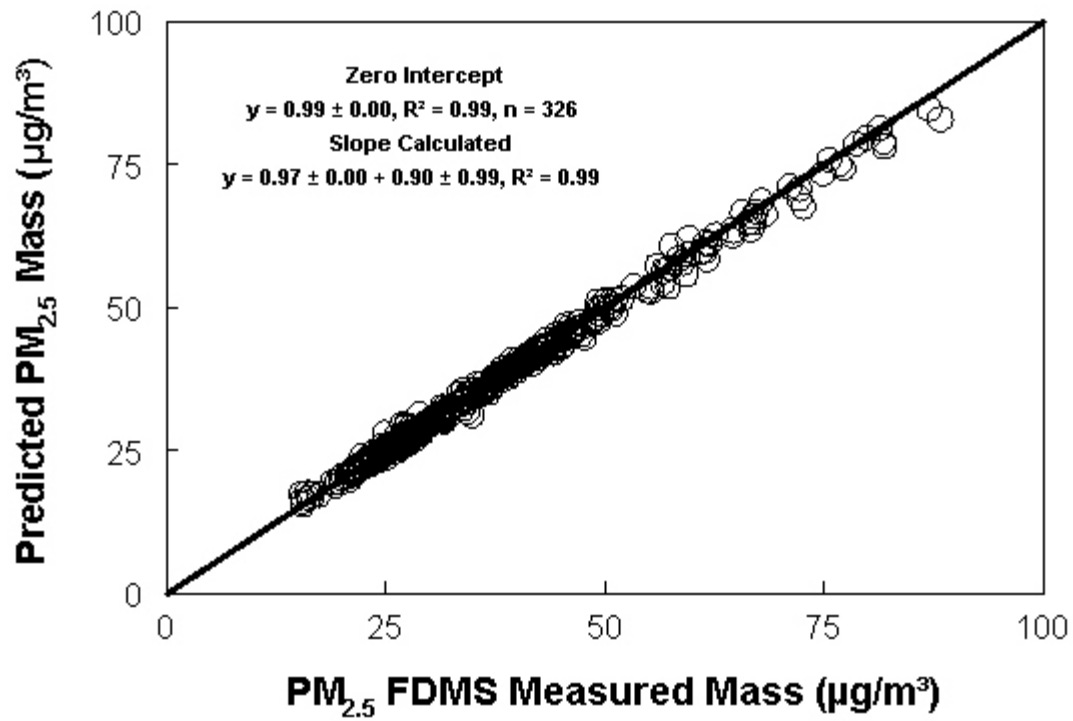

Figure 5.3. Source profiles deduced by PMF2 from the semi-continuous monitoring data collected during July 2003 in Rudidoux, CA. Percent of FDMS concentrations are given on the right y-axis for the particulate species and gas-phase species contributions are given on the left y axis.

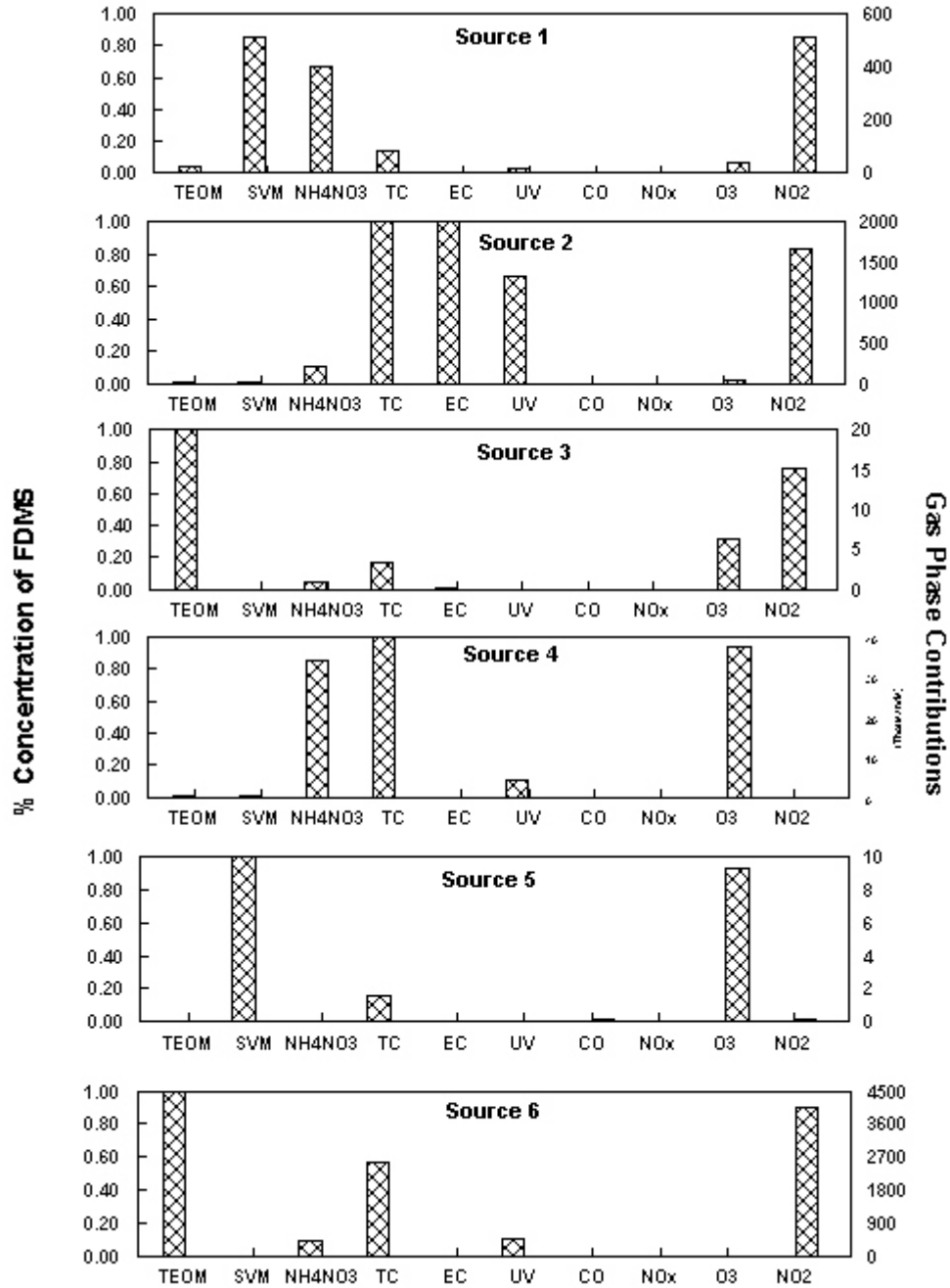
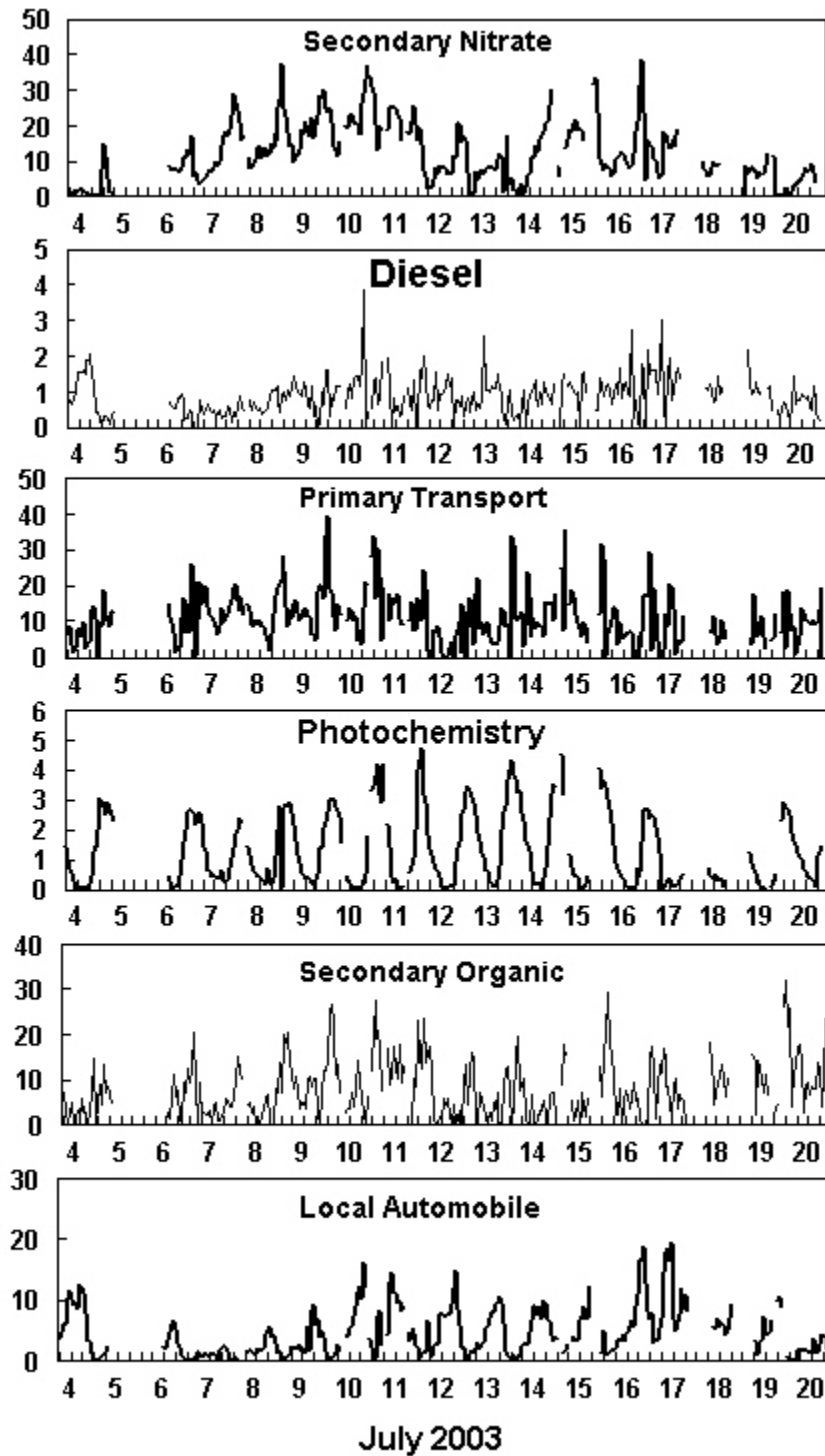

Table 5.1. Source Concentration Profiles for the Six Identified Sources with the Contribution of the Respective Chemical Species to the Source Mass.

Source	µg TEOM per µg FDMS	µg SVM per µg FDMS	µg NH₄NO₃ per µg FDMS	µg TC per µg FDMS	µg EC per µg FDMS	UV Units per µg FDMS	pptm CO per µg FDMS	ppb NO_x per µg FDMS	ppb O₃ per µg FDMS	ppb NO₂ per µg FDMS
Sec. Nitrate (Source 1)	0.5	10.3	8.1	1.7	0.1	0.3	0.0	5.7	0.5	6.3
Local Diesel (Source 2)	0.0	0.0	0.1	1.2	1.4	0.6	0.9	0.0	0.0	1.5
Primary Transport (Source 3)	12.9	0.0	0.5	1.9	0.1	0.0	0.0	0.0	0.0	0.2
Local Photochemistry (Source 4)	0.0	0.0	1.1	1.5	0.0	0.1	1.6	0.0	49.3	0.0
Sec. Organic (Source 5)	0.0	8.8	0.0	1.2	0.0	0.0	0.7	0.1	0.0	0.0
Local Auto (Source 6)	5.0	0.0	0.4	2.6	0.0	0.5	4.0	29.5	0.0	18.7

Figure 5.4. Source contributions from the six sources obtained at the SCAQMD Rubidoux, CA sampling site.



highest. Nitric acid is formed by the reaction of NO_2 with the OH radical during periods of high photochemical activity and then transported by coastal winds across the Los Angeles basin. Excess ammonia in the region reacts with nitric acid to form NH_4NO_3 . Factor 1 was therefore identified as a secondary nitrate source. A weekday-weekend pattern is observed in source 1 and NH_4NO_3 data, with decreased concentrations observed during weekend time periods. As expected, NO_2 emissions are more intense during the week, propagating the formation of nitric acid and subsequent formation of NH_4NO_3 in the Rubidoux area. This source was a major contributor to the total $\text{PM}_{2.5}$ mass during the study, accounting for 32% of the total mass.

Factor 2 was dominated by local diesel emissions and accounted for 2% of the local aerosol mass. Diesel emissions are rich in EC concentrations. The majority of the EC and UV measured by the Aethalometer was attributed to this source (Table 5.1). Both EC and UV have been shown to be good markers for diesel emissions (Hansen *et al.*, 2002). The time patterns observed in Source 2 correlate well with local diesel traffic patterns (Figure 5.4). Diesel emissions were observed throughout the daytime sampling periods and did not exhibit a discernable daily diurnal pattern. Heavy-duty diesel trucks are not constrained to rush-hour time periods and tend to be on the road during most daytime periods. Furthermore, higher concentrations were observed during weekday time periods compared with weekend time periods, as would be expected.

Factor 3 displayed increased concentrations during daytime periods and exhibited peak concentrations similar to those observed with the secondary nitrate source (Figure 5.4). Furthermore, factor 3 contained almost all the primary mass measured by the TEOM monitor (Table 5.1) and accounted for 29% of the observed aerosol mass during

the study. Because the identified time pattern of factor 3 correlates well with the transport of $PM_{2.5}$ across the basin, the dominant source associated with this factor was identified as primary transported mass, i.e. $PM_{2.5}$ that is transported by coastal winds but is nonvolatile in nature. Several stable aerosol species exist that would be expected to be transported with coastal winds including, ammonium sulfate, non-volatile organic species and crustal elements.

The formation of tropospheric O_3 is considered to be a secondary process due to photochemical reactions that promote the formation of O_3 . Peak concentrations of O_3 were observed during mid-day time periods (Figure 5.1) during this study when photochemical activity was the highest. Many complex reactions involving volatile organic species (VOCs) and NO_x also contribute to the formation of O_3 . Consequently, O_3 concentrations are geographically variable. Local O_3 concentrations would therefore be expected to correspond with local photochemical activity but would not be expected to correlate well with secondary pollutants that resulted from transport mechanisms. Essentially all of the O_3 observed during the study was attributed to factor 4 by the PMF analysis (Table 5.1). Time patterns correspond well with local O_3 concentrations, with peak concentration periods observed during mid-day time periods (Figure 5.4). Factor 4 can therefore be attributed to local photochemical formation of secondary species in the aerosol and is labeled a local photochemistry source. However, most of the SVM observed at the Rubidoux site was not attributed to local secondary formation but was due to transport of the aerosol across the Los Angeles basin under conditions of high photochemical activity. Local photochemical formation of secondary species only accounted for 3% of the local aerosol mass.

SVM consists of both NH_4NO_3 and low molecular weight organic species, the majority of which are secondary (Eatough *et al.*, 2003). Reaction pathways for the formation of secondary organic aerosols are not well understood but are thought to be initiated by O_3 and the OH radical. Increased concentrations of secondary organic species in the Los Angeles basin have been observed during high O_3 concentration episodes (Turpin and Hunzickler 1995; Turpin *et al.*, 1991). PMF2 was able to separate semi-volatile nitrate and semi-volatile organic material (SVOM) into two separate factors in this study. Factor 5 contained a large fraction of the SVM but no NH_4NO_3 (Table 5.1). Time patterns for factor 5 are consistent with other sources attributed to transport mechanisms during this study with mid-day peaks observed (Figure 5.4). Factor 5 was therefore defined as a secondary organic source dominated by formation during transport across the Los Angeles basin. Also, higher concentrations were observed during weekday periods compared to weekend time periods as observed with other transport sources. Source 5 accounted for 21% of the local aerosol mass.

Rubidoux is often impacted by weekday morning rush-hour traffic as commuters head toward the Los Angeles area. NO_2 and CO have been shown to be good markers of automobile emissions (Long *et al.*, 2002; Grover *et al.*, in press). Factor 6 contained a large fraction of the CO, NO_2 and NO_x (Table 5.1) and therefore was defined as a local automobile emission source accounting for 12% of the local aerosol mass. Furthermore, this factor exhibits peak concentrations during early morning rush-hour time periods (Figure 5.4).

5.5. Discussion and Conclusions

Although PMF2 was able to identify six factors that could be related to both primary and secondary sources in Rubidoux during the study period, it is not reasonable to assume that all sources were identified. The factors determined by PMF2 do not contain all emission sources in the region. However, the dominant or major sources of PM_{2.5} in Rubidoux during the sampling period were identified as factors in the PMF2 analysis, and the source contributions explained the total PM_{2.5} mass measured by the FDMS monitor.

The impact of regional pollution is evident in this study. Eighty-two percent of the local aerosol mass measured at the Rubidoux, CA site was attributed to PM_{2.5} that was transported across the Los Angeles Basin, including semi-volatile secondary species and nonvolatile species. Impacts from local emissions were generally small (18% of the total mass) and were dominated by local automobile emissions (12% of the total mass).

The advantage of using semi-continuous sampler data in the application of source apportionment is evident in this study. Local aerosols are often impacted by short-term pollution episodes that cannot be temporally resolved using integrated samplers. One-h averaged data applied to source apportionment models may increase the power of the model to predict sources that exhibit diurnal short-term episodes. Furthermore, using only 11 species we were able to identify 6 sources over a short study time period. The application of instruments to measure semi-volatile species allowed for the identification of secondary sources. In this study, these secondary sources were related to transport mechanisms under conditions of high photochemical activity and local secondary

formation processes. However, local secondary formation processes did not contribute substantially to PM_{2.5} mass.

5.6. References

Eatough, D.J., Long, R.W., Modey, W.K., Eatough, N.L. (2003). Semi-Volatile Secondary Organic Aerosol in Urban Atmospheres: Meeting a Measurement Challenge. *Atmos. Environ.* 37: 1277-1292.

Eatough, D. J., Anderson, R. A, Martello, D. V., Modey, W. K., Davidson, C. L., Pekney, N. J., Mangelson, N. F. Apportionment of Ambient Primary and Secondary PM_{2.5} During a 2001 Summer Intensive Study at the CMU Supersite and NETL Pittsburgh Site Using PMF2. *J. of Air & Waste Manage. Assoc.* Submitted.

Grover, B. D, Carter, C. B. Kleinman, M. A., Richards, J. S., Eatough, N. L. and Eatough, D. J. Monitoring and Source Apportionment of Fine Particulate Matter at Lindon, Utah. *Aerosol Sci. Technol.* In Press.

Grover, B .D., Kleinman, M. A., Eatough, N. L., Eatough, D. J., Hopke, P. K., Long, R. W., Wilson, W. E., Meyer, M. B., Ambs, J. L. (2005) Measurement of Total PM_{2.5} Mass (Nonvolatile plus Semi-Volatile) with the FDMS TEOM Monitor. *J. Geophysical Research.* 110, D07S03.

Hansen, A.D.A (2002). *The Aethalometer Operating Manual*, http://www.mageesci.com/Aethalometer_book_2002.06.5.pdf, accessed September 16, 2002.

Kim, E, Hopke, P. K., Edgerton, E. S. (2003). Source Identification of Atlanta Aerosol by Positive Matrix Factorization. *J. of Air & Waste Manage. Assoc.* 53: 731-739.

Long, R.W., Smith, R., Smith, S., Eatough, N.L., Mangelson and Eatough, D.J. (2002) Sources of Fine Particulate Material along the Wasatch Front, *Energy and Fuels.* 16: 282-293

Long, R. W., Eatough, N. L., Mangelson, N. F., Thompson, W., Fiet, K., Smith, S., Smith, R., and Eatough, D. J., (2003). The Measurement of PM_{2.5}, Including Semi-Volatile Components, in the EMPACT Program: Results from the Salt Lake City Study and Implications for Public Awareness, Health Effects, and Control Strategies, *Atmos. Environ.* 37: 4407-4417.

Mar, T.F., Kazuhiko, I., Koenig, J.Q., Larson, T.V., Eatough, D.J., Henry, R.C., Kim, E., Laden, F., Lall, R., Neas, L., Stolzel, M., Paatero, P., Hopke, P.K., Thurston, G.D. (2005). PM source apportionment and health effects. 3. Investigation of inter-method

variations in associations between estimated source contributions of PM_{2.5} and daily mortality in Phoenix, AZ. *J. Exposure Analy. Environ. Epidemiology*. In press.

Mignacca, D., Stubbs, K. (1999) Effects of Equilibration temperature on PM₁₀ Concentrations from the TEOM Method in the Lower Fraser Valley. *J. of Air & Waste Manage. Assoc.* 49: 1250-1254.

NOAA (2002) <http://www.arl.noaa.gov/ready/hysplit4.html>, accessed September 19, 2005.

Paatero, P. (1997) Least squares formulation of robust, non-negative factor analysis. *Chemomet. Intell. Lab. Syst.* 37, 13-35.

Polissar, A. V., Hopke, P. K., Malm, W. C., Sisler, J. F. (1998) Atmospheric aerosol over Alaska 2. Elemental composition and sources. *J. Geophys. Research* 103, 19045-10057.

Pope, C.A. III (2000). Epidemiology of fine particulate air pollution and human health; Biological mechanisms and who's at risk? *Environ. Health Perspect.* 108(Sup 4): 713-723.

Schwartz, J., Dockery, D.W., Neas, L.M., (1996) Is daily mortality associated specifically with fine particles? *J. Air & Waste Manage. Assoc.* 46: 927-939.

Thurston, G.D., Mar, T., Christensen, W.F., Eatough, D.J., Henry, R.C., Kim, E., Laden, F., Hall, R., Larson, T.V., Liu, H., Neas, L., Pinto, J., Stolzel, M., Shuh, H., Hopke, P.K. (2005) The workshop on the source apportionment of PM health effects: Inter-comparison of results and implications. *Environ. Health. Perspect.* In Press.

Turpin, B. J., Huntzicker, J. J., (1995) Identification of secondary organic aerosol episodes and the quantization of primary and secondary aerosol concentrations during SCAQS. *Atmos. Environ.* 29: 3527-3544.

Turpin, B. J., Huntzicker, J. J., Larson, S. M., Cass, G. R. (1991) Los Angeles summer midday particulate carbon: primary and secondary aerosol. *Environ. Sci. Technol.* 25: 1788-1793.

U.S. Environmental Protection Agency. (2002) Air Quality Criteria for Particulate Matter, Environmental Protection Agency, Research Triangle Park, NC, EPA/600/P-99/002aC.

Watson, J. G., Chow, J. C. (2004) Receptor Models for Air Quality Management. *Environ. Management.* 15-23

Zheng, L., Hopke, P. K., Husain, L., Qureshi, S., Dutkiewicz, V. A., Schwab, J. J., Drewnick, F., Demerjian, K. L. (2004) Sources of fine particle composition in New York City. *Atmos. Environ.* 38: 6521-6529.

Chapter 6. Measurement of Both Nonvolatile and Semi-Volatile Fractions of Fine Particulate Matter in Fresno, CA.

6.1. Introduction

Exposure to fine particulate matter ($PM_{2.5}$, particles with an aerodynamic diameter less than 2.5 μm) has been implicated as a contributor to adverse human health effects including increases in cardiovascular and pulmonary disease, which leads to elevated human mortality and morbidity (Pope, 2000; Schwartz *et al.*, 1996; U.S. EPA, 2002). $PM_{2.5}$ has also been associated with visibility degradation in urban (Watson 2002; Eatough *et al.*, 2003) and pristine environments (Eatough *et al.*, 1996) and contributes to changes in the global radiative balance (Chung and Seinfeld, 2002; Conant *et al.*, 2003). The exacerbation of observed health problems is believed to be associated more closely with exposure to fine particles, especially those generated by combustion, than coarse particles. Adverse human health effects have been observed at concentrations substantially below the U.S. PM_{10} national ambient air quality standards (NAAQS). As a result, in 1997 the U.S. Environmental Protection Agency (EPA) promulgated revised standards for PM, which established new annual and 24-h $PM_{2.5}$ NAAQS. The $PM_{2.5}$ Federal Reference Method (FRM), based on the collection of $PM_{2.5}$ on a single filter, is used as the indicator for $PM_{2.5}$ mass measurement compliance in monitoring networks (Musick, 1999; Schaefer *et al.*, 1997). This recognition of fine and coarse particles as different classes of PM was an advancement in the understanding and control of PM (Chow, 1995; Wilson and Shuh, 1997).

Single filter methods, such as the $PM_{2.5}$ FRM, can accurately measure stable species such as sulfate, and trace and crustal elements (Musick, 1999) but cannot

accurately determine semi-volatile fine particulate species such as ammonium nitrate and semi-volatile organic material (Eatough *et al.*, 2003; Hering and Cass, 1995).

Identification of the component(s) of fine particles responsible for the epidemiologically identified health effects would significantly aid implementation of the new $PM_{2.5}$ standard. New research is focusing on the improved characterization of urban $PM_{2.5}$.

Several integrated samplers have been developed that accurately determine nonvolatile material and semi-volatile material (SVM) concentrations including a modified speciation sampler (Carter *et al.*, 2002) and the particle concentrator-Brigham Young University organic sampling system, PC-BOSS, (Tang *et al.*, 1994; Sioutas *et al.*, 1994; Ding *et al.*, 2002a; Modey *et al.*, 2001; 2002; Ding *et al.*, 2002b; Lewtas *et al.*, 2001). Although these samplers can accurately speciate $PM_{2.5}$, including SVM, there are several drawbacks. Integrated samplers are very labor and cost intensive. Collection of filter media and in-lab analysis are time-consuming and expensive, resulting in data interpretation weeks and months from the time of collection. The potential for sample contamination is increased with collection, transport, and laboratory analysis. Furthermore, 1-h time resolved data is often not possible with integrated samplers which inhibits the ability to temporally resolve short term changes in pollution levels that often occur in urban environments.

To overcome these problems, the development of real-time or near real-time instruments has been attempted. One of the most universally used real-time $PM_{2.5}$ measurement techniques is the Tapered Element Oscillating Microbalance (TEOM) developed by Rupprecht & Patashnick. The TEOM does not accurately determine total $PM_{2.5}$ mass because the particle collection filter is heated to 30 - 50 °C to remove particle

bound water which also results in loss of SVM. The real-time total ambient mass sampler (RAMS) and more recently the Rupprecht & Patashnick Filter Dynamic Measuring System (FDMS), have been developed to measure total $PM_{2.5}$ mass, including SVM. Real-time instruments have several advantages including, reliability, cost effectiveness, ease of sampling and reduction in labor requirements. One of the main advantages of real-time instruments is the ability to temporally resolve short term episodes of $PM_{2.5}$ that occur in urban environments. One-h real-time data has also been shown to increase the performance (i.e., reduce uncertainty) of source apportionment techniques to determine sources, both primary and secondary, of urban PM (Grover *et al.*, in Press).

The application of these samplers to the study of atmospheric chemistry in urban environments has shown that a substantial fraction of the fine particulate matter (PM) in these environments is semi-volatile organic and nitrate material (SVM) (Eatough *et al.*, 2001; Long *et al.*, 2002; Long *et al.*, 2003). Furthermore, these studies have shown that the majority of the semi-volatile organic material (SVOM) is secondary (Eatough *et al.*, 2003). Because a significant portion of $PM_{2.5}$ has been shown to be semi-volatile and SVM may be important in cardiovascular human health effects (Pope *et al.*, 2000; Pope *et al.*, 2004), the development of instruments to accurately determine all components of urban $PM_{2.5}$ is important.

An intensive research campaign was conducted in Fresno, CA to determine most of the major components of ambient $PM_{2.5}$ including both the nonvolatile and semi-volatile organic and inorganic fractions of the urban aerosol. Inter-comparisons were made between several real-time measurement systems and one integrated method.

6.2. Fresno Sampling Site

The sampling site was located in the parking area of the Veterans Hall Federal Post 509 adjacent to the Fresno, CA EPA Supersite (Watson, *et al.*, 2000) operated by the California Air Resource Board (CARB). This site is centrally located in the major Fresno metropolitan area and approximately 0.8 km east of California highway 41. Fresno is located in the Central San Joaquin Valley which is home to an estimated 3.2 million residents. Fresno is an urban area consisting of approximately 850,000 residents according to U.S. Census Bureau estimates in 2003 (www.census.gov). It is located on the valley floor approximately 100 meters above sea level and is surrounded by the Sierra Nevada mountain range on the east and coastal mountains to the west. These geographical conditions abet the development of high urban pollution aerosol concentrations which often occur in the Fresno area.

During the winter months, Fresno is often impacted by strong inversion layers, resulting in time periods of high $PM_{2.5}$ concentrations as well as other pollutants (Watson and Chow, 2002). Mobile emission sources of particulate pollution, as well as wood combustion from wood burning stoves, contribute to $PM_{2.5}$ concentrations during the winter months. High humidity often results in persistent low altitude fog during inversion episodes, resulting in a highly water saturated aerosol.

6.3. Sampling Methods

The various samplers used to monitor $PM_{2.5}$ included samplers to determine mass and chemical components. Each of the samplers used in this study is given in the following sections and details of the samplers have been outlined in Chapter 2.

R&P TEOM Monitor. Hourly data from two TEOMs were obtained during the study, including a BYU TEOM operating at 30 °C and the CARB TEOM operating at 50 °C (Patashnick and Rupprecht, 1991). Semi-volatile PM is not retained on a conventional TX40 filter at these elevated temperatures, which is required to remove particle-bound water (Mignacca and Stubbs, 1999). With the elevated TEOM filter temperature, this technique measures only non-volatile PM.

R&P FDMS 8500 Unit. This system is designed to measure total PM_{2.5} mass including both the non-volatile and semi-volatile fractions using TEOM technology. Two FDMS TEOMs were used in this study. In each unit the TEOM TX40 filter was maintained at the standard operating temperature of 30 °C. Hourly averaged concentrations of total PM_{2.5} concentrations were obtained with the two FDMS monitors. Hourly averaged SVM concentrations were also obtained from purge cycle data.

R&P Differential TEOM. Hourly averaged concentrations of total PM_{2.5} were obtained with two differential TEOMs in this study for comparison with other semi-continuous mass measurement techniques.

GRIMM Model 1100 Monitor. A conventional GRIMM monitor was used to measure hourly averaged PM_{2.5} at ambient temperature. A collocated GRIMM monitor was also applied in this study, which used an inlet equipped with a heater operated at 80 °C, resulting in a temperature of 50 °C in the laser measured aerosol, for comparison with heated TEOM mass data.

Met One Instruments Beta Attenuation Mass (BAM) Monitor. Hourly averaged PM_{2.5} mass data were obtained during the study with the BAM monitor. This instrument was operated by the CARB at the EPA Fresno Supersite.

Dionex GP-IC: Fine Particulate Ammonium, Sulfate, and Nitrate.

Instrumentation for the measurement of atmospheric inorganic species was outlined in detail in Chapter 2. The instrument used in this study was similar to the TTU prototype instrument. Fine particulate nitrate, sulfate and ammonium ion concentrations were averaged over 1-h periods for comparison with other semi-continuous data. The recently commercialized version of this instrument, the Dionex GP-IC, was field tested for the first time during this study.

R&P Series 8400N Nitrate Monitor. Hourly averaged concentrations of atmospheric nitrate were obtained during the study with a R&P 8400N monitor for comparison with the Dionex GP-IC nitrate data. This instrument was operated by the CARB at the Fresno EPA Supersite.

R&P Series 8400S Sulfate Monitor. Semi-continuous sulfate data was also obtained with an R&P 8400S monitor. One-h averaged concentrations were obtained for comparison with the Dionex GP-IC system. Due to problems associated with this instrument, data were only obtained during the initial 10 days of the sampling period. This instrument was operated by the CARB at the Fresno EPA Supersite.

R&P Series 5400 Ambient Carbon Particulate Monitor. The Series 5400 ambient carbon particulate monitor from Rupprecht & Patashnick was used to characterize the carbon content of fine particles on a continuous basis. Organic carbon was assumed to be organic material. It was assumed that fine particulate organic material was 62% carbon, typical of an aged urban aerosol (Turpin and Lim, 2001). Carbon concentrations using the R&P 5400 were obtained by both an instrument operated by Brigham Young University and one operated by the EPA Fresno Supersite.

Sunset Laboratory Carbon Monitor. One-h average OC and EC concentrations were obtained with a Sunset Laboratory carbon monitor. The configuration and operation of the conventional Sunset monitor were detailed in Chapter 2. The CARB at the EPA Fresno Supersite maintained and operated this instrument during the study.

Integrated PC-BOSS Determination of PM_{2.5} Composition and Mass. The configuration and operation of the PC-BOSS is detailed in Chapter 2. In this study, the PC-BOSS was used to determine fine particulate mass, sulfate, carbonaceous material (elemental and organic), nitrate, semi-volatile organic material, and semi-volatile nitrate.

6.4. Sample Collection

Sampling was conducted in Fresno, CA from December 1-23, 2003. One-h averaged data were obtained from all instruments listed above excluding the PC-BOSS and the Dionex GP-IC system. High PM pollution concentration days were forecasted during the study for the collection of PC-BOSS data. Subsequently, 3-h PC-BOSS data were obtained on 4 days during the sampling campaign (15th, 17th, 18th and 22nd). The Dionex GP-IC provided 15-min data resolution which was then averaged to provide 1-h averaged data for comparison with the other instruments used in the study. Several of the instruments including the R&P 8400N nitrate and 8400S sulfate monitors, the Met One BAMs, the Sunset carbon monitor and an R&P 5400 C monitor were operated by the EPA Fresno Supersite.

6.5. Results

6.5.1. PC-BOSS Integrated Constructed Mass vs. Real-Time Total Mass

Measurements

Total PM_{2.5} mass concentrations from the PC-BOSS can be obtained as the sum of sulfate and nitrate (assumed to be present as the ammonium salts), NVOM and SVOM (assumed to be 62% carbon) (Turpin and Lim, 2001), and EC. Comparisons between constructed mass obtained by the PC-BOSS and R&P FDMS and R&P differential TEOM monitors were made. Three PC-BOSS 3-h samples were not included in the comparisons due to incomplete analysis of the organic material, resulting in 29 comparisons between constructed integrated mass and real-time mass measurements. Real-time concentration data were averaged over the PC-BOSS sampling time periods for comparison.

Excellent agreement was observed between the PC-BOSS and the R&P FDMS monitor, as illustrated in Figure 6.1 and Table 6.1. Linear regression analysis of the R&P FDMS (x) and the PC-BOSS (y) data resulted in a zero-intercept regression slope = 1.00 ± 0.02 with an $R^2 = 0.93$ and an intercept calculated slope of 0.88 ± 0.04 with an $R^2 = 0.95$ and an intercept of $6.7 \pm 4.3 \text{ g/m}^3$. The calculated uncertainty in the comparison resulted in $\pm 3.6 \text{ g/m}^3$ or $\pm 7.3\%$ which is consistent with the expected uncertainty in the PC-BOSS measurement.

Linear regression analysis was also performed on a comparison between the average PM_{2.5} mass concentrations obtained with the collocated R&P differential TEOMs (x) and the PC-BOSS constructed mass data (y). A zero-intercept regression

Figure 6.1. Comparison of FDMS measured mass with 3-h PC-BOSS integrated mass.

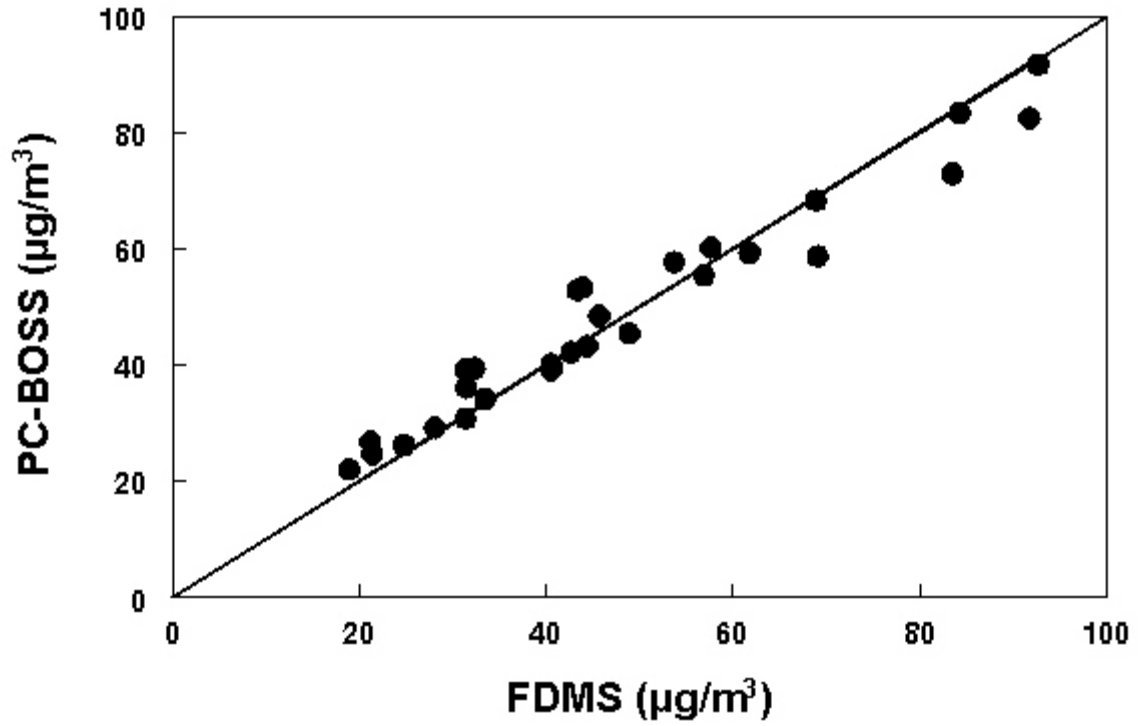

Table 6.1. Linear Regression Analysis Results of the R&P FDMS (X) Compared to Other Real-Time Mass Measurement Instruments.

X vs Y	n	R ²	Slope ^a	Intercept g/m ³	X Average g/m ³	X-Y Bias g/m ³	g/m ³	%
R&P FDMS vs PC-BOSS	29	0.93 0.95	1.00±0.02 0.88±0.04	0 6.7±4.3	48.5	-0.5	3.6	7.3
R&P FDMS vs FRM	5	1.00 1.00	0.97±0.01 1.00±0.03	0 -1.1±1.1	31.3	1.1	1.0	3.1
R&P Differential TEOM vs PC- BOSS	29	0.88 0.90	1.28±0.03 1.11±0.07	0 7.5±6.1	37.2	-11.7	9.2	21.4
R&P FDMS (1) vs R&P FDMS (2)	290	0.98 0.98	1.03±0.00 1.00±0.01	0 1.2±2.5	28.8	-1.2	2.0	6.6
R&P Diff. TEOM (1) vs R&P Diff. TEOM (2)	232	0.99 0.99	1.08±0.00 1.05±0.01	0 0.8±2.2	27.7	2.2	2.3	8.5
TEOM (30 ^o C) vs TEOM (50 ^o C)	507	0.90 0.91	0.85±0.01 0.80±0.01	0 1.1±3.1	13.9	1.6	3.3	25.0
R&P FDMS vs R&P TEOM (30 ^o C)	516	0.68 0.68	0.46±0.01 0.50±0.01	0 -1.7±6.9	13.6	17.4	15.1	67.2
R&P FDMS vs R&P Differential TEOM (Entire Study)	465	0.89 0.90	0.81±0.01 0.78±0.01	0 1.5±5.4	32.7	5.7	6.4	21.5
R&P FDMS vs R&P Differential TEOM (Dec. 1-7, 10-13)	219	0.97 0.97	0.90±0.01 0.90±0.01	0 -0.1±2.9	31.3	3.3	3.4	11.4
R&P FDMS vs Met One BAMs	528	0.84 0.85	0.94±0.01 0.85±0.02	0 3.9±7.9	29.6	-0.7	0.6	2.0
R&P FDMS vs GRIMM 1100	496	0.79 0.85	0.97±0.01 0.80±0.02	0 7.4±6.9	31.5	-1.2	5.7	17.7

^aSlopes are given for (1) zero intercept and (2) calculated intercept

slope of 1.28 ± 0.03 with an $R^2 = 0.88$ was observed. An intercept calculated slope of 1.11 ± 0.07 resulted in an $R^2 = 0.90$ and a intercept of $7.5 \pm 6.1 \text{ g/m}^3$. The uncertainty in the comparison was $\pm 9.2 \text{ g/m}^3$ ($\pm 21.4\%$).

A comparison between the R&P FDMS and the R&P differential TEOM monitor, Figure 6.2, reveals good agreement at lower concentrations, and deviation at higher concentrations was obtained. These high concentration values were consistently observed at peak episodes throughout the study and a plausible explanation for the difference between the PC-BOSS and R&P FDMS compared to the R&P differential TEOM monitor is explained in a subsequent section of this chapter.

6.5.2. R&P FDMS vs FRM

Every sixth day, 24-h FRM samples were collected at the Fresno Supersite. R&P FDMS concentrations were averaged over each 24-h period and compared to concentrations obtained by the FRM. Generally, the FRM underestimates $PM_{2.5}$ concentrations due to the loss of SVM not retained by the single filter sampler (Grover *et al.*, 2005). However during this sampling campaign, good agreement was observed between the R&P FDMS and the FRM. Linear regression statistics are given in Table 6.1.

The agreement between the R&P FDMS and the FRM can be explained. Lower $PM_{2.5}$ concentrations were observed during December 11th, 23rd and 29th with little or no SVM present in the aerosol. These three sampling days were also impacted by intermittent rain resulting in the observed low concentrations of $PM_{2.5}$. The FRM sample obtained on December 5th occurred during the strong persistent inversion, accompanied

Figure 6.2. Comparison of R&P FDMS and R&P differential TEOM monitors.

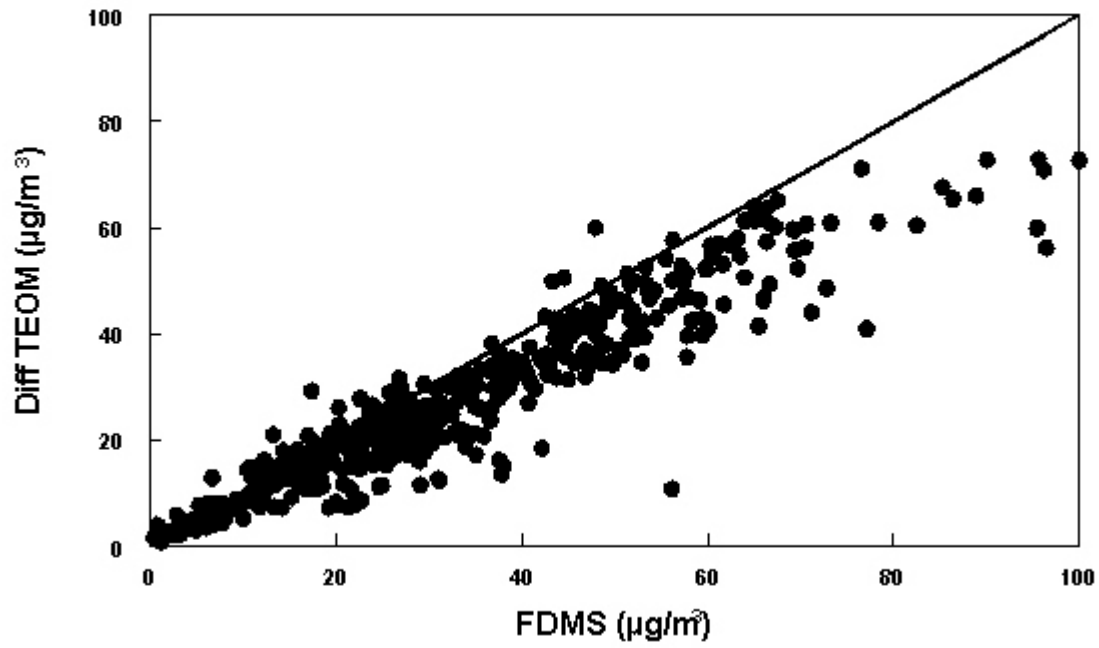

by high humidity and high $PM_{2.5}$ concentrations, that was observed at the beginning of the sampling period. During this time period, the SVM was dominated by ammonium nitrate. Previous studies have indicated semi-volatile ammonium nitrate is often not lost from the FRM Teflon filter under winter temperature conditions and high humidity (Long *et al.*, 2003). SVM on December 17th was not, however, dominated by ammonium nitrate and approximately 88% of the SVM was SVOM. However during the evening period, when the aerosol had high concentrations of SVM, high humidity (~90% RH) and cold temperatures (~7 °C) were also observed. Reasonably, SVM could be stabilized by cold and humid conditions as were observed on December 17.

6.5.3. Real-Time Mass Comparisons

Hourly averaged mass measurements from the monitoring instruments were compared: two R&P FDMS monitors, two R&P differential TEOM monitors, an R&P TEOM monitor, a Met One BAMS, a conventional GRIMM monitor and a GRIMM monitor equipped with a heated inlet. Data recovery for each of the instruments was greater than 99% for the R&P FDMS, 86 % for the differential TEOMs, 99% for the conventional 50 °C and 30 °C TEOM, 98% for the BAMS, 98% for the GRIMM, and 95% for the GRIMM with a heated inlet. Incomplete data recovery was mostly the result of two major power outages that occurred at the sampling site during the study. Comparisons between instruments were only made when both instruments were operating, and the number of data points are indicated in Table 6.1. The R&P 8500 FDMS monitor was used as a benchmark for comparison because this monitor has been shown to measure total $PM_{2.5}$ concentrations including both the nonvolatile and semi-volatile fractions (Grover *et al.*, 2005) and was in agreement with the PC-BOSS data. As

Figure 6.3. Real-time mass monitor data for R&P FDMS vs R&P differential TEOM (A), MetOne BAM (B) and conventional GRIMM monitor and heated GRIMM monitor (C).

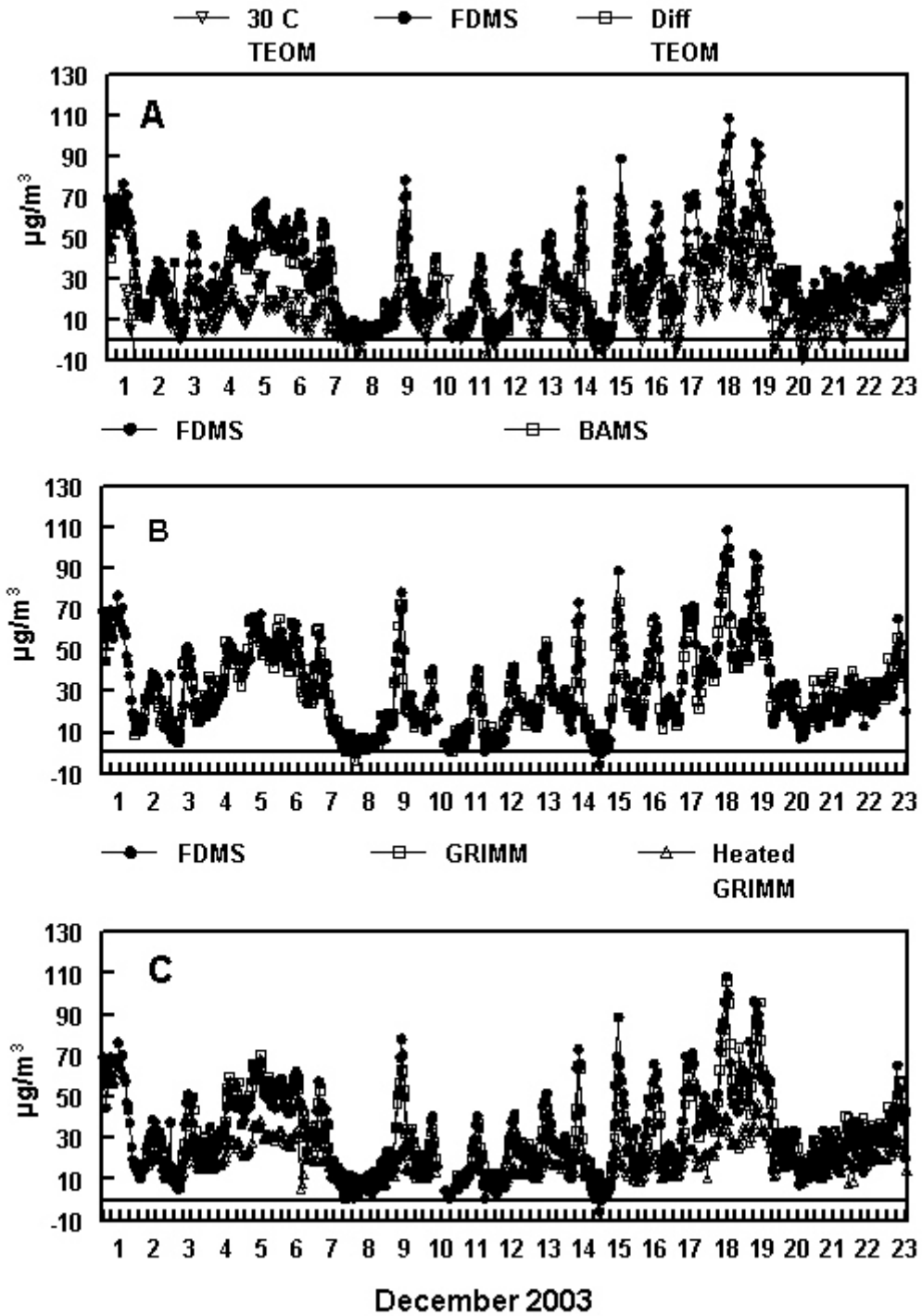

shown in Figure 6.3, a diurnal pattern was observed with concentrations increasing during the evening rush hour period and reaching maxima during the nighttime hours. This increase in $PM_{2.5}$ mass concentration is believed to be associated with a decrease in meteorological boundary layer as the temperature decreased during the winter nights throughout the study period. Furthermore, evening rush hour and wood smoke emissions also contribute to increased nighttime concentrations (Watson and Chow, 2002). Generally low daytime concentrations were observed throughout the study. An exception to this pattern was seen December 4-6 when a persistent inversion with fog was present.

6.5.4. Precision of Collocated R&P FDMS and R&P Differential TEOM

Monitors

Precision measurements were only made for the R&P FDMS monitors during the December 1-13 period. After this time period, one of the FDMS monitors was not operating properly for the remainder of the study period due to the malfunction of a computer board. As shown in Table 6.1 good agreement was observed between the two FDMS monitors with a bias of only -1.2 g/m^3 and $\pm 2.0 \text{ g/m}^3$ or $\pm 6.6\%$.

Precision measurements for the R&P differential TEOM monitors were also only made during the December 1- 13 time period. Starting on December 14, operating conditions on one of the R&P differential TEOM monitors was changed for the rest of the study period. Good agreement was also observed between the collocated R&P differential TEOMs as shown in Table 6.1. A bias of 2.2 g/m^3 between the two instruments was observed with $\pm 2.3 \text{ g/m}^3$ or $\pm 8.5\%$.

6.5.5. R&P FDMS vs R&P TEOM

Due to the loss of SVM from the heated inlet of the TEOM monitor (Grover *et al.*, 2005; Long *et al.*, 2002; Long *et al.*, 2003), TEOM measured mass concentrations were normally below or equal to FDMS measured mass concentrations as shown in Figure 6.3A. Linear regression analysis, shown in Table 6.1, indicates the magnitude of SVM loss during the study period. A zero-intercept slope of 0.46 ± 0.01 was obtained with $R^2 = 0.67$. The intercept calculated slope was 0.50 ± 0.01 with $R^2 = 0.68$ and an intercept of $-1.7 \pm 6.9 \text{ g/m}^3$. A sigma value of $\pm 15.0 \text{ g/m}^3$ or $\pm 67\%$ was obtained for the comparison.

6.5.6. R&P FDMS vs. R&P Differential TEOM

During the majority of the sampling period, good agreement was observed between the FDMS and the differential TEOM measurements. Some exceptions were observed at peak concentration time periods on December 8, 13, 14, 15, 17, and 18 as shown in Figure 6.3A. Linear regression analysis, for the entire sampling period, resulted in a zero-intercept slope of 0.81 ± 0.01 with an $R^2 = 0.89$ and $n = 465$. An intercept calculated slope linear regression gave a slope = 0.78 ± 0.01 with $R^2 = 0.90$ and an intercept of $1.5 \pm 5.4 \text{ g/m}^3$. The bias between the two measurement systems was 5.7 g/m^3 with $\pm 6.4 \text{ g/m}^3$ or $\pm 21.5\%$.

Focusing on time periods in which the observed peak exceptions did not occur (December 1-7 and December 10 - 13), a linear regression analysis resulted in a zero-intercept linear slope of 0.90 ± 0.01 and $R^2 = 0.97$ and the intercept calculated slope was

0.90 ± 0.01 with an $R^2 = 0.97$ and an intercept of $-0.1 \pm 2.9 \text{ g/m}^3$. The observed bias excluding peak exceptions was 3.3 g/m^3 with $\text{bias} = \pm 3.4 \text{ g/m}^3$ or $\pm 11.4\%$.

6.5.7. R&P FDMS vs. Met One BAM

Good agreement was observed during the sampling period with some scatter occurring at higher mass concentrations as shown in Figure 6.3B. A linear regression analysis zero-intercept slope of 0.94 ± 0.01 with an $R^2 = 0.84$ was obtained. A slope of 0.85 ± 0.02 with an $R^2 = 0.85$ and an intercept of $3.9 \pm 7.9 \text{ g/m}^3$ was observed for an intercept calculated regression. Although the comparison between the two instruments was somewhat noisy as indicated by the lower R^2 value, little bias was observed (bias = 0.7 g/m^3) with $\text{bias} = \pm 0.6 \text{ g/m}^3$ or $\pm 2.0\%$.

6.5.8. R&P FDMS vs. Non-Heated and Heated GRIMM 1100 Monitor

As shown in Figure 6.3C, good agreement was observed between the conventional GRIMM monitor and the R&P FDMS monitor with few exceptions. During peak concentration periods from December 8-17 the GRIMM mass concentrations were substantially lower than the R&P FDMS mass, and were also lower than the concurrent BAMs measurement. However, at other peak concentration time periods the GRIMM monitor measurement was equal to that obtained by the R&P FDMS monitor. The GRIMM monitor measurement was also noticeably higher during an initial inversion period on December 3-6 and some rainy periods throughout the study as seen on December 8-9 and again on December 21-22. The inversion period was accompanied by high humidity and low level fog as well as high nitrate concentrations. Therefore, the overestimated mass measurement by the GRIMM monitor at these time periods may be

the result of water uptake due to the hygroscopic nature of urban $PM_{2.5}$, especially with high nitrate concentrations (Grover *et al.*, 2004). Linear regression analysis of the R&P FDMS (x) and the conventional GRIMM monitor (y) resulted in a zero-intercept calculated slope of 0.97 ± 0.01 , $R^2 = 0.80$ with $n = 496$. The intercept calculated slope was 0.80 ± 0.02 with an $R^2 = 0.85$ and an intercept of $\pm 7.4 \text{ g/m}^3$. The uncertainty in the comparison was $\pm 5.7 \text{ g/m}^3$ or $\pm 17.7\%$.

The $PM_{2.5}$ concentration measurement by the heated GRIMM monitor was substantially lower than the R&P FDMS measurement and the conventional GRIMM measurement throughout the study. This is mainly due to the loss of SVM by the heated inlet of the modified GRIMM monitor. $PM_{2.5}$ mass from the heated-inlet GRIMM monitor more closely resembled those obtained by the conventional TEOM monitor.

6.5.9. Particulate Carbon Measurements

Diurnal patterns in carbon concentrations tended to track $PM_{2.5}$ mass concentrations as measured by the R&P FDMS. Generally good agreement between the two semi-continuous carbon monitors was observed for TC at low concentrations, and significant deviations were observed at higher concentrations with linear regression statistics given in Table 6.2. During the inversion period observed at the beginning of the study (December 1-7), good agreement was observed between the two carbon monitors. During the later part of the study, when a diurnal pattern with high nighttime concentrations was observed, the Sunset monitor concentration was often greater than the R&P 5400 with very low correlations ($R^2 = 0.22$). Previously, the R&P 5400 carbon monitor was shown to underestimate SVOM (Anderson *et al.*, 2002) especially at higher

concentrations as were observed in this period of the study. Furthermore, the aerosol during the initial inversion period was dominated by ammonium nitrate with low particulate carbon concentrations. During the later part of the study, when deviations were observed, the aerosol had much higher carbon concentrations as well as significant concentrations of semi-volatile carbon.

Where PC-BOSS data were available, comparisons were made between PC-BOSS 3-h integrated total carbon concentrations with averaged carbon concentrations determined by the respective semi-continuous monitors and are given in Table 6.2. Zero-intercept slopes of 0.67 ± 0.04 and 0.80 ± 0.03 were determined for the R&P 5400 and the Sunset, respectively.

6.5.10. Inorganic Constituent Measurements

Hourly averaged concentrations of particulate sulfate, nitrate and ammonium ion determined by the Dionex GP-IC and the R&P systems during the study period are shown in Figure 6.4. Throughout the study, concentrations of nitrate were higher than sulfate concentrations with the averaged concentrations, for the more complete GP-IC data set, of 8.09 g/m^3 and 1.51 g/m^3 , respectively. Fine particulate ammonium ion concentrations tended to track fine particulate nitrate concentrations through the study.

The sum of the concentrations of 3-h averaged nitrate collected on the PC-BOSS Teflon filter and the lost semi-volatile nitrate collected on the PC-BOSS backup nylon filter were compared to nitrate concentrations (averaged from 12-15 nitrate samples) determined by the GP-IC system. As shown in Table 6.2, good agreement was observed between the 29 paired nitrate measurements on the two systems with a zero-intercept

Table 6.2. Results of Linear Regression Analysis for Fine Particulate Chemical Species.

X vs Y	n	R ²	Slope ^a	Intercept g/m ³	X Average g/m ³	X-Y Bias g/m ³	g/m ³	%
PC-BOSS vs GP- IC Nitrate	29	0.74 0.91	0.98±0.03 0.71±0.04	0 3.2±1.1	9.4	-0.5	1.3	13.7
PC-BOSS vs GP- IC Sulfate ^b	27	0.98 0.98	1.06±0.02 1.03±0.03	0 0.2±0.3	2.4	-0.2	0.3	11.0
PC-BOSS vs R&P Nitrate	29	0.93 0.93	1.04±0.03 1.10±0.06	0 -0.8±1.8	9.0	-0.1	1.3	14.2
GP-IC vs R&P Nitrate	493	0.69 0.75	0.67±0.01 0.55±0.01	0 1.4±1.8	8.0	2.2	2.6	18.9
GP-IC vs R&P Sulfate	195	0.66 0.68	1.07±0.03 0.95±0.05	0 0.3±0.6	1.5	-0.2	0.4	14.1
Sunset C vs R&P 5400 C	480	0.22 0.73	0.83±0.01 0.50±0.01	0 3.6±1.5	6.9	-0.1	2.1	30.4
PC-BOSS TC vs Sunset TC	29	0.79 0.86	0.79±0.03 0.63±0.05	0 4.1±3.2	17.6	2.4	4.1	25.2
PC-BOSS TC vs R&P 5400 TC	29	0.38 0.91	0.67±0.04 0.41±0.02	0 6.7±1.6	17.6	3.7	5.7	36.1

^aSlopes are given for (1) zero intercept and (2) calculated intercept

^bTwo Statistical Outliers were not included in the analysis

Figure 6.4. Real-time concentrations of nitrate, sulfate and ammonium ions determined by the Dionex GP-IC system. R&P nitrate concentrations and R&P sulfate concentrations are included. Also shown are data from the Sunset carbon monitor and the R&P 5400 carbon monitor. Note that X-axis concentrations are different for each graph.

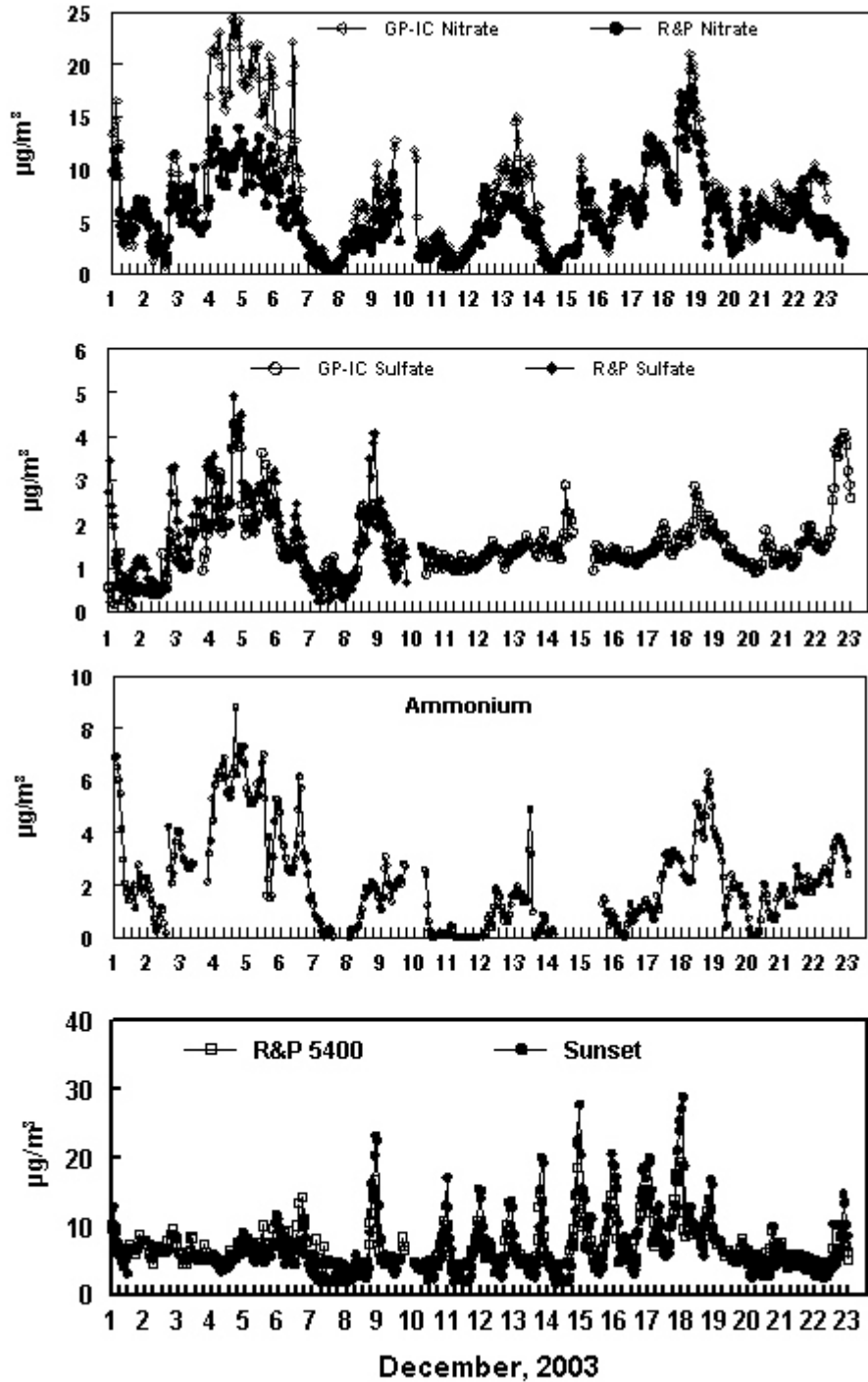

calculated slope close to unity and a bias of only -0.5 g/m^3 . The uncertainty in the comparison was $\pm 1.3 \text{ g/m}^3$ or $\pm 13.7\%$. We conclude that total nitrate concentrations, including semi-volatile nitrate, were measured by the GP-IC system under the range of conditions observed in this study with acceptable precision.

Major differences were observed between the R&P 8400N and the GP-IC nitrate data as shown in Figure 6.4. The most significant differences were observed during a persistent inversion at the beginning of the sampling period, which was associated with ground level fog and high humidity. Incomplete flash volatilization by the R&P Nitrate monitor under conditions of high humidity (Long and McClenny, Submitted) may explain the differences observed between the two monitoring techniques. Unfortunately, PC-BOSS data were not obtained during this time period of the sampling campaign.

A comparison was made between sulfate collected on the Teflon filter of the PC-BOSS and sulfate concentrations obtained by the GP-IC system. A resulting bias of 0.3 g/m^3 was observed. Two statistical outliers were removed for regression analysis resulting in 27 data pairs. Although generally low concentrations of sulfate were observed throughout the sampling period, Table 6.2 shows good agreement was observed between the two measurement systems, with a precision of $\pm 0.3 \text{ g/m}^3$ or $\pm 11.0\%$.

Sulfate data from the R&P 8400S were only available for the initial 10 days of the sampling period as shown in Figure 6.4. The R&P sulfate monitor and the GP-IC system were in good agreement with an uncertainty of $\pm 0.4 \text{ g/m}^3$, which is comparable to the estimated uncertainty of semi-continuous monitoring data of $\pm 0.3 \text{ g/m}^3$. Linear

regression statistics show low correlations but give an intercept near zero and a slope close to unity.

An increased understanding of atmospheric chemical processes can be obtained by the simultaneous determination of atmospheric cations and anions. An acid neutral aerosol would be expected to exhibit equal equivalents of the major anions (sulfate + nitrate) and the ammonium ion. During the initial portion of the sampling period (December 1-7), an acid neutral aerosol was observed when a persistent inversion occurred. The equivalents of anions were sometimes greater than that of the ammonium ion during the later portion of the study. Either the aerosol was acidic or other cations besides the ammonium ion were present in the aerosol that were not measured during these time periods. This is illustrated in Figure 6.5. During the later portion of the study, concentrations of fine particulate mass measured by the R&P FDMS monitor exhibited increased concentrations during the late evening and nighttime hours associated with the formation of nocturnal inversion layers. A corresponding pattern was also observed for carbon measured by the R&P 5400 carbon monitor. The same pattern however is not observed with nitrate concentrations, which typically exhibited a diurnal pattern with increased concentrations during the daytime hours, shown in Figure 6.4. This diurnal trend is in accordance with daytime photochemistry that occurs, resulting in the formation of nitrate during time periods of high photochemical activity. Concentration data for nitrite and chloride ions were also routinely determined during the study using the Dionex GP-IC. Nitrite and chloride ion concentrations were typically low and approximately 2-5 % of the nitrate ion concentrations observed during the study.

Figure 6.5. Comparisons of 1-h average measurements of the anions (nitrate + sulfate) and the ammonium cation with the Dionex GP-IC system.

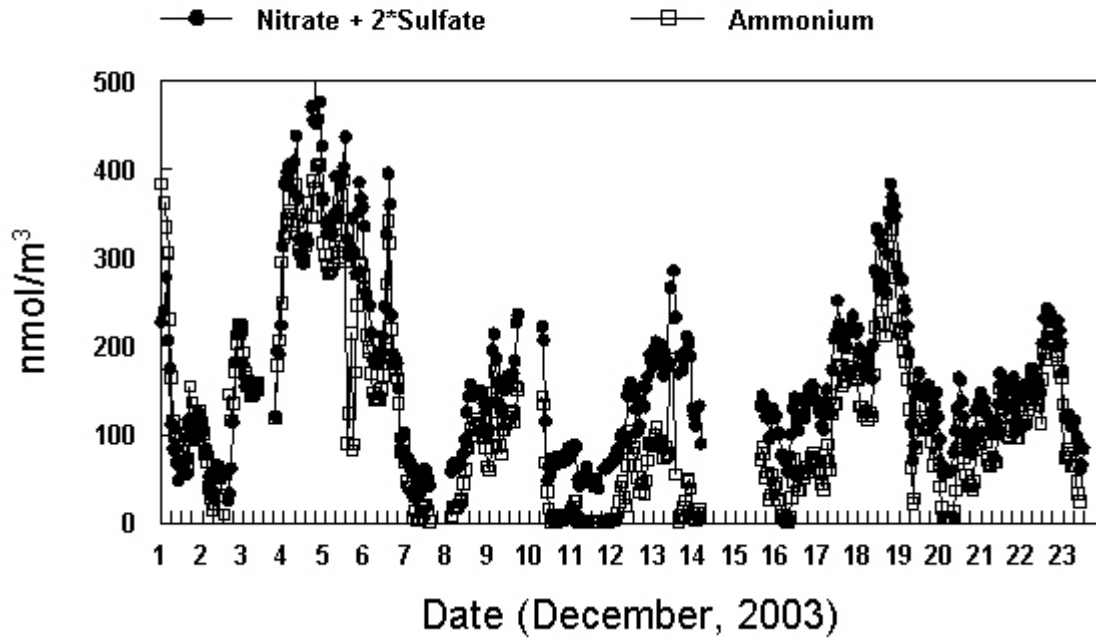

6.5.11. R&P FDMS and Constructed Real-Time Mass

A time-resolved sum of the major species of $PM_{2.5}$ determined by various instruments resulted in a semi-continuous constructed mass shown in Figure 6.6. Nitrate and sulfate concentrations were determined by the Dionex GP-IC and represented as ammonium nitrate and ammonium sulfate, respectively. Particulate carbon concentrations, including OC and EC, were measured using the Sunset carbon monitor. GP-IC inorganic and Sunset carbon data were used instead of the respective R&P nitrate and carbon monitors, because these instruments had better correlation with PC-BOSS data obtained during the study. OC concentrations were converted to organic material concentrations using a factor of 1.6 (Turpin *et al.*, 2001). Constructed mass data were compared to total $PM_{2.5}$ concentration data obtained by the R&P FDMS and nonvolatile $PM_{2.5}$ data obtained by the 30 °C and 50 °C TEOM monitors as shown in Figure 6.6. The difference between constructed mass and FDMS measured mass concentrations can be explained by the amount of SVOM which is measured by the FDMS but not by the Sunset carbon monitor. During the initial inversion period of the study (December 1- 7), when SVM was dominated by ammonium nitrate, constructed mass approached those measured by the R&P FDMS monitor. During the later part of the study (December 9- 23), high concentrations of organic material were observed during nighttime inversion periods. SVM during these time periods was not dominated by ammonium nitrate and had significant amounts of SVOM. Constructed mass concentrations more closely resembled non-volatile mass concentrations measured by the TEOM monitor because the SVOM was not measured by the Sunset carbon monitor or the TEOM monitor.

Figure 6.6. R&P FDMS vs constructed mass. Constructed mass consists of Dionex GP-IC nitrate and sulfate data represented as the ammonium salts, and Sunset carbon data.

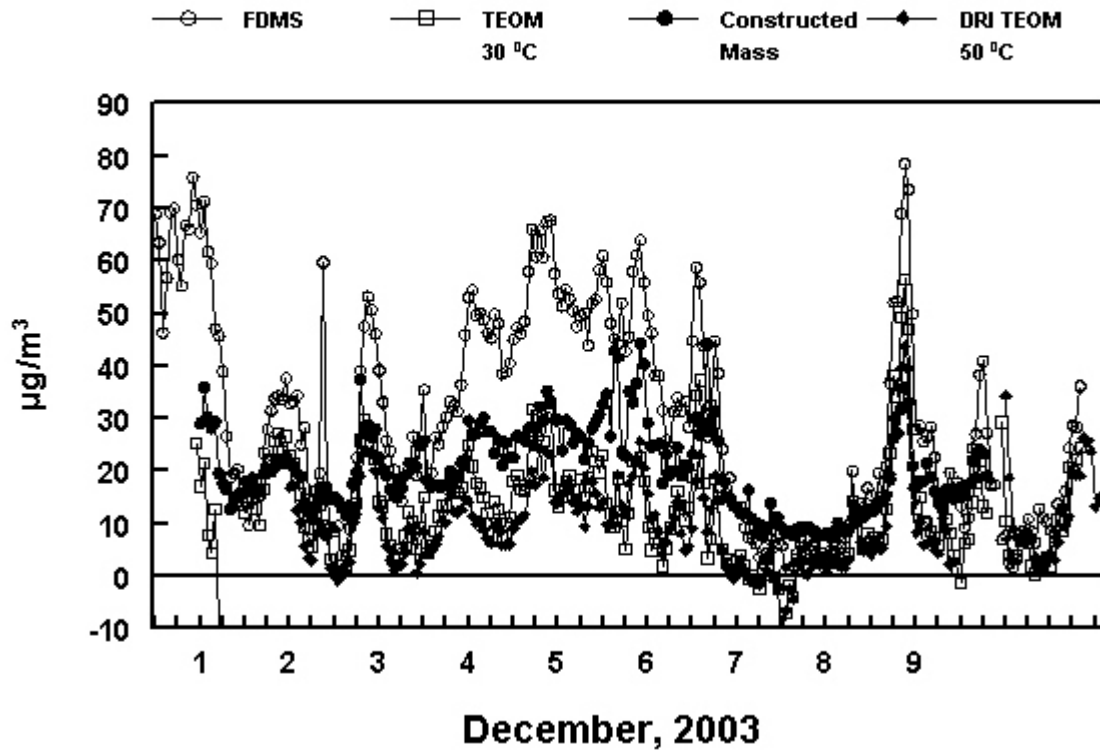

The TEOM operating at 50 °C often measured lower concentrations of PM_{2.5} throughout the study period as shown in Figure 6.6. This indicates that more of the SVM is lost from the collection filter at the higher operating temperature. Linear regression statistics for the TEOMs operating at different temperatures are given in Table 6.1.

6.5.12. SVM Comparison

Less of the SVM material was observed to be lost from the respective semi-continuous monitors than the TEOM monitor. A test of the difference between the amount of SVM lost was made by comparing the amount of SVM lost from the heated filter of the TEOM monitor and that collected by the PC-BOSS (including both SVOM and semi-volatile nitrate). Three-h averaged concentrations were determined for the FDMS and TEOM monitors for comparison with the PC-BOSS sampling periods. Three-h averaged SVM concentrations lost from the TEOM monitor were calculated as the FDMS concentration minus the TEOM concentration. During the majority of periods when PC-BOSS data were collected, the amount of SVM lost from the TEOM monitor was 15-18 g/m³ greater than the amount lost from the Teflon (nitrate) and quartz (organic material) filters of the PC-BOSS, as shown in Figure 6.7. Including the entire study period, an average of 6.0 g/m³ more SVM was lost from the TEOM monitor than the respective PC-BOSS filters for all time periods when PC-BOSS data were available.

6.6. Discussion

Meteorological conditions resulted in a persistent inversion that occurred during the initial week of the study period (December 1-7) causing high PM_{2.5} concentrations. This inversion was accompanied by high RH (%) and persistent ground level fog.

Figure 6.7. Comparison of the amount of SVM lost From the TEOM monitor (FDMS-TEOM) and that collected on the respective filters of the PC-BOSS (PC-BOSS SVM). Also shown are the 3-h averaged PM_{2.5} concentrations measured by the FDMS.

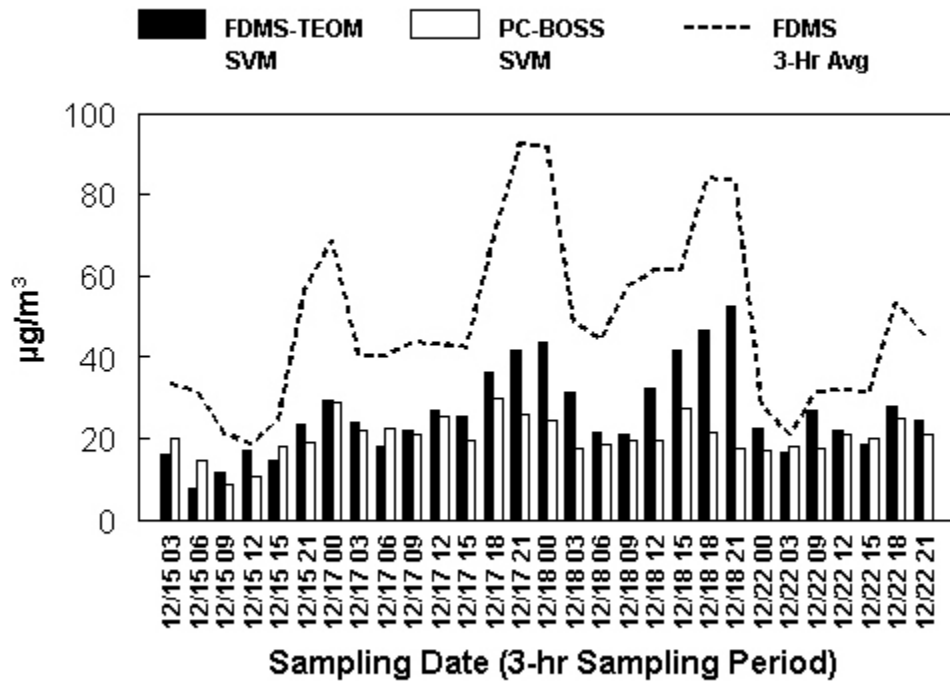

During this initial inversion period, relatively good agreement was observed for the R&P FDMS, the R&P differential TEOM, the GRIMM monitor, and the Met-One BAMs with the exceptions of the higher GRIMM measurement seen at some time periods during the inversion due to the presence of water in the aerosol as previously mentioned (Grover *et al.*, submitted). Following this initial persistent inversion, a typical diurnal pattern with high nighttime concentrations developed and good agreement was observed between the measurement systems during daytime non-peak concentration periods. However, significant differences were observed during nighttime peak concentrations during the later part of the study.

The differences observed at peak concentrations between the various measurement systems in the later part of the study (December 8 - 19) warrants some discussion. A comparison was made between each of the real-time mass measurement systems, excluding the conventional TEOM monitor and the heated GRIMM monitor. The R&P FDMS at the maximum 1-h peak concentration for each day during December 8-19 frequently gave higher concentrations than were observed between the other continuous measurement techniques. On December 8, 13, and 14 the R&P FDMS exhibited over 5 $\mu\text{g}/\text{m}^3$ higher concentrations than all the other measurement systems. On all other days during the later period of the study, one or more of the other measurement techniques was comparable to the R&P FDMS. The difference at peak concentrations between the R&P FDMS and the Met-One BAMs, the conventional GRIMM, and the R&P differential TEOM for all peak values between December 8-19 was 6.0 $\mu\text{g}/\text{m}^3$, 9.1 $\mu\text{g}/\text{m}^3$, and 16.1 $\mu\text{g}/\text{m}^3$, respectively.

The high degree of variability between the measurement systems at the peak concentrations is most likely associated with the complexity of the aerosol being measured. Meteorological conditions resulted in consistent nighttime inversion layers and high PM_{2.5} concentrations. These diurnal peak concentrations were normally associated with dense low altitude fog resulting in a high water content associated with the PM_{2.5}. This high water content in the aerosol may play a role in the variance seen between the different measurement techniques. The RH (%) and R&P FDMS concentrations are shown throughout the study in Figure 6.8. The differences seen between measurement systems at the initial inversion period and at peak concentrations during the later part of the study are associated with time periods of high RH (%). However, both the R&P FDMS monitor and the R&P differential TEOM monitor use Nafion dryers to remove particle bound water prior to measurement and, therefore, would not be expected to be affected by aerosol water content.

Another factor that may be associated with the differences between the measurement systems is the composition of the SVM in the aerosol. An estimation of the amount of 1-h averaged SVM concentrations in the aerosol can be made by subtracting the hourly TEOM from the hourly FDMS mass measurements as shown in Figure 6.9 as FDMS-TEOM. Previous studies have shown that the sum of ammonium nitrate concentrations and SVOM concentrations accounts for the difference seen between the FDMS and TEOM measurement (Grover *et al.*, 2005) or the amount of SVM present in the aerosol. Also displayed in Figure 6.9 are the 1-h averaged concentrations of nitrate measured by the Dionex GP-IC represented as ammonium nitrate. During the initial portion of the sampling period, when good agreement was observed between the FDMS

Figure 6.8. R&P FDMS concentrations and relative humidity (%).

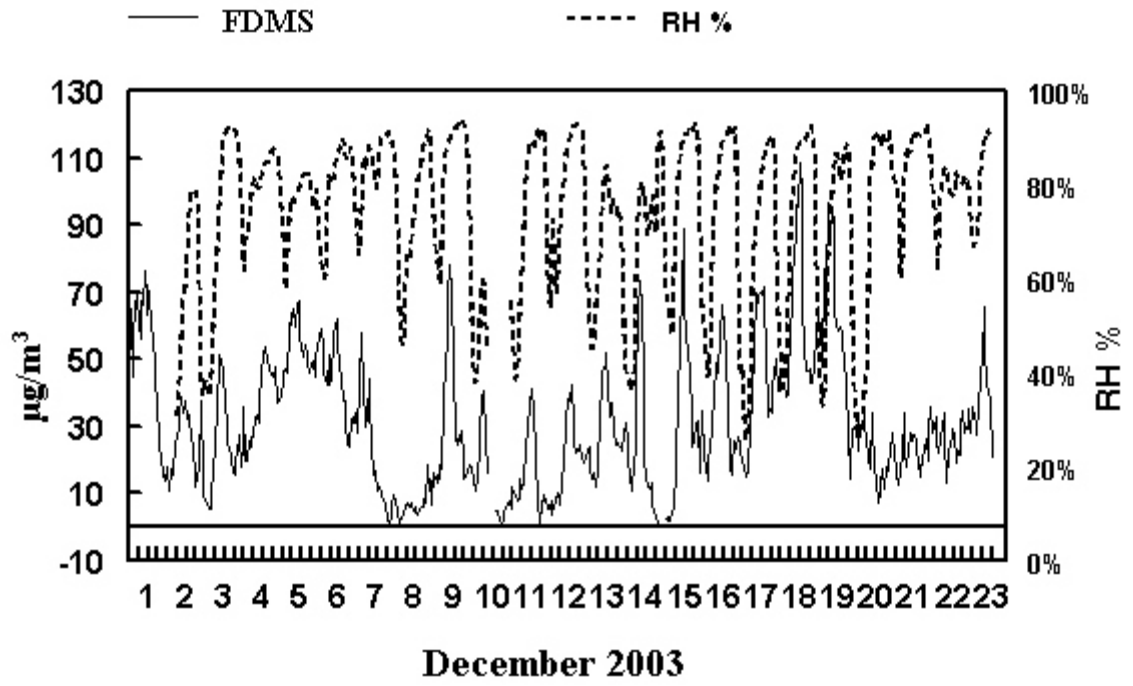
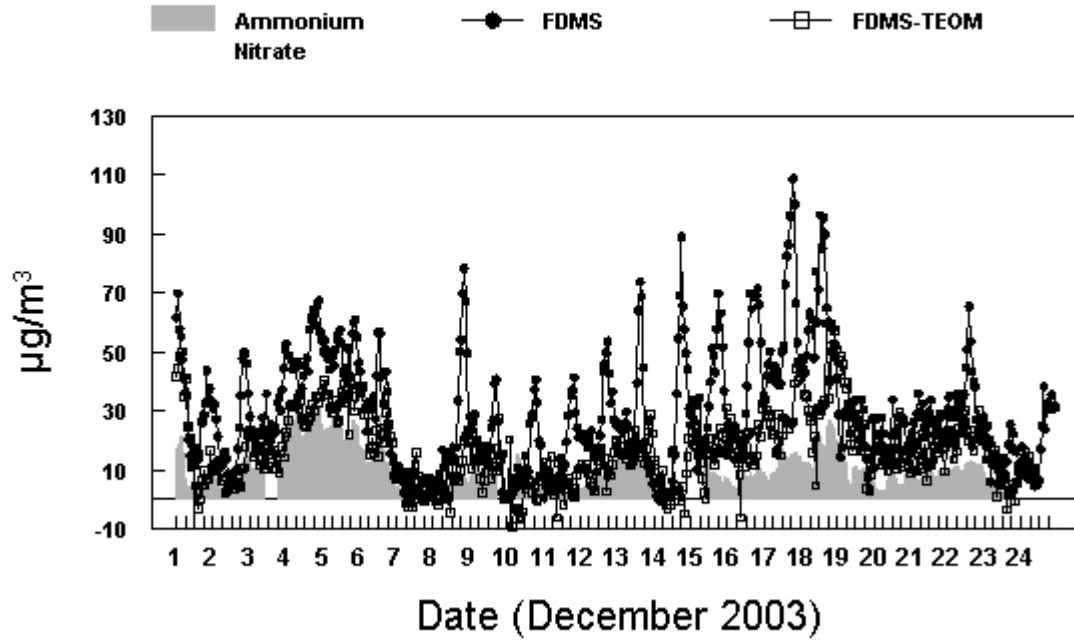

Figure 6.9. R&P FDMS measurement with real-time nitrate concentrations identifying varying composition in SVM at different time periods in the study.



and the other measurement systems, the SVM was dominated by ammonium nitrate. When peak exceptions were present, SVM is not dominated by ammonium nitrate but contains a large fraction of SVOM. A difference in composition of the SVM present in the aerosol may explain the differences in mass measurement seen between the FDMS and the other measurement systems at the peak concentration periods during the later period of the study. This explanation also accounts for the difference seen between PC-BOSS integrated constructed mass measurements and the differential TEOM mass measurements because PC-BOSS samples were only obtained on days in which SVOM was a large fraction of the total SVM.

6.7. Conclusions

During the time periods when collocated R&P FDMS or collocated differential TEOM monitors were operating properly, excellent agreement was observed. The resulting precision is well within the expected precision of the monitoring techniques.

Excluding peak concentration time periods during the later part of the study, relatively good agreement was observed between the R&P FDMS, the R&P differential TEOM, the Met One BAMs and the conventional GRIMM 1100. The conventional GRIMM monitor, at some high humidity time periods, may measure higher mass concentrations due to the inclusion of water in the measured mass. $PM_{2.5}$ mass acquired by the R&P TEOM and the GRIMM monitor with a heated inlet were substantially lower than the other measurement techniques throughout the majority of the study due to the loss of SVM.

Good agreement was observed between the PC-BOSS constructed mass measurement and the R&P FDMS averaged measurement for the four days of 3-h PC-

BOSS samples obtained. All four PC-BOSS sampling days occurred when significant differences were observed between the real-time measurement techniques. Also, good agreement was observed between the inorganic species concentrations obtained by the PC-BOSS and the Dionex GP-IC system. $PM_{2.5}$ nitrate, including the semi-volatile nitrate, was measured by the GP-IC system. The GP-IC proved to be a robust instrument with the advantage of the semi-continuous measurement of the major fine particulate ammonium ion and anion concentrations. Lower nitrate concentrations were measured with the R&P 8400N nitrate monitor under conditions of high humidity.

The observed peak concentration variance between the different real-time measurement techniques may be associated with the complexity of the aerosol being measured, including water content and SVM composition. However, a definitive explanation is not known at this time. Further investigation of the effect of SVM composition, especially SVOM, on real-time mass measurement is needed.

The real-time mass concentration instruments used during the study were all very robust, requiring little or no attention from the operator during the study period. The combination of real-time particulate mass with chemical species measurement is useful in gaining a better understanding of atmospheric aerosols.

6.8. References

Al-Horr, R., Samantha, G., and Dasgupta, P.K. (2003). A Continuous Analyzer for Soluble Anionic Constituents and Ammonium in Atmospheric Particulate Matter. *Aerosol. Sci. Technol.* 37: 5711-5720.

Al-Horr, R., Later, D. W., Grover, B. D., Eatough, N. L., Watson, J., Chow, J., and Eatough, D. J. (2004). A New Gas-Particle Ion Chromatographic System for the Continuous Monitoring of Soluble Gases and Ionic Constituents of Particulate Matter. *Proceedings of A&WMA 97th Annual Conference*, June 2004, Paper #763.

- Anderson, R. A., Martello, D. V., Rohar, P. C., Strazisar, B. R., Tmilia, J. P., Waldner, K., White, C. M., Modey, W. K., Mangelson, N. F., and Eatough, D. J. (2002). Sources and Composition of PM_{2.5} at the National Energy Technology Laboratory in Pittsburgh during July and August 2000. *Energy and Fuels*. 16: 261-269.
- Birch, M. E.; Cary, R. A. (1996). Elemental carbon-based method for occupational monitoring of particulate diesel exhaust: methodology and exposure issues. *Analyst* 121: 1183-1190.
- Boring, C.B., Al-Horr, R., Genfa, Z., Dasgupta, P.K., Martin M.W., and Smith, W.F. (2002). Field Measurements of Acid Gases and Soluble Anions in Atmospheric Particulate Matter using a Parallel Plate Wet Denuder and Alternating Filter-Based Automated Analysis System. *Anal. Chem.* 74: 1256-1268.
- Carter, C., Long, R. W., Eatough, N. L., and Eatough D. J., (2002). Comparison of Speciation Sampler and PC-BOSS PM_{2.5} Organic Material Results Obtained on the Wasatch Front During the Winter of 2001-2002. *Pro. AWMA 2002 Annual Conf.* 767.
- Chow, J. C. (1995). Measurement Methods to Determine Compliance with Ambient Air Quality Standards for Suspended Particles. *J. Air & Waste Manage. Assoc.* 45: 320-382.
- Chung, S. H., and Seinfeld, J. H., (2002). Global Distribution and Climate Forcing of Carbonaceous Aerosols. *J. Geophysical Research.* 107: 4407.
- Conant W. C., Seinfeld, J. H., Wang, J., Carmichael G. R., Tang, Y., Uno, I., Flatau, P. J., Markowicz, K. M., Quinn, P. K., (2003). A Model for the Radiative Forcing During ACE-Asia Derived from CIRPAS Twin Otter and R/V Ronald H. Brown Data and Comparison with Observation. *J. Geophysical Research.* 108: 8661.
- Dasgupta, P.K., Poruthoor, S.K. (2002). *Comprehensive Analytical Chemistry, 37th ed.*, J. Pawliszyn, ed., Elsevier Science B.V., Amsterdam, 2002; pp 161-276.
- Ding, Y., Pang, Y., Eatough, D.J., Eatough, N.L., and Tanner, R.L. (2002a). High-Volume Diffusion Denuder Samplers for the Routine Monitoring of Fine Particulate Matter: I. Design and Optimization of the PC-BOSS. *Aerosol Sci. Technol.* 36: 369-382.
- Ding, Y., Pang, Y., Eatough, D.J., Eatough, N.L., and Tanner, R.L. (2002b). High-Volume Diffusion Denuder Samplers for the Routine Monitoring of Fine Particulate Matter: II. Field Evaluation of the PC-BOSS. *Aerosol Sci. Technol.* 36: 383-396.
- Eatough, D. J., Eatough, D. A., Lewis, L., and Lewis, E. A., (1996) Fine Particulate Chemical Composition and Light Extinction at Canyonlands National Park using Organic Particulate Material Concentrations Obtained with a Multisystem, Multichannel Diffusion Denuder Sampler. *J. Geophysical Research.* 101: 19514-19531.

Eatough, D.J., Obeidi, F., Pang, Y., Ding, Y., Eatough, N.L., and Wilson, W.E. (1999). Integrated and real-time diffusion denuder samplers for PM_{2.5} based on BOSS, PC and TEOM technology. *Atmos. Environ.* 33: 2835-2844.

Eatough, D.J., Eatough, N.L., Obeidi, F., Pang, Y., Modey, W., and Long, R. (2001) Continuous determination of PM_{2.5} mass, Including Semi-Volatile Species. *Aerosol Sci. Technol.* 34: 1-8.

Eatough, D.J., Long, R.W., Modey, W.K., Eatough, N.L. (2003). Semi-Volatile Secondary Organic Aerosol in Urban Atmospheres: Meeting a Measurement Challenge. *Atmos. Environ.* 37: 1277-1292.

Grover, B. D, Carter, C. B. Kleinman, M. A., Richards, J. S., Eatough, N. L. and Eatough, D. J. Monitoring and Source Apportionment of Fine Particulate Matter at Lindon, Utah. Submitted to *Aerosol Sci. Technol.*

Grover, B .D., Kleinman, M. A., Eatough, N. L., Eatough, D. J., Hopke, P. K., Long, R. W., Wilson, W. E., Meyer, M. B., Ambs, J. L. (2005). Measurement of Total PM_{2.5} Mass (Nonvolatile plus Semi-Volatile) with the FDMS TEOM Monitor. *J. Geophysical Research.* In Press

Grover, B. D., Eatough, N. L., Hopke, P. K., and Eatough, D. J. Measurement of Fine Particulate Mass, Including the Semi-Volatile Constituents, with a GRIMM Monitor. *Proceedings of A&WMA 97th Annual Conference*, June 2004, Paper #51.

Godleski, J.J., Verrier, R.L., Koutrakis, P., and Catalano, P., (2000). Mechanisms of morbidity and mortality from exposure to ambient air particles. Health Effects Institute, research report no. 91.

Hering, S.; Cass, G. (1995). The Magnitude of Bias in the Measurement of PM_{2.5} Arising from Volatilization of Particulate Nitrate from Teflon Filters. *J. Air & Waste Manage. Assoc.* 49: 725-733.

Lewis, C. W., Norris, G. A., Conner, T. L., and Henry, R. C. (2003). Source Apportionment of Phoenix PM_{2.5} Aerosol with the Unmix Receptor Model. *J. Air & Waste Manage. Assoc.* 53: 325-338.

Lewtas, J., Booth, D., Pang, Y., Reimer, S, Eatough, D.J., and Gundel, L. (2001). Comparison of sampling methods for semi-volatile organic carbon (SVOC) associated with PM_{2.5}. *Aerosol Sci. Technol.* 34: 9-22.

Long, R.W., Smith, R., Smith, S., Eatough, N.L., Mangelson and Eatough, D.J. (2002a) Sources of Fine Particulate Material along the Wasatch Front, *Energy and Fuels.* 16: 282-293.

Long, R. W., Eatough, N. L., Mangelson, N. F., Thompson, W., Fiet, K., Smith, S., Smith, R., and Eatough, D. J., (2003). The Measurement of PM_{2.5}, Including Semi-Volatile Components, in the EMPACT Program: Results from the Salt Lake City Study and Implications for Public Awareness, Health Effects, and Control Strategies, *Atmos. Environ.* 37: 4407-4417.

Long, R. W., and McClenny, W. A., Laboratory and Field Evaluation of Instrumentation for the Semi-Continuous Determination of Particulate Nitrate (and other Water Soluble Components). Submitted to *J. Air & Waste Manage. Assoc.*

Meyer, M. B., Patashnick, H., and Ambs, J. L., (2002) Ongoing development of a continuous reference standard particulate matter mass monitor for ambient air, paper presented at the Symposium on Air Quality Measurement Methods and Technology, San Francisco, CA.

Mignacca, D., Stubbs, K. (1999). Effects of Equilibration temperature on PM₁₀ Concentrations from the TEOM Method in the Lower Fraser Valley. *J. of Air & Waste Manage. Assoc.* 49: 1250-1254.

Modey, W. K., Pang, Y., Eatough, N. L., and Eatough, D. J., (2001). Fine Particulate (PM_{2.5}) Composition in Atlanta, USA: Assessment of the Particle Concentrator Brigham Young University Organic Sampling System, PC-BOSS, During the EPA Supersite Study, *Atmos. Environ.* 35: 6493-6502.

Modey, W. K., Eatough, D. J. (2002). Trends in Composition at the Department of Energy OST NETL PM_{2.5} Characterization Site in Pittsburgh, Pennsylvania, USA. *Adv. Environ. Res.*, in press.

Musick, D. (2000). A Summary of the Ambient Air Program for PM_{2.5} *Environ. Manager.* 17-20.

Patashnick, H., Rupprecht, E. G. (1991). Continuous PM₁₀ measurements using the tapered element oscillating microbalance. *J. of Air & Waste Manage. Assoc.* 41: 1079-1083.

Pope, C.A. III (2000). Epidemiology of fine particulate air pollution and human health; Biological mechanisms and who's at risk? *Environ. Health Perspect.* 108(Sup 4): 713-723.

Pope, C. A. III, Hansen, M. L., Long, R. W., Nielson, K. R., Eatough, N. L., Wilson, W. E., Eatough, D. J. (2004). Particulate Air Pollution, HRV, and Inflammation. *Environ. Health Perspect.* 112: 339-345.

Schaefer, G., Hamilton, W., Mathai, C.V. (1997). Implementing the revised NAAQS and the FACA subcommittee for ozone, particulate matter and regional haze. *Environ. Manager*, 22-28.

Seinfeld, J. H.; and Pandis, S. N. (1996) *Atmospheric Chemistry and Physics*, John Wiley & Sons Inc, New York, 1996; pp 23-38.

Sioutas, C., Koutrakis, P., and Burton, R.M. (1994). Development and Evaluation of a Low Cutpoint Virtual Impactor. *Aerosol Sci. Technol.* 21: 223-235.

Schwartz, J., Dockery, D.W., Neas, L.M., (1996). Is daily mortality associated specifically with fine particles? *J. Air & Waste Manage. Assoc.* 46: 927-939.

Stolzenburg, M.R., and Hering, S.V., (2000). Method for the automated measurement of fine particulate nitrate in the atmosphere. *Environ. Sci. Technol.*, 34: 907-914.

Tang, H., Lewis, E. A., Eatough, D. J., Burton, R. M., and Farber, R. J. (1994). Determination of the particle size distribution and chemical composition of semi-volatile organic compounds in atmospheric fine particles. *Atmos. Environ.* 28: 939-947.

Turpin, B.J., and Lim, H.J. (2001). Species Contributions to PM_{2.5} Mass Concentrations: Revisiting Common Assumptions for Estimating Organic Mass. *Aerosol Sci. Technol.* 35: 602-610.

U.S. Environmental Protection Agency. 2002. Air Quality Criteria for Particulate Matter, Environmental Protection Agency, Research Triangle Park, NC, EPA/600/P-99/002aC.

Annual Estimates of Population for Incorporated Places over 100,000
<http://eire.census.gov/popest/data/cities/tables/SUB-EST2003-01.pdf> Accessed July 8, 2004.

Watson, J. G., Chow, J. C., Bowen, J. L., Lowenthal, D. H., Hering, S., Ouchida, P., and Oslund, W. (2000). Air quality measurements from the Fresno Supersite. *J. Air & Waste Manage. Assoc.* 50 (8): 1321-1334.

Watson, J. G., and Chow, J. C., (2002). A wintertime PM_{2.5} episode at the Fresno, CA, supersite. *Atmos. Environ.* 36(3): 465-475.

Watson, J. G. (2002). Visibility: Science and Regulation. *J. Air & Waste Manage. Assoc.* 52: 628-713.

Wilson W.E.; Suh, H.H. (1997). Fine Particles and Coarse Particles: Concentration Relationships Relevant to Epidemiologic Studies. *J. Air & Waste Manage. Assoc.* 47: 1238-1249.

Yi, S. M., Ambs, J. L., Patashnick, H., Rupprecht, G., Hopke, P. K., (2004) Evaluation of a prototype electrostatic precipitator (ESP) for a differential TEOM system, *Aerosol Sci. Technol.* Submitted.

Chapter 7. Measurement of PM_{2.5} Nonvolatile and Semi-Volatile Organic Material with the Sunset Laboratory Carbon Aerosol Monitor

7.1. Overview

Exposure to fine particulate matter (PM_{2.5}) has been implicated as a contributor to adverse human health effects including increases in cardiovascular and cardiopulmonary disease leading to elevated human mortality and morbidity (Pope, 2000; Pope *et al.*, 2004; Schwartz *et al.*, 1996). Carbonaceous material is a major component of urban fine particulate material. However, a significant portion of atmospheric carbonaceous material is often semi-volatile which tends to be lost from the collected particles during sample collection (Eatough, *et al.*, 2003). Diffusion denuder samplers (Eatough, *et al.*, 2003; Eatough, *et al.*, 2000) have been developed which allow for the determination of this fraction of the fine particulate carbonaceous material. The application of these samplers to the study of atmospheric chemistry in urban environments has shown that a substantial fraction of the fine particulate matter in these environments is SVOM (Obeidi, *et al.*, 2002; Long, *et al.*, 2002; Long *et al.*, 2003). Furthermore, these studies have shown that the majority of the semi-volatile organic material (SVOM) is secondary (Eatough, *et al.*, 2003; Long, *et al.*, 2003). Single filter samplers such as the PM_{2.5} FRM sampler and semi-continuous monitors such as the R&P carbon monitor or the Sunset Laboratory carbon aerosol monitor do not reliably sample and measure SVOM (Long, *et al.*, 2003; Anderson *et al.*, 2002). Because SVOM may be important with respect to human cardiovascular health effects (Pope, *et al.*, 2004), the development of reliable procedures for both the integrated and semi-continuous monitoring of this material is important.

SVOM in fine particles is not reliably measured with conventional semi-continuous carbon monitors because semi-volatile carbonaceous material is lost from the collection media during sample collection. We have modified a Sunset Laboratory carbon aerosol monitor to allow for the determination of SVOM. In the conventional Sunset monitor, the sampled air stream passes through a small denuder with charcoal impregnated cellulose filter (CIF) surfaces to remove gas phase organic compounds that can adsorb on the quartz filter and subsequently particles are collected on a quartz filter. However, some of the semi-volatile carbonaceous material (SVOC) is lost from the particles on the filter during collection, and therefore is not determined. Since the interfering gas phase organic compounds are removed prior to aerosol collection, the semi-volatile organic compounds lost from the filter can be determined by filtering the particles at the instrument inlet and then replacing the quartz filter in the monitor with a charcoal impregnated glass fiber filter (CIG) which retains the SVOM lost from particles collected on the inlet filter. The resulting collected SVOM is then determined in the analysis step by measurement of the carbonaceous material evolved from the CIG filter.

This chapter reports the modification of the Sunset Laboratory carbon aerosol monitor, which allows for the semi-continuous determination of carbonaceous material. This concept has been tested in experiments conducted in February, 2003, in Lindon, UT and in July, 2003, in Rubidoux, CA. Results obtained from the modified Sunset carbon monitor perpetuated the development of a dual-oven Sunset carbon monitor for the simultaneous measurement of both non-volatile and semi-volatile carbonaceous material. The dual-oven Sunset monitor was initially field tested during studies conducted at Lindon, UT from January to February, 2005 and in Riverside, CA during July-August,

2005. The results obtained have been validated by comparison with PC-BOSS results for nonvolatile carbonaceous material collected in an air stream denuded of gas phase organic material (OM) on a quartz filter and for semi-volatile carbonaceous material on a CIG filter after the quartz filter.

7.2. Experimental

7.2.1. Measurement of Nonvolatile Carbonaceous Material with a Conventional Sunset Monitor and Semi-Volatile Carbonaceous Material with a Modified Sunset Monitor, Utilizing a Common Inlet

The conventional Sunset instrument is a semi-continuous carbon aerosol analysis monitor and was described in Chapter 2. The inlet used was a 2.5 μm sharp cut cyclone (R&P) with a total flow of 16 L/min. Eight L/min of the flow was sampled by the conventional Sunset monitor and the remaining 8 L/min of flow was directed to the modified Sunset instrument as shown in Figure 7.1.

7.2.2. Sunset Monitor Modified to Measure Fine Particulate SVOC Lost from Particles During Sample Collection

A Sunset monitor was modified to allow for the determination of SVOC lost from particles during the 45-min sample collection period. The modified instrument sampled the second of the two split flow lines after the sharp cut cyclone inlet. A diffusion denuder, identical to that used in the unmodified instrument, removed gas phase material with an expected efficiency of better than 99%. After the removal of the gas material, the particles were removed from the sampled air stream immediately before the entrance to the Sunset monitor using a pre-fired (800 °C) 47-mm quartz filter in a MACE in-line, Teflon filter holder. The particle-free air, with any SVOC lost from the particles

Figure 7.1. Schematic of collocated conventional and modified Sunset monitors employing a common inlet.

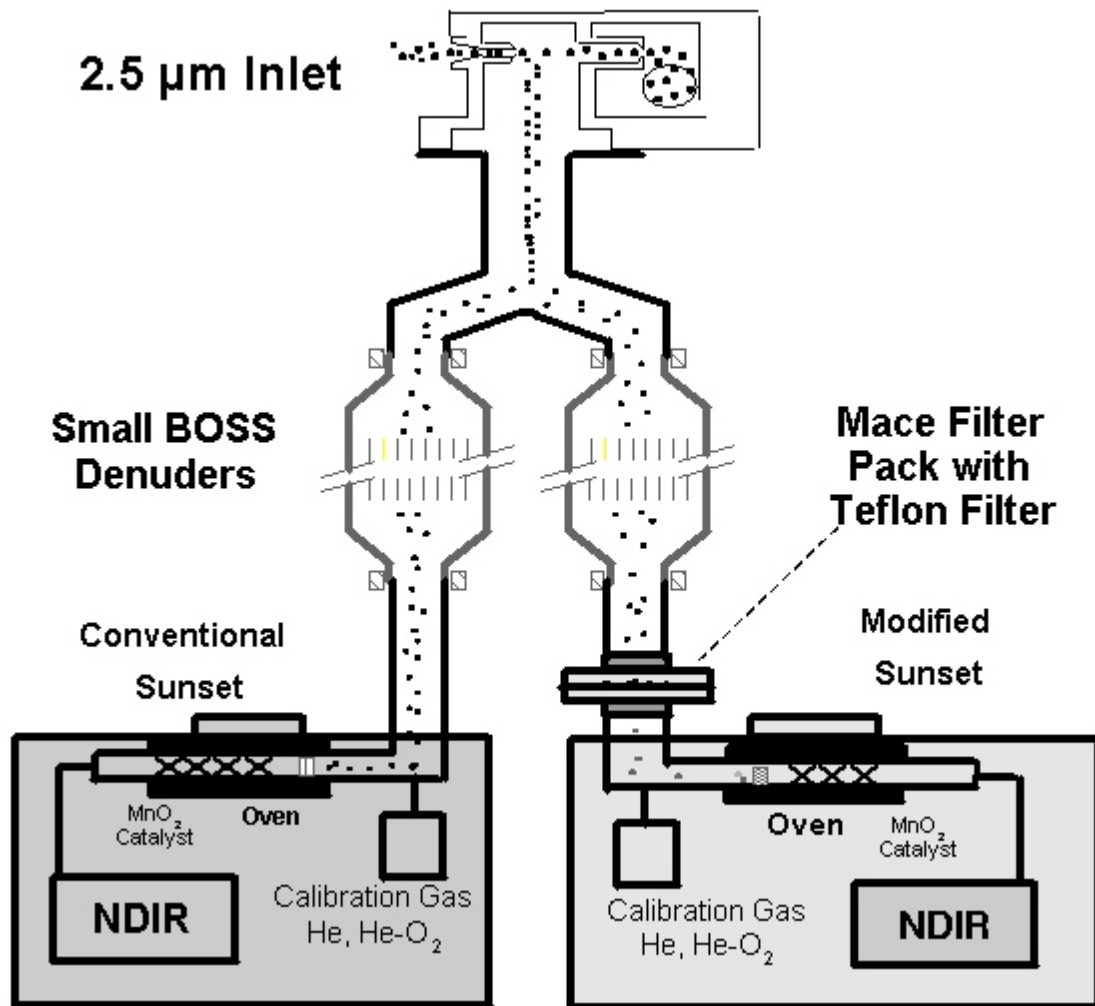

during sample collection, passed into the filter collection region of the modified Sunset monitor. The quartz filter normally used in the unmodified instrument was preceded by a charcoal impregnated glass fiber filter (CIG, Schleicher and Schuell, Dassell, Germany). The quartz filter was kept after the CIG to provide additional structural support for the CIG filter. Any SVOC lost from particles collected on the inlet quartz filter was collected with high efficiency by this CIG filter. At the end of the 45-min sample period, the SVOC collected on the CIG was analyzed by thermal evolution. This analysis was done in a three-step temperature program in a He atmosphere. Previous experience with the analysis of SVOC collected on CIG filters (Eatough *et al.*, 2003) has indicated that only lower molecular weight gas phase compounds are not removed by the diffusion denuder and that these organic compounds which “break through” the denuder are evolved from the CIG at temperatures below 200 °C. In contrast, the SVOC lost from particles are removed from the CIG at temperatures from about 250 to 350 °C. The first of the three temperature steps in the analysis of the SVOC involved heating to 190 °C to remove and measure the denuder breakthrough material. The second temperature step to 220 °C was to ensure that the breakthrough gas phase organic compounds had been cleanly removed. The final temperature step to 450 °C was to remove and measure the SVOC lost from the particles collected on the inlet quartz filter. This was followed by a calibration step for each analysis. The data obtained by this procedure are illustrated in Figure 7.2B. After the 15-min analysis and purge steps, sample collection was again initiated for the next 45-min period.

Figure 7.2. Measurement of (A) nonvolatile fine particulate carbonaceous material with a conventional Sunset Laboratory carbon aerosol monitor, and (B) SVOC lost from fine particles during sampling with a Sunset monitor modified as described in the text.

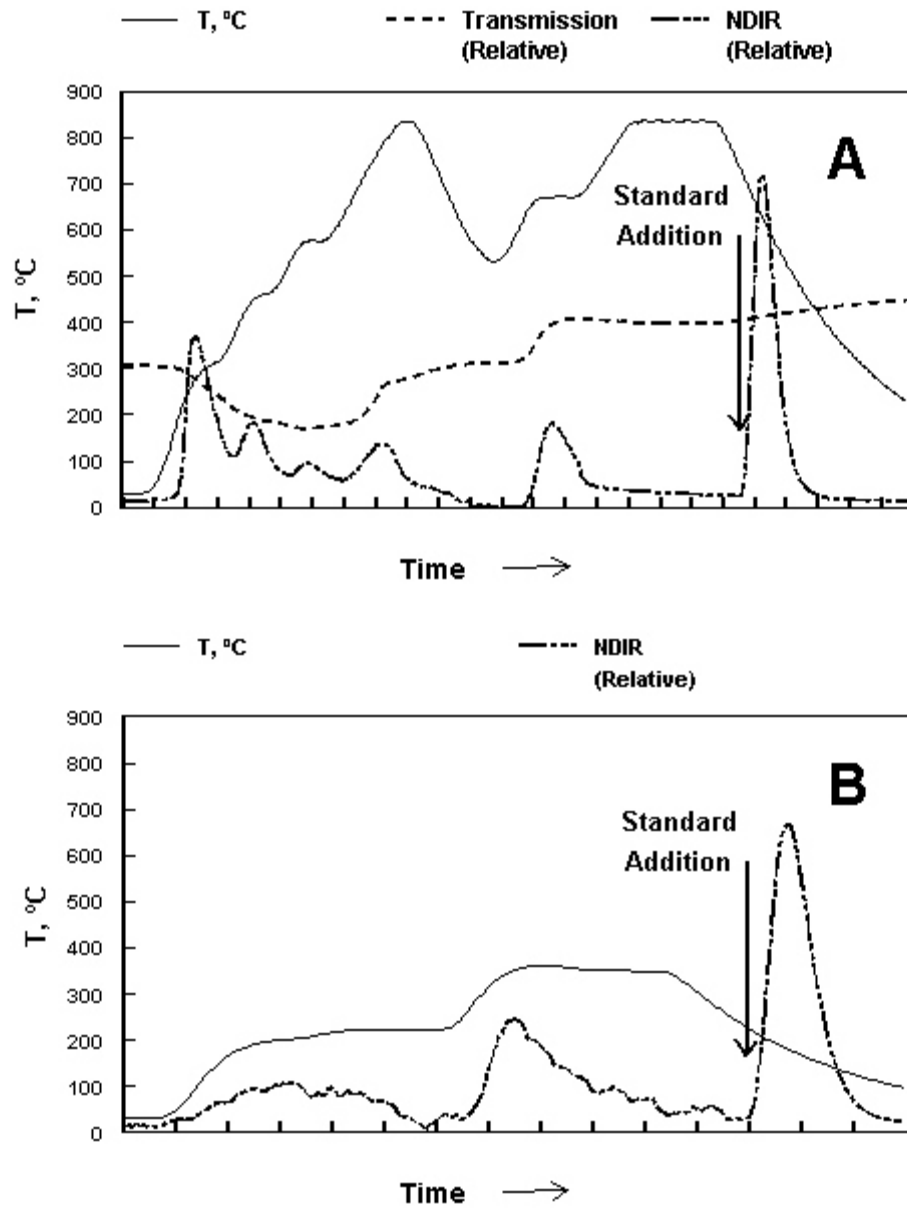

7.2.3. The Dual-Oven Sunset Monitor for the Simultaneous Measurement of Nonvolatile and Semi-Volatile Carbonaceous Material

Results obtained with the collocated Sunset monitors promoted the development of a dual-oven Sunset monitor. Ambient air was sampled at 8 L/min through a cyclone inlet with a 50% cutpoint of 2.5 μ m. A diffusion denuder, identical to that used in the conventional Sunset instrument, was used to remove gas phase material with an expected efficiency of better than 99%. The aerosol was subsequently sampled for 45-min on a quartz filter placed in the first oven with a dedicated catalyst and NDIR detector. The aerosol then passed through a CIG filter located in a second oven, placed in series, with a dedicated catalyst and NDIR detector. To retain structural rigidity, a CIG filter followed by a quartz filter was used in the second oven of the dual-oven Sunset monitor. SVOC lost from the quartz filter during sampling was subsequently collected with high efficiency on the CIG filter in the second oven. Following the 45-min collection period, a ball valve was switched, and each oven was isolated for analysis of the respective filters. Carbonaceous material collected on the quartz filter, in the first oven, was analyzed following the same protocols as the conventional Sunset monitor as described in Chapter 2. This analysis is shown in Figure 7.2A. The analysis of the CIG filter in the second oven was performed in a He atmosphere following protocols developed using the modified Sunset monitor as described above, i.e., see Figure 7.2B. Each sample analysis, on both filters, was followed by a standard addition of a known concentration of carbon for calibration of the respective NDIR detectors.

7.2.4. The PC-BOSS Sampler

Data obtained with the Sunset monitors was validated by comparison with PC-BOSS results. The PC-BOSS was used for sample collection to determine fine particulate mass, sulfate, carbonaceous material (elemental and organic), nitrate, SVOM, and semi-volatile nitrate as outline in Chapter 2. The quartz filter nonvolatile organic carbon (NVOC) and elemental carbon (EC), and CIG filter SVOC determined with the PC-BOSS were used for comparison with the results obtained with the two Sunset monitors. Temperature programmed volatilization (Eatough *et al.*, 2003; Ellis and Novakov, 1982) was used in the analysis of PC-BOSS collected samples for total carbonaceous material as outline in Chapter 2.

7.2.5. Sample Collection

Initial studies using conventional and modified Sunset monitors with a common inlet were conducted in February, 2003 in Lindon, UT. The Lindon sampling site has been previously described in Chapter 3. In these experiments, results obtained with the modified Sunset monitor were compared to fine particulate SVOC determined in 6-h integrated samples with the PC-BOSS. More extensive studies were conducted during July 2003 at the South Coast Air Quality Monitoring District (SCAQMD) sampling site in Rubidoux, CA as described in Chapter 4. In these experiments, both the conventional and modified Sunset monitors were simultaneously used. Results were compared with 3-h integrated PC-BOSS sample results.

The dual-oven Sunset monitor was initially tested during January-March 2005 at the Lindon, UT sampling site. These studies were used to determine sampling protocols, blank evaluations and comparisons with 3-h PC-BOSS data. The dual-oven instrument

was extensively tested in studies conducted in Riverside, CA during July-August, 2005 at the Riverside sampling site described in Chapter 9. Comparisons were made for both nonvolatile carbon, collected on the quartz filter, and SVOC, collected on the CIG filter, with 3-h PC-BOSS nonvolatile carbon and SVOC measurements. Furthermore, total carbon (TC), nonvolatile plus semi-volatile, comparisons were made with 3-h PC-BOSS data.

7.3. Results and Discussion

7.3.1. Efficiency of the Sunset Monitor Denuder for Removal of Gas Phase Organic Material

The analysis of material collected by the CIG filter in the modified Sunset instrument is illustrated in Figure 7.2B. The initial peak in the data is due to the small fraction of the gas phase organic material entering the denuder which is not removed by the denuder. For the sample given in Figure 7.2B, this initial peak is about half the size of the larger peak in the 220 - 450 °C temperature step. The gas phase organic material collected on the side-flow filter of the PC-BOSS is a measure of the total gas phase organic material which enters the diffusion denuder of the Sunset instrument. The initial peak in Figure 7.2B is the amount of this total which is not removed by the denuder. Initially the efficiency of the denuder was better than 99.5%. However, as observed in the data obtained over a three week period in Lindon, the size of the first peak, relative to the SVOC peak, increases with time as the efficiency of the denuder drops to about 98% over this time period. The data illustrated in Figure 7.2B are after about 2 weeks of sampling with the denuder. To help maintain high denuder efficiency, new charcoal impregnated cellulose fiber filter strips (Schleicher and Schuell) were placed in the

denuder about every ten days during the Lindon study. These strips are cut to size for the denuder box and used without further treatment as received from the manufacturer.

Denuder strips were not changed during the Rubidoux study.

7.3.2. Determination of Fine Particulate SVOC and Nonvolatile Carbon with the Collocated Sunset Monitors Employing a Common Inlet

The two Sunset monitors employing a common inlet used at Rubidoux were intended to allow for the semi-continuous measurement of total fine particulate carbonaceous material; nonvolatile material (including elemental carbon) was determined by the instrument with the quartz filter and fine particulate SVOC was determined by the instrument with the CIG filter. The data obtained with the modified Sunset instrument using a CIG filter is illustrated in Figure 7.2B and has been discussed in the proceeding section. Typical data obtained with the conventional Sunset monitor are illustrated in Figure 7.2A. As shown, the organic carbonaceous material is initially evolved in four temperature steps in a He atmosphere. Any pyrolyzed carbon and EC are then removed in an O₂/He atmosphere, with the amount of EC identified from the point at which the measured laser absorbance returns to the original value for the sample. While the data obtained with the Sunset instrument will allow determination of the amount of carbon evolved in each of the temperature steps and the identification of the concentrations of EC, only total carbonaceous material is used in the comparisons made with the collocated Sunset monitors employing a common inlet.

The concentrations of nonvolatile and semi-volatile carbonaceous material determined with the two instruments are illustrated with concentrations determined over a 7-day period in the Rubidoux study in Figure 7.3. As illustrated, the results indicate

Figure 7.3. Concentrations of nonvolatile fine particulate carbonaceous material determined with a conventional Sunset Laboratory carbon aerosol monitor, and SVOC lost from the collected fine particles during sampling determined with a Sunset monitor modified as described in the text.

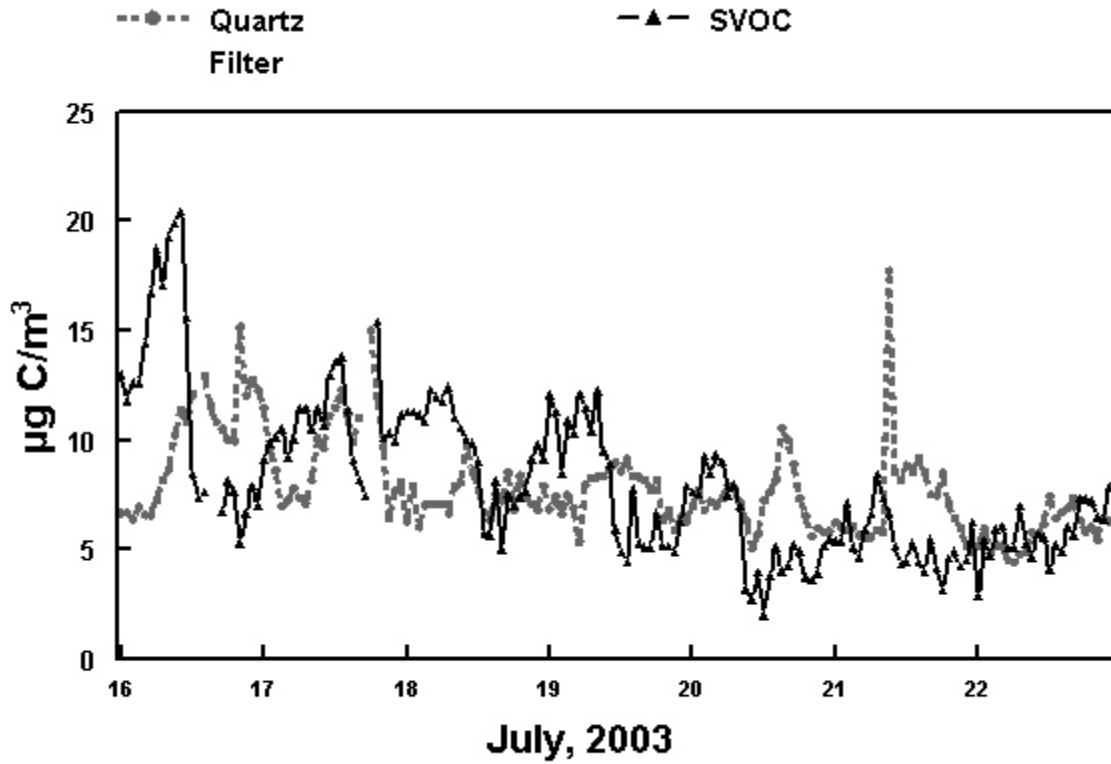

that SVOC was a significant fraction of the total fine particulate material during the study. Concentrations of SVOC and nonvolatile quartz filter carbon were both high, and they showed strong, but different, diurnal patterns during the first four days of this period. Concentrations were much lower during the last two days.

The accuracy in the measurement of SVOC, NVOC and total PM_{2.5} carbon, as illustrated by the data in Figure 7.3, can be evaluated by comparison of the measurement obtained with the modified Sunset instrument and the SVOC, NVOC and total PM_{2.5} carbon measured using the PC-BOSS, as described above. These two measurements for each species are compared for the 3-h integrated time periods over which the PC-BOSS measurements were made in Figure 7.4, and the linear regression statistics are given in Table 7.1. The larger number of data point for SVOC results from two time periods when the conventional Sunset monitor (NVOC quartz data) was not operating properly. As illustrated, measurements for total PM_{2.5} carbon made by the two instruments agreed. Linear regression analysis of the data given in Figure 7.4 (N = 21, R² = 0.92) gives a zero intercept slope of 0.99 ± 0.02 . The slope obtained with a fit intercept is similar, 0.90 ± 0.06 . The precision of the comparison is $\sigma = \pm 1.5 \mu\text{g C/m}^3$ (8.0%) and the average measured concentration of PM_{2.5} carbon is $18.8 \mu\text{g C/m}^3$, with no bias between the two measurements. The precision of the comparison is similar to the expected precision of the PC-BOSS 3-h integrated measurement of $\pm 1\text{-}2 \mu\text{g PM}_{2.5} \text{ C/m}^3$, based on the blank filter reproducibility and the uncertainty in the PC-BOSS flow data. Thus, this comparison indicates that the PM_{2.5} carbon measurements by the two independent techniques are equivalent. During the time period when SVOC was measured, the SVOM (assuming SVOM was 62% carbon, Turpin and Lim, 2001) averaged 21% of the

Figure 7.4. Comparison of SVOC, NVOC and PM_{2.5} C measured with a Sunset monitor modified as described in the text and 3-h integrated data measured with a PC-BOSS.

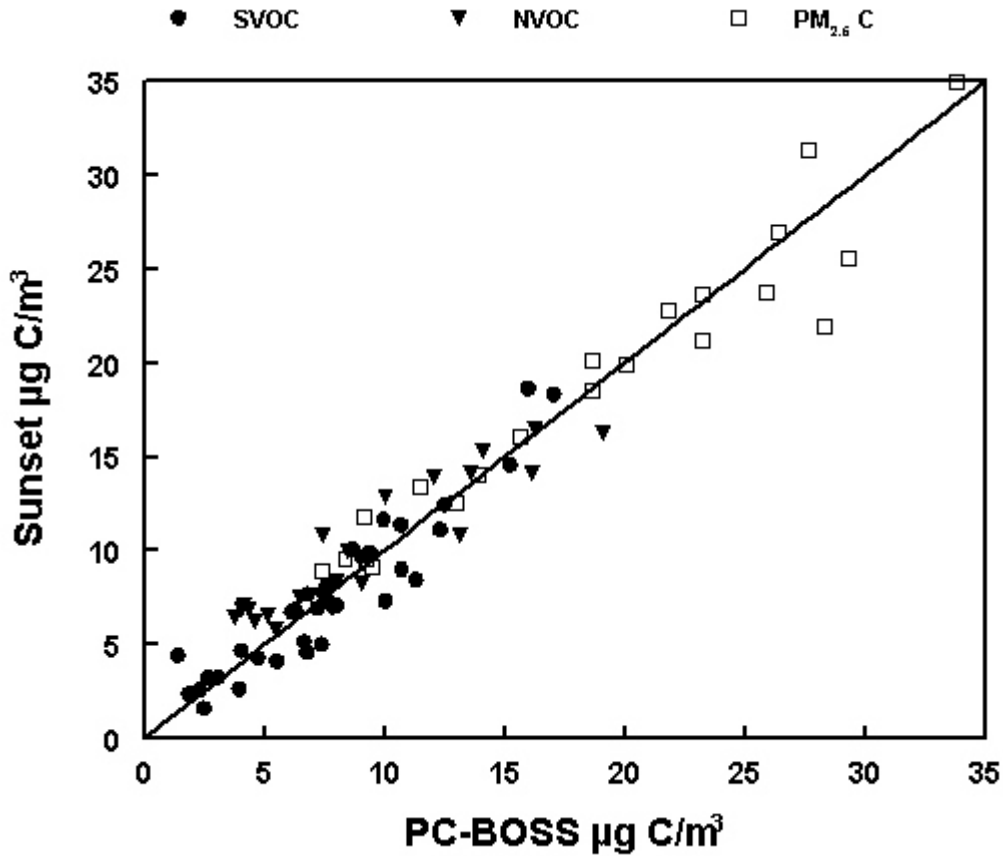

Table 7.1. Linear Regression Statistics of PC-BOSS and Sunset Comparisons Including TC, SVOC, and NVOC in Rubidoux, CA with Collocated Sunset Monitors Employing a Common Inlet.

X vs Y	n	R ²	Slope ^a	Intercept g C/m ³	X Average g C/m ³	X-Y Bias g C/m ³	g C/m ³	%
Rubidoux, CA								
PC-BOSS Total C vs. Sunset Total C	21	0.92 0.93	0.99 ± 0.02 0.90 ± 0.06	0 2.0 ± 2.1	18.8	0.0	1.5	8.0
PC-BOSS SVOC vs. Sunset SVOC	34 ^b	0.89 0.89	0.99 ± 0.03 0.99 ± 0.06	0 -0.1 ± 1.4	7.7	0.1	1.0	12.9
PC-BOSS NVOC vs. Sunset NVOC	21	0.70 0.88	1.03 ± 0.04 0.73 ± 0.06	0 3.4 ± 1.3	9.2	-1.0	1.4	14.4
Lindon, UT								
PC-BOSS NVOC vs. Sunset NVOC	16	0.58 0.71	0.91 ± 0.08 0.67 ± 0.12	0 2.1 ± 1.9	6.2	-0.1	1.6	25.9
Riverside, CA								
Sunset TC vs PC-BOSS TC ^d	30	0.63 0.63	0.93 ± 0.03 0.92 ± 0.13	0 0.1 ± 1.8	10.6	0.8	1.4	13.0
Chamber Experiments								
PC-BOSS Total C vs Sunset Total C	5	0.99 0.99	1.12 ± 0.01 1.08 ± 0.06	0 11.4 ± 10.4	280.4	-33.4	NA ^c	NA ^c

^aSlopes are given for (1) zero intercept and (2) calculated intercept

^bMore data points were obtained for SVOC comparisons due to two time periods when the conventional Sunset monitor was unreliable

^c and % were not calculated for the chamber experiments due to large bias between the two sampling techniques

^d Five statistical outliers were removed in the linear regression analysis

total PM_{2.5} as measured by an R&P FDMS TEOM (Grover, *et al.*, 2005). Comparisons can also be made between the carbonaceous material determined on either the quartz filter (NVOC) of the conventional Sunset instrument, or the CIG (SVOC) filter of the modified Sunset instrument and the corresponding quartz or CIG filter of the PC-BOSS. Complete linear regression statistics for SVOC and NVOC between the PC-BOSS (x) and the Sunset (y) are given in Table 7.1. As indicated by the data, there was a bias of 0.1 µg/m³ in the PC-BOSS, compared to the Sunset SVOC data and an opposite bias of -1.0 µg/m³ for the NVOC data for the data points given. These two opposite biases indicate that the extent of loss of SVOC from the quartz filter was slightly larger for the PC-BOSS, compared to the Sunset filters. This may reflect the higher flow rate and/or the longer sampling time period in the PC-BOSS instrument.

7.3.3. Evaluation of the Dual-Oven Sunset Monitor for the Simultaneous Measurement of Nonvolatile and Semi-Volatile Carbonaceous Material

Blank Measurements. Because the ultra-pure He analysis gas used in the Sunset monitor may contain sub-ppb levels of oxygen, resulting in the loss of carbon from the CIG collection filter under analysis conditions, blank measurements were made to determine if a blank correction was necessary. Blank correction measurements were made in Lindon, UT during February, 2005.

Ambient air was sampled through a Teflon filter, in an in-line MACE filter pack, placed at the inlet of the sample stream. The aerosol then passed through the diffusion denuder to remove gas phase species and was subsequently directed to the dual-oven Sunset instrument for analysis. Thirty-min collection cycles were used, and the quartz filter (NVOC) blank data and CIG filter (semi-volatile carbon, SVC) blank data are

shown in Figure 7.5. The average blank concentrations (n=27) were 0.61 and 0.50 g carbon for NVOC and SVC, respectively.

To avoid decreased denuder efficiency caused by the decrease in pressure drop through the denuder, as the result of the Teflon filter at the sampling inlet, a second blank configuration was tested. Ambient air was sampled through a diffusion denuder similar to the one used on the Sunset instrument to remove gas phase species with an expected efficiency of greater than 99% (Eatough *et al.*, 1999). The aerosol then passed through the Teflon filter to remove particles, and subsequently was directed through a second diffusion denuder to guarantee the removal of all gas phase species. The air sample was then directed to the dual-oven Sunset instrument for analysis employing 30-min collection cycles. Average concentrations (n=25) of 0.52 and 0.45 g carbon were obtained for NVOC and SVC, respectively, with blank data shown in Figure 7.5.

A zero-min collection blank was also performed. The dual-oven Sunset analysis was repeatedly performed without any sample collection. The average concentrations (n=115) for the zero-min collection blank were 0.25 g carbon for NVOC collected on the quartz filter and 0.35 g carbon for SVC collected on the CIG filter. A representative sample of zero-min collection blank data is shown in Figure 7.5. In the study conducted in Riverside, CA, during July-August, 2005, it was determined that the amount of carbon lost from the CIG filter could be reduced by decreasing the maximum temperature reached to approximately 360 °C in the final temperature step of the CIG analysis. Because semi-volatile carbon is expected to be removed from the CIG filter in

Figure 7.5. Dual-oven blank concentrations measured with three different blank configurations in Lindon, UT.

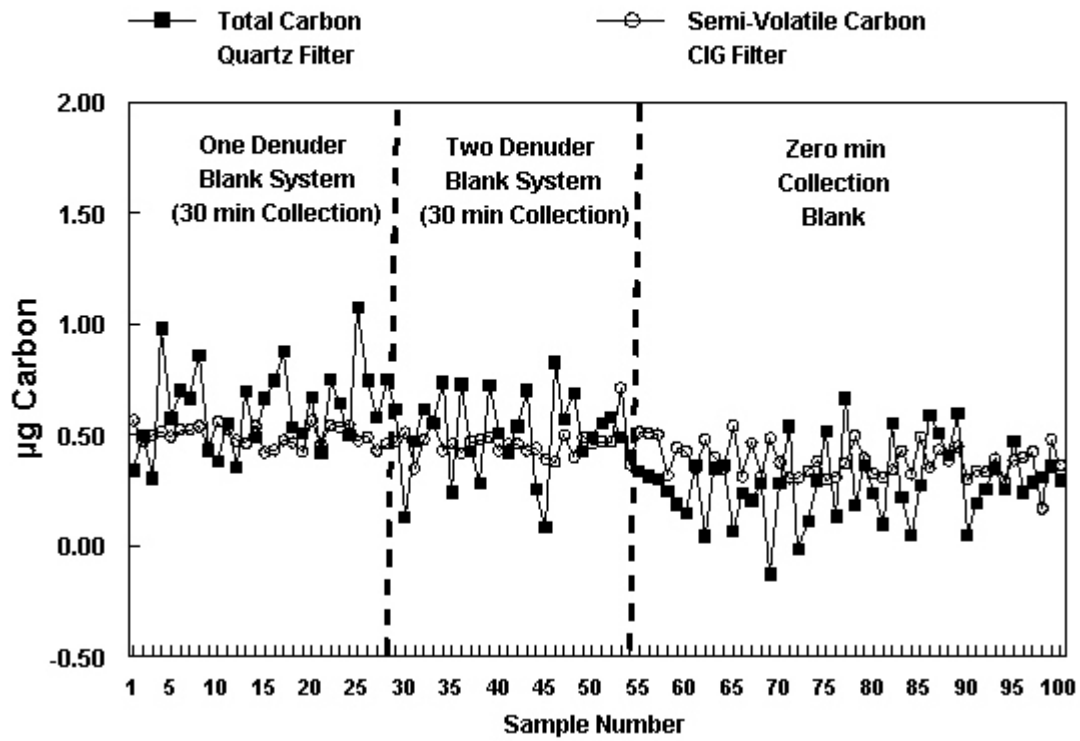

the temperature range of 220-350 °C (Eatough *et al.*, 2003), the reduction in temperature was not observed to result in incomplete desorption of semi-volatile carbonaceous species from the CIG filter. Furthermore, NDIR response returned to baseline conditions prior to cooling the CIG filter, indicating that complete desorption of semi-volatile species occurred from the CIG filter. Under these analysis conditions, the average zero-min blank concentrations (n=14) were 0.71 and 0.14 g carbon for NVC and SVC, respectively.

7.3.4. Ambient Data Lindon, UT

Generally, concentrations of PM_{2.5} were low throughout the Lindon, UT study with average PM_{2.5} mass concentrations of 23.2 g/m³ and 5.2 g/m³ measured by the FDMS and TEOM monitors, respectively. Three-h PC-BOSS samples were collected for several time periods during the study. However during the majority of the study, problems associated with the CIG oven did not allow for comparison of semi-volatile carbon measurements with PC-BOSS data. Comparisons were possible with quartz filter data from the dual-oven Sunset monitor and 3-h quartz filter data from the PC-BOSS with linear regression statistics for NVOC concentrations given in Table 7.1. Even though NVOC concentrations were low during the study, generally good agreement was observed between the PC-BOSS and dual-oven Sunset monitor data with an uncertainty in the comparison of ± 1.6 g/m³. Although the data scattered around the one-to-one line, because of the low concentrations during the study the correlation coefficients were not as high as expected, as shown in Table 7.1.

Because SVOM concentrations were low during the Lindon, UT study, the dual-oven Sunset monitor was employed without the use of a diffusion denuder in the sampling stream, to remove gas phase species from the aerosol, to validate the collection of ambient carbonaceous material on the CIG filter in the second oven of the sampler. One-h collection periods were performed for 20-h without the denuder, and then the instrument was returned to normal operation. For the time period without a denuder in the sample stream, concentrations of carbon evolved from the third temperature regime (220 - 450 °C) of the CIG filter accounted for 73% of the total carbon concentration (NVOC + carbon evolved from the third temperature step of the CIG filter) with an average concentration of 11.5 g C/m³. When the denuder was replaced in the sample stream, carbon evolved from the third temperature step accounted for 58% of the total carbon concentration with an averaged concentration of only 3.2 g C/m³. However, concentrations of carbonaceous material evolved from the first two temperature steps of the CIG filter oven (~25 - 220 °C) remained constant with average concentrations of 4.8 g C/m³ for time periods without and with a denuder. Average NVOC concentrations measured on the quartz filter of the dual-oven Sunset were 4.2 and 2.3 g C/m³ for time periods without and with a denuder, respectively. Some of the increase in average NVOC concentrations for the time periods without a denuder are most likely due to the collection of gas phase organic species on the quartz filter in the dual-oven instrument. However, the amount of gas phase organic species collection by the quartz filter cannot be quantified.

7.3.5. Ambient Data Riverside, CA

The dual-oven Sunset monitor was extensively field tested for the first time in Riverside, CA during July-August, 2005. Forty-five-min collection cycles were used with 15-min analysis periods during the study. Concentrations of NVOC, EC, and SVOC are shown in Figure 7.6. Average concentrations of NVOC and EC for the study period were 8.2 g/m^3 and 2.5 g/m^3 , respectively. NVOC concentrations exhibited a distinct diurnal pattern throughout the study with peak concentration periods occurring during daytime periods. Furthermore, NVOC weekend concentrations were similar to those observed on weekdays. A distinct diurnal pattern was also observed in EC concentrations with peak concentrations observed during the morning hours. However, on weekends significant increases of EC concentrations in the morning time period were not observed. This diurnal EC pattern correlates well with local traffic emissions. The dual-oven Sunset monitor responded to short-term changes observed in NVOC and EC throughout the study.

SVOC concentrations measured by the CIG filter in the second oven of the dual-oven Sunset monitor are also shown in Figure 7.6. Generally, SVOC concentrations were low throughout the study period. Several episodes of SVOC occurred when SVOC concentrations peaked near 5 g/m^3 during mid-day time periods. Otherwise, slightly increased concentrations of SVOC were observed when photochemical activity peaked during daylight periods with lower concentrations observed during nighttime periods. The formation of SVOC is thought to be associated with photochemical reactions in the atmosphere (Eatough *et al.*, 2003), and increased concentrations would be expected

Figure 7.6. Dual-oven Sunset monitor concentrations of NVOC, EC, and SVOC during July-August, 2005 in Riverside, CA.

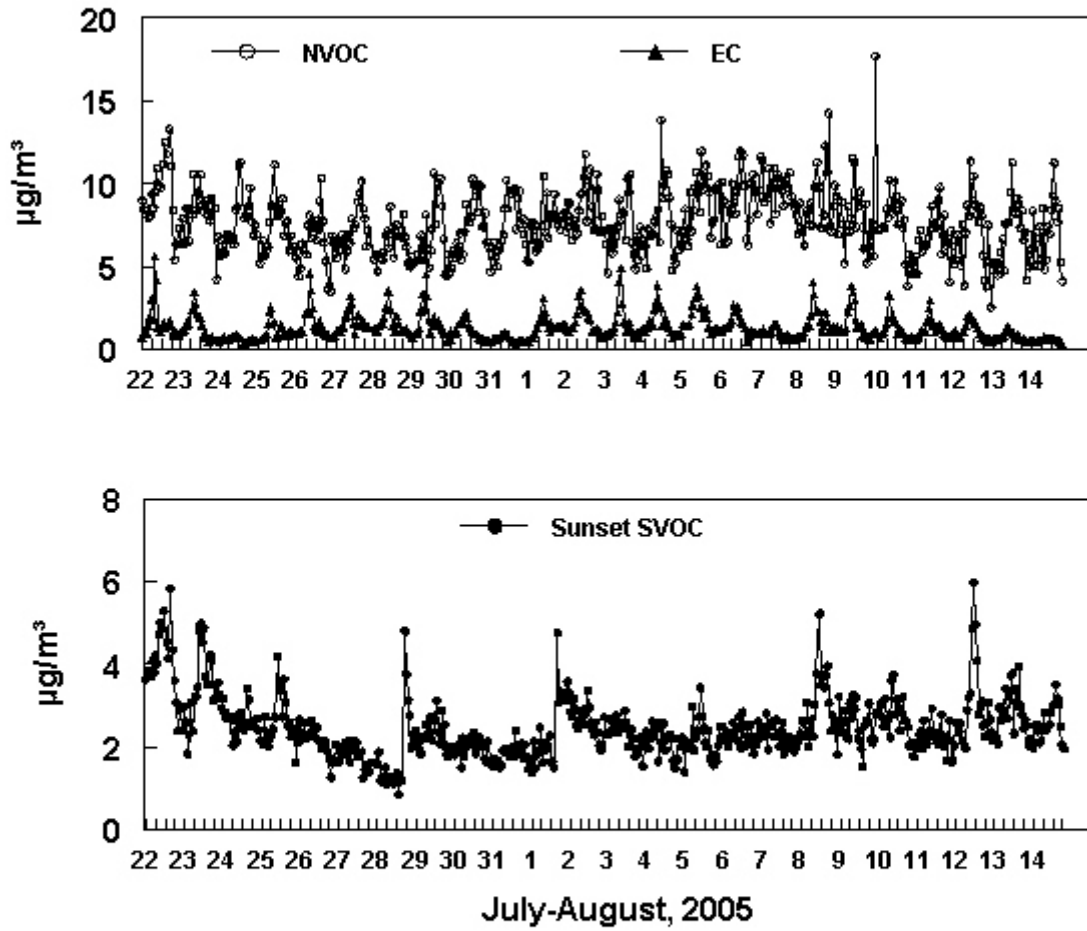

during periods of high photochemical activity. Although concentrations of SVOC were low throughout the study period, the dual-oven Sunset monitor responded to short-term changes in ambient SVOC concentrations.

Three-h PC-BOSS samples were collected on several days during the Riverside, CA study. Dual-oven Sunset concentrations were averaged over the 3-h PC-BOSS time periods. Because of the different flow rates used in the dual-oven Sunset monitor and the PC-BOSS, the most meaningful comparison between the two sampling techniques is to compare TC, nonvolatile plus semi-volatile, concentrations as shown in Figure 7.7. Linear regression statistics for a TC comparison are given in Table 7.1. Five statistical outliers were removed from the comparison. Good agreement was observed for TC concentration values with zero intercept slope of 0.93 ± 0.03 and an uncertainty of $\pm 1.4 \text{ g C/m}^3$ or 13%. The measured uncertainty is within the range of the expected uncertainty of the PC-BOSS measurement, indicating that the dual-oven Sunset monitor can be used to accurately measure ambient TC, including SVOC.

OC and EC concentrations can be converted to OM and SVOM by a conversion factor of 1.4, typical of an aged urban aerosol (Turpin and Lim, 2001). In this study, OM and SVOM constituted 41% and 12%, respectively, of the total $\text{PM}_{2.5}$ mass as measured by an R&P FDMS monitor.

7.3.6. Chamber Experiments with the Dual-Oven Sunset Monitor

The dual-oven Sunset monitor was evaluated by sampling wood smoke emissions from an indoor environmental sampling chamber. The indoor Teflon chamber is described in Chapter 9. Wood smoke was sampled from the flue line of a certified wood

Figure 7.7. Comparison of dual-oven Sunset and PC-BOSS TC (NVOC + SVOC) for the study conducted in Riverside, CA, during July-August, 2005. Five statistical outliers ($> 3\sigma$) were removed shown in squares in the figure.

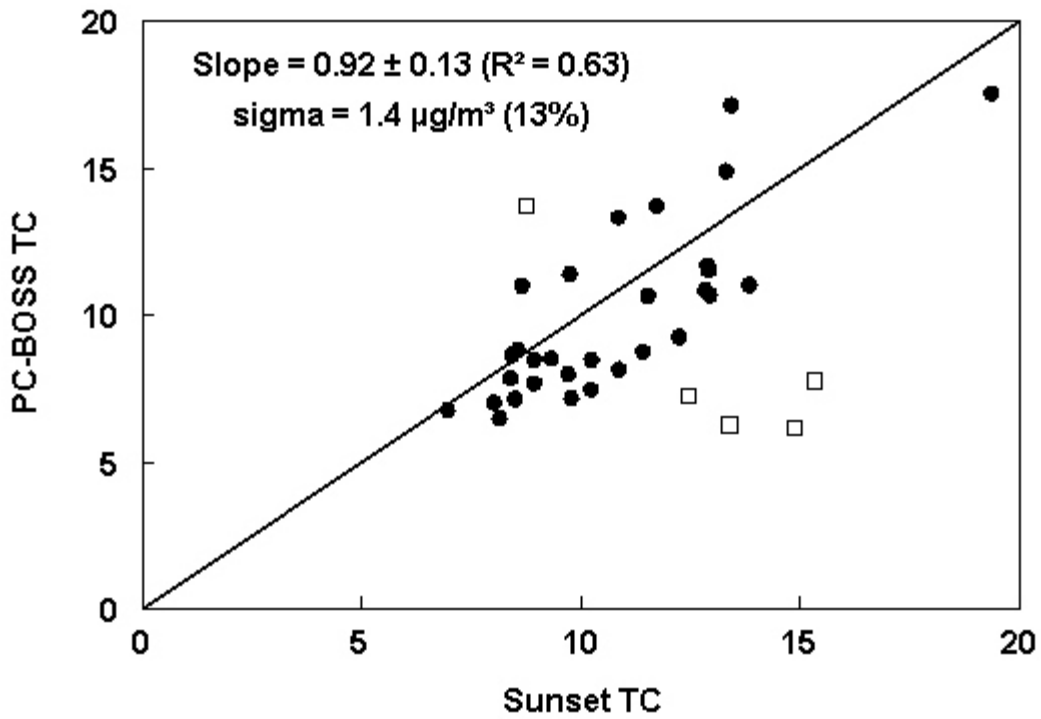

burning stove and introduced into the Teflon chamber and allowed to equilibrate. A dedicated UV/black light system was constantly employed to simulate ambient light to induce photochemical reactions following protocols described in Chapter 9. Thirty-min sampling cycles were performed with the dual-oven Sunset monitor and a BOSS sampler.

The BOSS sampler consisted of a diffusion denuder, previously described in Chapter 2, and similar to the denuder used in the dual-oven Sunset monitor. The aerosol was directed through the BOSS denuder and subsequently collected on a quartz filter followed by a carbon impregnated (CIG) glass-fiber filter identical to those used in the PC-BOSS. These filters were analyzed by temperature programmed volatilization (TPV) for the determination of NVOC and SVOC as described in Chapter 2. Comparisons were made between NVOC, SVOC and TC (NVOC + SVOC) concentrations determined by the dual-oven Sunset monitor and the BOSS sampler.

Two sampling configurations were used in comparisons between the two sampling systems. First, both samplers were operated under standard operating protocols with both samplers employing diffusion denuders to remove gas phase species prior to analysis. The concentrations of NVOC, SVOC, and TC for three 30-min collection cycles collected during the chamber experiment are given in Table 7.2. The average concentrations for the three 30-min collection cycles of NVOC, SVOC, and TC were 226.9 g C/m³, 111.5 g C/m³, 339.4 g C/m³ and 375.8 g C/m³, 2.6 g C/m³, 378.3 g C/m³ for the BOSS and the dual-oven Sunset monitor, respectively. The concentrations of SVOC measured by the BOSS sampler were significantly greater than those measured by the dual-oven Sunset monitor. However, NVOC concentrations measured by the

Table 7.2. Dual-Oven Sunset Monitor Chamber Experiment Results.

PC-BOSS			Sunset		
OC+EC g/m ³	SVOC g/m ³	Total C g/m ³	OC+EC g/m ³	SVOC g/m ³	Total C g/m ³
With Denuder			With Denuder		
235.6	106.1	341.7	366.1	3.2	369.3
227.0	117.6	344.6	382.8	1.4	384.2
218.2	113.6	331.8	378.3	3.2	381.5
(1) No Denuder (2) With Denuder			No Denuder		
126.6 117.0	66.2 2.0	192.8 118.9	166.2	47.6	213.8
126.5 121.3	64.6 0.3	191.2 121.6	168.1	55.0	223.1

BOSS sampler were much lower than those measured by the dual-oven Sunset monitor. This is presumably due to the difference in flow rates between the two samplers, with much more SVOC lost from the quartz collection filter of the BOSS sampler as the result of the higher flow rate. Furthermore, average TC concentrations resulted in a bias of the dual-oven Sunset monitor measuring an average of 40.0 g C/m^3 greater than the BOSS sampler. Because of the high concentrations of particulate carbon in the chamber experiments, the NDIR response of the dual-oven samples were of similar magnitude to the calibration peaks, which may explain some of the bias between the two sampling techniques.

A second sampling configuration was also used in the chamber experiments. Wood smoke was sampled from the Teflon chamber by the dual-oven Sunset monitor without the use of the in-line diffusion denuder to remove gas phase species. Simultaneous BOSS samples were also collected both with and without in-line diffusion denuders. Concentrations of NVOC, SVOC, and TC are given in Table 7.2. A similar pattern of measured concentrations as those observed in the previous chamber experiment were observed. The average concentrations for the two 30-min collection cycles of NVOC, SVOC, and TC were 126.6 g C/m^3 , 65.4 g C/m^3 , 192.0 g C/m^3 and 119.2 g C/m^3 , 1.2 g C/m^3 , 120.3 g C/m^3 for the BOSS without a denuder and a BOSS with a denuder, respectively. Average NVOC, SVOC, and TC concentrations measured by the dual-oven Sunset monitor without a denuder were 167.1 g C/m^3 , 51.3 g C/m^3 , and 218.4 g C/m^3 , respectively. SVOC concentrations determined by the dual-oven Sunset monitor without a denuder are much larger than those observed when a denuder is

employed because of the highly efficient collection of gas-phase organic species by the CIG filter. The dual-oven Sunset monitor measured an average TC concentration of 26.4 g C/m³ greater than the BOSS sampler operating under a similar no denuder configuration. A complete understanding of the difference observed between the two sampling techniques under elevated particulate carbon concentrations is not known at this time. Linear regression statistics for the five sampling cycles when both instruments were operating under similar sampling conditions are given in Table 7.1.

An estimate of the dual-oven Sunset monitor denuder efficiency was evaluated by comparing the concentration of SVOC measured by the dual-oven Sunset monitor operating without a denuder and the BOSS sampler operating with a denuder. Even at the elevated concentrations of particulate carbon in the chamber experiments, the denuder efficiency was estimated at 98% efficient for removing gas-phase organic species.

7.4. Conclusions

The data presented in this chapter indicate that the Sunset Laboratory carbon aerosol monitor can be modified to allow for the routine semi-continuous determination of semi-volatile carbonaceous components in ambient fine particulate material. The modification consists of filtering particles at the inlet to the instrument so that only the SVOC lost from particles is collected on the filter of the monitor and using a CIG filter to capture these SVOC. This modification is straightforward for the existing Sunset monitor, and should allow for the facile determination of this fine particulate species in the future. The data obtained with the modified instrument at Rubidoux in July indicate

that SVOC averaged 21% of the total PM_{2.5} at this location as measured by the R&P FDMS monitor.

Validation studies with the dual-oven Sunset monitor indicated that 1-h average concentrations of SVOC, NVOC, and TC can be measured. At normal ambient carbon concentrations, the efficiency of the diffusion denuder was greater than 99%. Good agreement for TC was obtained between PC-BOSS and dual-oven Sunset monitor results in Riverside, CA indicating that the dual-oven instrument can accurately measure ambient carbonaceous material. However, at elevated concentrations observed in chamber experiments, dual-oven Sunset monitor results for TC were consistently slightly higher than BOSS results, possibly due to the high concentrations observed resulting in non-linear NDIR response.

7.5. References

Anderson, R.R., Martello, D.V., Rohar, P.C., Strazisar, B.R., Tamilia, J.P., Waldner, K., White, C.M., Modey, W.K., Mangelson, N.F., Eatough, D.J. (2002). "Sources and Composition of PM_{2.5} at the National Energy Technology Laboratory in Pittsburgh During July and August 2000," *Energy and Fuels*, 16(2): 261-269.

Birch, M. E.; Cary, R. A. (1996). Elemental carbon-based method for occupational monitoring of particulate diesel exhaust: methodology and exposure issues. *Analyst* 121: 1183-1190.

Carter, C.B., Long, R.W., Eatough, N.L., Eatough, D.J. (2002) "Comparison of Speciation Sampler and PC-BOSS PM_{2.5} Organic Material Results Obtained on the Wasatch Front During the Winter of 2001-2002," *Proceeding of the AWMA 2002 Annual Conference*, Paper #42675.

Ding, Y., Pang, Y., Eatough, D.J., (2002) "High volume diffusion denuder sampler for the routine monitoring of fine particulate matter: I. Design and optimization of the PC-BOSS," *Aerosol Sci. Technol.*, 36: 369-382.

Eatough, D.J., Obeidi, F., Pang, Y., Ding, Y., Eatough, N.L., Wislon, W.E. (1999). Integrated and real-time diffusion denuder sampler for PM_{2.5}. *Atmos. Environ.* 33: 2835-2844.

Eatough, D.J., Eatough, N.L., Obeidi, F., Pang, Y., Modey, W., Long, R. (2000) "Continuous determination of PM_{2.5} mass, including semi-volatile species," *Aerosol Sci. Technol.*, 34: 1-8.

Eatough, D.J., Long, R.W., Modey, W.K., Eatough, N.L. (2003), "Semi-volatile secondary organic aerosol in urban atmospheres: meeting a measurement challenge," *Atmos. Environ.*, 37: 1277-1292.

Ellis, E.C. and Novakov, T. (1982) "Application of thermal analysis to the characterization of organic aerosol particles," *Sci. Total Environ.*, 23.

Grover, B .D., Kleinman, M. A., Eatough, N. L., Eatough, D. J., Hopke, P. K., Long, R. W., Wilson, W. E., Meyer, M. B., Ambs, J. L. (2005) Measurement of Total PM_{2.5} Mass (Nonvolatile plus Semi-Volatile) with the FDMS TEOM Monitor. *J. Geophysical Research*, 110, D07S03.

Lewtas, J., Booth, D., Pang, Y., Reimer, S., Eatough, D.J., Gundel, L. (2001) "Comparison of sampling methods for semi-volatile organic carbon (SVOC) associated with PM_{2.5}," *Aerosol Sci. Technol.*, 34.

Long, R.W., Smith, R., Smith, S., Eatough, N.L., Mangelson and Eatough, D.J. (2002) Sources of Fine Particulate Material along the Wasatch Front, *Energy and Fuels*. 16: 282-293.

Long, R.W., Eatough, N.L., Mangelson, N.F., Thompson, W., Fiet, K., Smith, S., Smith, R., Eatough, D.J., Pope, C.A., Wilson, W.E. (2003). "The Measurement of PM_{2.5}, Including Semi-Volatile Components, in the EMPACT Program: Results from the Salt Lake City Study," *Atmos. Environ.*, 37: 4407-4417.

Obeidi, F.; Eatough, D.J. (2002) Continuous measurement of Semivolatile fine particulate mass in Provo, Utah. *Aerosol Sci. Technol.* 36, 191-203.

Pope, C.A. III (2000). Epidemiology of fine particulate air pollution and human health; Biological mechanisms and who's at risk? *Environ. Health Perspect.* 108(Sup 4): 713-723.

Pope, C.A., Hansen, M.L., Long, R.W., Nielsen, K.R., Eatough, N.L., Wilson, W.E., Eatough, D.J. (2004) "Ambient particulate air pollution, heart rate variability, and blood markers of inflammation in a panel of elderly subjects," *Environ. Health Perspect.*, 112(3): 339-345.

Schwartz, J., Dockery, D.W., Neas, L.M., (1996). Is daily mortality associated specifically with fine particles? *J. Air & Waste Manage. Assoc.* 46: 927-939.

Sioutas, C., Koutrakis, P., Burton, R.M., (1994) "Development and evaluation of a low cutpoint virtual impactor," *Aerosol Sci. Technol.*, 21.

Tang, H., Lewis, E.A., Eatough, D.J., Burton, R.M., Farber, R.J. (1994) "Determination of the particle size distribution and chemical composition of semi-volatile organic compounds in atmospheric fine particles," *Atmos. Environ.*, 28.

Turpin, B.J., Lim, H.J. (2001) "Species contributions to PM_{2.5} mass concentrations: Revisiting common assumptions for estimating organic mass," *Aerosol Sci. Technol.*, 35: 602-610.

Chapter 8. Semi-Continuous Mass Closure of the Major Components of Fine Particulate Matter in Riverside, CA

8.1. Overview

Exposure to fine particulate matter (PM_{2.5}, particles with an aerodynamic diameter less than 2.5 μm) has been implicated as a contributor to adverse human health effects including increases in cardiovascular and pulmonary effects which leads to elevated human mortality and morbidity (Pope, 2000; Schwartz *et al.*, 1996). PM_{2.5} has also been associated with visibility degradation in urban (Watson 2002; Eatough *et al.*, 2003) and pristine environments (Eatough *et al.*, 2005) and contributes to changes in the global radiative balance (Chung and Seinfeld, 2002). Because of the environmental and socioeconomic effects of PM_{2.5} on the human population, PM_{2.5} has become the focus of extensive research over the last decade.

PM_{2.5} in the atmosphere is not composed of a single pollutant but consists of both stable and semi-volatile species. Stable species in the atmosphere include trace metals (including toxic, crustal, and transition metals), elemental carbon (EC), and sulfate. Semi-volatile material (SVM) exists in dynamic equilibrium between the gas and particle phase and includes ammonium nitrate (NH₄NO₃) and low molecular weight organic species. SVM that exists in the atmosphere in the particle phase can be lost from collection media during sampling, making it difficult to measure.

Several integrated samplers have been developed that accurately determine both nonvolatile material (NVM) and both inorganic and organic SVM concentrations, including a modified speciation sampler (Carter *et al.*, 2002), and the particle concentrator-Brigham Young University organic sampling system, PC-BOSS, (Tang *et*

al., 1994; Sioutas *et al.*, 1994; Ding *et al.*, 2002a; Modey *et al.*, 2001; 2002; Ding *et al.*, 2002b; Lewtas *et al.*, 2001; Eatough *et al.*, 2003). Although these samplers can accurately speciate PM_{2.5}, including SVM, 1-h time resolved data are often not possible with integrated samplers, which inhibits the ability to temporally resolve short term changes in pollution levels that often occur in urban environments.

To overcome these problems, the development of real-time or near real-time instruments has been attempted. One of the main advantages of real-time instruments is the ability to temporally resolve short term episodes of PM_{2.5} that occur in urban environments that may be relevant to human health effects. One-hour semi-continuous data has also been shown to increase the performance (i.e., reduce uncertainty) of source apportionment techniques to determine sources, both primary and secondary, of urban PM (Grover *et al.*, In Press). Temporally resolved measurement of all the major components of atmospheric aerosols allows for increased understanding of atmospheric processes, increases the ability to determine the major sources of PM_{2.5} by source apportionment and may aid in an increased understanding of relevant health issues associated with PM_{2.5}. However, quantitative semi-continuous speciation of all the major components of PM_{2.5} in urban environments has eluded researchers.

The application of newly developed semi-continuous aerosol monitors allows for the measurement of all the major species of PM_{2.5} on a 1-h time basis. Temporal resolution of both non-volatile and semi-volatile species is possible. A suite of instruments to measure the major chemical species of PM_{2.5} allows for semi-continuous mass closure. An extensive sampling campaign was conducted in Riverside, CA during July and August, 2005 as part of the Study of Organic Aerosols in Riverside (SOAR,

2005) program applying instruments to measure all the major chemical components, including SVM, of an urban aerosol on a 1-h semi-continuous basis. This chapter reports the first successful attempt to quantitatively measure all the major components of PM_{2.5} on a semi-continuous basis.

8.2. Sampling Methods

8.2.1. Real-time PM_{2.5} Samplers

The various samplers used to monitor PM_{2.5} included samplers to determine mass and chemical components. Each of the samplers used in this study is detailed in the following sections.

R&P TEOM Monitor. Hourly data from an R&P TEOM operating at 50 °C (Patashnick and Rupprecht, 1991) were obtained during the study. Semi-volatile PM is not retained on a conventional TX40 filter at these elevated temperatures, which is required to remove particle-bound water (Mignacca and Stubbs, 1999). With the elevated TEOM filter temperature, this technique measures only non-volatile PM.

R&P FDMS 8500 Unit. The FDMS TEOM (Meyer, *et al.*, 2002) has been validated to measure total mass PM_{2.5} concentrations under standard operating conditions (Grover *et al.*, 2005; Grover *et al.*, accepted) (TX40 filter maintained at 30 °C) and was used for such in this study. Hourly purge cycle data were also obtained, indicating the amount of semi-volatile species evaporated off the TX40 filter.

Fine Particulate Sulfate, and Nitrate. Instrumentation for the measurement of atmospheric inorganic species was outlined in detail in Chapter 2. The instrument used in this study was the TTU soluble ion monitor. Fine particulate nitrate, sulfate and

ammonium concentrations were averaged over 1-h periods for comparison with other semi-continuous data.

Sunset Dual-Oven Carbon Monitor. A Sunset monitor utilizing two consecutive ovens was designed and field tested during this study and has been extensively described in Chapter 7. One-h average concentrations of OC, EC, and SVOC were obtained throughout the study with the dual-oven Sunset monitor.

Anderson Aethalometer. An Anderson Instruments (Model RTAA-900) Aethalometer was used for the determination of aerosol EC as described in Chapter 2. One-h average EC concentrations were obtained and compared with the 1-h averaged FDMS, TEOM, inorganic and Sunset organic data. In addition, one-hour UV absorption data were obtained because this Aethalometer measurement is believed to be a good marker of fresh diesel emissions (Hansen, 2002).

PC-BOSS Sampler. The PC-BOSS was used for sample collection to determine fine particulate mass, sulfate, carbonaceous material (elemental and organic), nitrate, semi-volatile organic material, and semi-volatile nitrate as discussed in Chapter 2. Quartz filter nonvolatile organic carbon and EC, NVOC, and CIG filter semi-volatile carbonaceous material, SVOC, determined with the PC-BOSS were used for comparison with the results obtained with the two Sunset monitors.

Temperature programmed volatilization (Eatough *et al.*, 2003, Ellis and Novakov 1982) was used in the analysis of PC-BOSS collected samples for total carbonaceous material as discussed in Chapter 2. Ion chromatography (IC) was used in the analysis of PC-BOSS filters to determine ambient sulfate and nitrate concentrations as discussed in Chapter 2.

8.2.2. Sample collection

SOAR was an extensive sampling campaign conducted in Riverside, CA, during July - August, 2005. Sampling was performed in the BYU sampling trailer located adjacent to the Fawcett laboratory on the UC Riverside campus. Riverside is located at the eastern end of the Los Angeles basin. $PM_{2.5}$ initiating in Los Angeles is transported across the basin during periods of high photochemical activity. Also stable inversions are frequent during the summertime in the Los Angeles basin, resulting in high secondary particulate organic material and nitrate. Furthermore, several ammonia sources exist near the end of the basin, resulting in high concentrations of fine particulate NH_4NO_3 , much of which is semi-volatile in nature. These conditions result in a good opportunity to study an urban aerosol with high concentrations of both NVM and SVM (Grover *et al.*, 2005).

One-h averaged data were obtained for all of the instruments listed above, excluding the IC instrument and the PC-BOSS. The IC provided 30 min particulate sulfate and nitrate concentrations which were averaged to 1-h for comparison with the other instruments. High PM pollution concentration days were forecasted during the study for the collection of PC-BOSS data. Subsequently, 3-h PC-BOSS data were obtained on 8 days during the sampling campaign.

8.3. Results and Discussion

Figure 8.1 illustrates the data for $PM_{2.5}$ mass and chemical species concentrations obtained over the sampling period. The average concentrations of mass measured by the FDMS and TEOM were 27.7 and 13.8 g/m^3 , respectively (Figure 8.1A). Generally the TEOM monitor tracked the concentrations of mass measured by the FDMS monitor

Figure 8.1. Semi-continuous measurements of PM_{2.5} mass and chemical species. (A) PM_{2.5} mass measurements with the R&P FDMS and TEOM monitors, (B) inorganic sulfate and nitrate measured by the IC based sampler (C) non-volatile organic carbon and semi-volatile organic carbon measured by the dual-oven Sunset monitor, and (D) EC comparison between the dual-oven Sunset monitor and an Anderson Aethalometer.

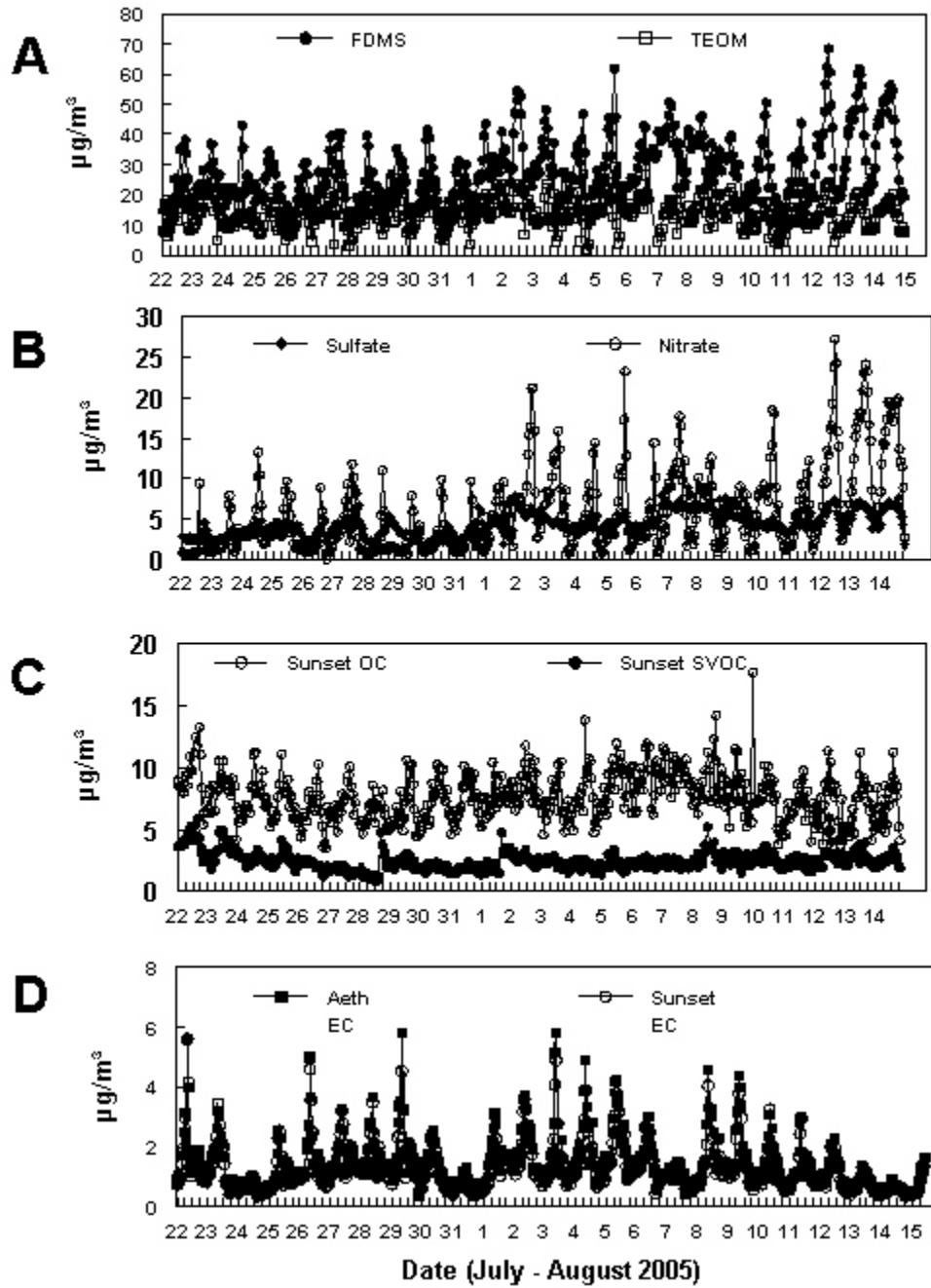

throughout the study with TEOM mass concentrations equal to or less than those measured by the FDMS as would be expected due to the loss of SVM by the heated filter of the TEOM monitor. Therefore, the difference between the FDMS mass concentration and the TEOM measurement is a good estimate of the amount of SVM present in the aerosol (Eatough *et al.*, 2003; Eatough *et al.*, 2001; Grover *et al.*, 2005; Eatough *et al.*, 2000). A typical diurnal pattern was observed in mass concentrations with peak concentrations observed during mid-day time periods. Transport of pollution across the Los Angeles basin dominates the diurnal patterns observed throughout the study. Increases in PM_{2.5} mass concentrations are also effected by local traffic emissions on many weekdays during the study. However, a significant decrease in PM_{2.5} mass is not observed on weekends as would be expected if the aerosol were dominated by local traffic patterns.

Summer time periods of high photochemical activity promote atmospheric reactions resulting in secondary nitrate and sulfate. Gaseous nitric acid can be formed by the reaction of NO₂ with the OH radical during periods of high photochemical activity. SO₂ can also be converted to H₂SO₄ by reaction with the OH radical or by aqueous phase reactions with H₂O₂, O₃, or O₂ (Finlayson-Pitts and Pitts, 1999). Furthermore, HNO₃ and H₂SO₄ react with atmospheric ammonia to form ammonium salts (Finlayson-Pitts and Pitts, 1999). Sulfate and nitrate concentrations measured during the study are shown in Figure 8.1B. Significant ammonia sources exist near the Riverside area, and therefore, it is not unreasonable to assume that inorganic sulfate and nitrate exist mainly as the ammonium salts in the local aerosol (Grover *et al.*, 2005). Average nitrate and sulfate concentrations throughout the study were 5.7 g/m³ and 4.3 g/m³, respectively. The

diurnal variability observed in nitrate concentrations shows peak concentration periods occurring during mid-day when OH radical concentrations would be expected to be highest, resulting in the formation of particulate NH_4NO_3 . Sulfate concentrations were generally low throughout the study and did not exhibit as drastic a diurnal pattern as nitrate. Furthermore, nitrate and sulfate concentrations did not indicate any noticeable weekend - weekday variability.

Organic carbon (OC) concentrations and SVOC measured by the dual-oven Sunset monitor are shown in Figure 8.1C. Average OC and SVOC concentrations were 8.2 g/m^3 and 2.5 g/m^3 , respectively, throughout the study period. OC concentrations exhibited a distinct diurnal pattern throughout the study with peak concentration periods occurring during daytime periods. Furthermore, OC weekend concentrations were similar to those observed on weekdays. SVOC concentrations were generally low throughout the study. Several episodes of SVOC occurred when SVOC concentrations peaked near 5 g/m^3 during mid-day time periods. Otherwise, slightly increased concentrations of SVOC were observed when photochemical activity peaked during daylight periods with lower concentrations observed during nighttime periods. This diurnal pattern in SVOC concentrations is consistent with the formation of SVOC under conditions of photochemical activity that were often observed during daytime hours.

EC concentrations measured by the Sunset and Aethalometer are shown in Figure 8.1D. Good agreement was observed between the two monitoring techniques with linear regression statistics given in Table 8.1. EC concentrations throughout the study are highly correlated with local traffic patterns with peak concentrations observed during

Table 8.1. Linear Regression Statistics for Comparisons Made During the Riverside Study.

X vs Y	n	R ²	Slope ^a	Intercept g/m ³	X Average g/m ³	X-Y Bias g/m ³	g/m ³	%
Sunset EC vs Aeth. EC	562	0.96 0.96	1.11 ± 0.01 1.09 ± 0.01	0 0.0 ± 0.2	1.3	0.1	0.2	12.7
FDMS vs Constructed Mass	541	0.84 0.88	1.01 ± 0.01 0.85 ± 0.01	0 5.4 ± 3.4	27.8	1.0	2.8	9.8
FDMS-TEOM (SVM) vs NH ₄ NO ₃ + SVOM	529	0.79 0.79	0.77 ± 0.01 0.74 ± 0.02	0 0.5 ± 3.3	14.0	-3.0	3.5	28.2

^aSlopes are given for (1) zero intercept and (2) calculated intercept

early morning rush hour time periods. Furthermore, weekend EC concentrations are much lower, especially for Sundays, than weekday concentrations due to decreased local diesel traffic activity.

Mass closure can be obtained with the quantitative measurement of all the major chemical species of PM_{2.5} in an urban aerosol (i.e., the sum of all the respective chemical species should equal the total PM_{2.5} mass). A 1-h average constructed mass was obtained by the summation of sulfate and nitrate (assumed to be present as the ammonium salts), OC and SVOC converted to OM and SVOM by a factor of 1.4 (Turpin and Lim 2001), typical of an aged urban aerosol and consistent with previous studies conducted in the Los Angeles basin, and EC as measured by the Sunset monitor, for each 1-h time period throughout the study. Taking into account propagation of error for the constructed mass, excellent agreement was obtained between constructed mass concentrations and FDMS measured mass concentrations throughout the study, as shown in Figure 8.2. Linear regression analysis data are given in Table 8.1. The propagation of uncertainty in the constructed mass was estimated as:

$$\sigma_{Total} = [\sigma_{(NH_4)_2SO_4}^2 + \sigma_{NH_4NO_3}^2 + \sigma_{EC}^2 + \sigma_{OM}^2 + \sigma_{SVOM}^2]^{1/2} \quad (1)$$

where uncertainties in the respective chemical species measurements were estimated from previous comparisons, resulting in $\sigma_{Total} = 3.8 \text{ g/m}^3$. The observed uncertainty for the study was 2.8 g/m^3 as shown in Table 8.1. Constructed mass concentrations accurately describe measured mass concentrations and display a similar diurnal pattern as observed for measured mass. This good agreement furthermore suggests validation of

Figure 8.2. Constructed mass vs. FDMS measured mass. Constructed mass is the sum of all the major components of the aerosol including; NVOM, SVOM, NH_4NO_3 and ammonium sulfate.

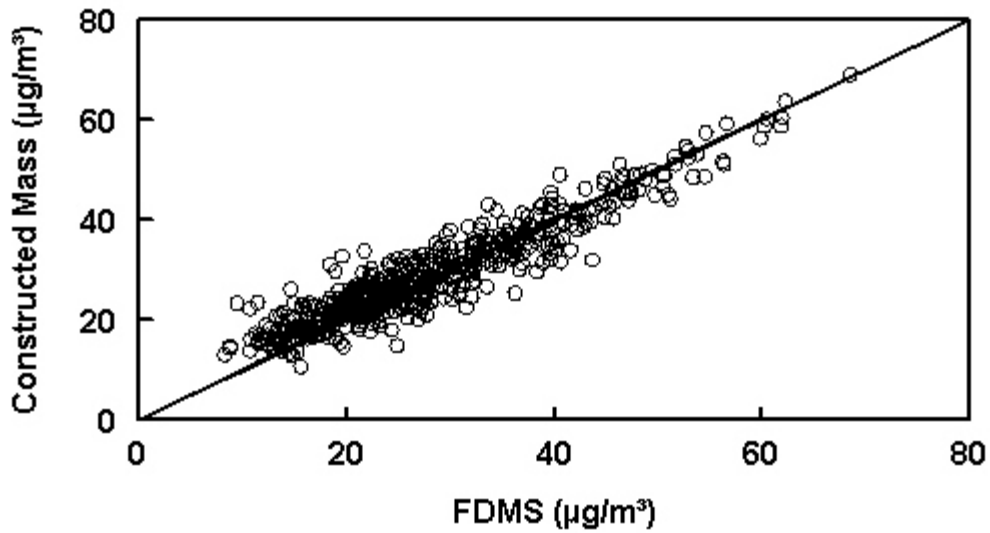
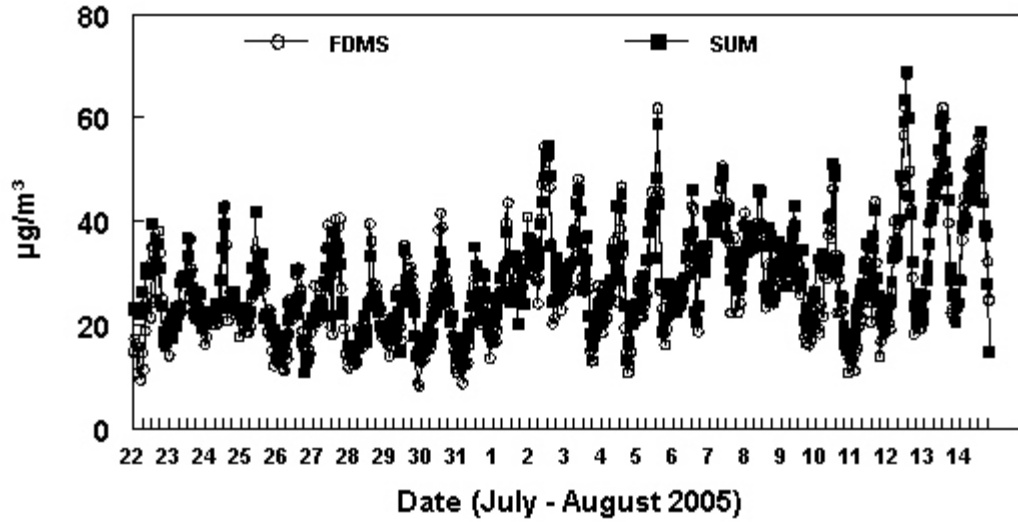

the individual chemical species measurements including SVOC measurements made by the dual-oven Sunset monitor.

A second check on the accuracy of the SVM measurements can be made. An estimate of the amount of SVM present in an aerosol can be obtained by the FDMS concentration minus the TEOM concentration. A comparison was made between 1-h FDMS-TEOM (SVM) and a 1-h sum of the NH_4NO_3 and SVOM throughout the study period. As shown in Figure 8.3, the sum of NH_4NO_3 and SVOM accurately represents the SVM present with linear regression statistics given in Table 8.1. The agreement between the SVM determined by the difference between the FDMS and TEOM monitor concentrations and that obtained by the summation of semi-volatile species affords further confidence that one is accurately determining SVM in the aerosol.

8.4. Conclusions

The semi-continuous measurement of the major components of $\text{PM}_{2.5}$ may be a benefit to State and local regulatory agencies, allowing the temporal resolution of $\text{PM}_{2.5}$ species in urban atmospheres. Short-term temporal resolution of the major species of $\text{PM}_{2.5}$ will allow for better forecasting of $\text{PM}_{2.5}$ episodes and may lead to increased understanding of related health effects. Furthermore, mass closure can be obtained on a 1-h time basis. A suite of instruments to measure the major components of $\text{PM}_{2.5}$ semi-continuously has been suggested. Inorganic particulate sulfate and nitrate can be measured by an IC based aerosol sampling instrument. A dual-oven Sunset carbon monitor can be employed to measure NVOM, EC and SVOM with a 1-h time resolution. Constructed mass concentrations showed good agreement with the FDMS measured mass with an observed uncertainty less than the propagation of error estimated uncertainty.

Figure 8.3. Comparison of SVM determined by the FDMS-TEOM with the sum of SVOM, measured by the dual-oven Sunset monitor, and NH_4NO_3 , measured by the IC sampler.

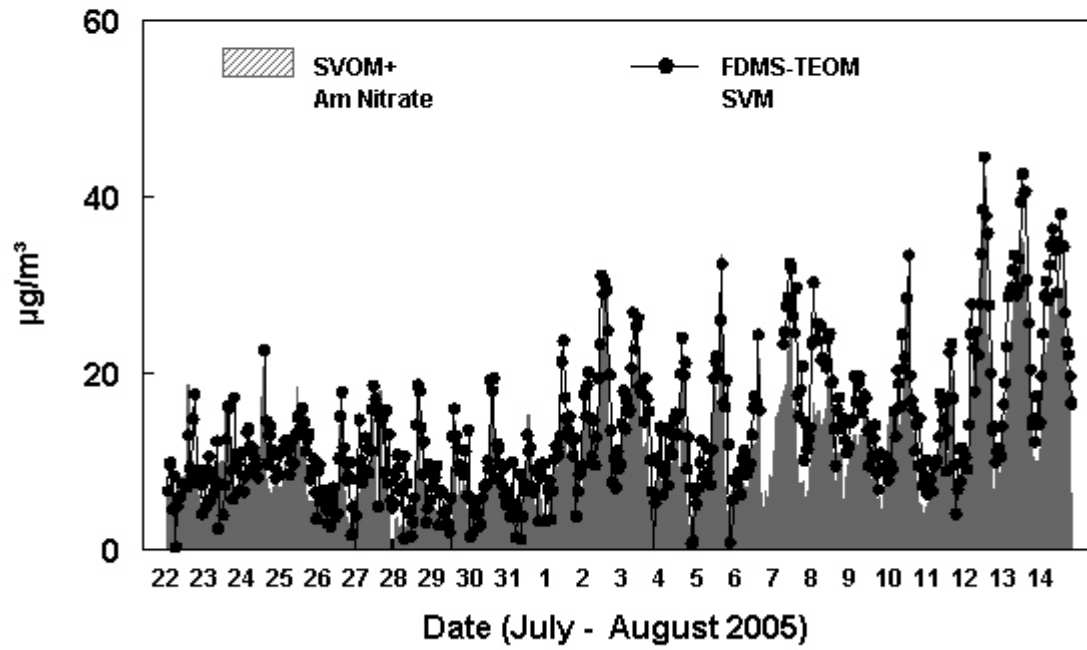

8.5. References

- Al-Horr, R., Samantha, G., and Dasgupta, P.K. (2003). A Continuous Analyzer for Soluble Anionic Constituents and Ammonium in Atmospheric Particulate Matter. *Aerosol. Sci. Technol.* 37: 5711-5720.
- Boring, C.B., Al-Horr, R., Genfa, Z., Dasgupta, P.K., Martin M.W., and Smith, W.F. (2002). Field Measurements of Acid Gases and Soluble Anions in Atmospheric Particulate Matter using a Parallel Plate Wet Denuder and Alternating Filter-Based Automated Analysis System. *Anal. Chem.* 74: 1256-1268.
- Carter, C., Long, R. W., Eatough, N. L., and Eatough D. J., (2002). Comparison of Speciation Sampler and PC-BOSS PM_{2.5} Organic Material Results Obtained on the Wasatch Front During the Winter of 2001-2002. *Pro. AWMA 2002 Annual Conf.* 767.
- Chung, S. H., and Seinfeld, J. H., (2002). Global Distribution and Climate Forcing of Carbonaceous Aerosols. *J. Geophysical Research.* 107: 4407.
- Dasgupta, P.K., Poruthoor, S.K. (2002). *Comprehensive Analytical Chemistry, 37th ed.*, J. Pawliszyn, ed., Elsevier Science B.V., Amsterdam, 2002; pp 161-276.
- Ding, Y., Pang, Y., Eatough, D.J., Eatough, N.L., and Tanner, R.L. (2002). High-Volume Diffusion Denuder Samplers for the Routine Monitoring of Fine Particulate Matter: I. Design and Optimization of the PC-BOSS. *Aerosol Sci. Technol.* 36: 369-382.
- Ding, Y., Pang, Y., Eatough, D.J., Eatough, N.L., and Tanner, R.L. (2002). High-Volume Diffusion Denuder Samplers for the Routine Monitoring of Fine Particulate Matter: II. Field Evaluation of the PC-BOSS. *Aerosol Sci. Technol.* 36: 383-396.
- Eatough, D. J., Eatough, D. A., Lewis, L., and Lewis, E. A., (1996) Fine Particulate Chemical Composition and Light Extinction at Canyonlands National Park using Organic Particulate Material Concentrations Obtained with a Multisystem, Multichannel Diffusion Denuder Sampler. *J. Geophysical Research.* 101: 19514-19531.
- Eatough, D.J., Eatough, N.L., Obeidi, F., Pang, Y., Modey, W., Long, R., "Continuous determination of PM_{2.5} mass, including semi-volatile species," *Aerosol Sci. Technol.*, 34: 1-8, (2000).
- Eatough, D.J., Eatough, N.L., Obeidi, F., Pang, Y., Modey, W., and Long, R. (2001) Continuous determination of PM_{2.5} mass, Including Semi-Volatile Species. *Aerosol Sci. Technol.* 34, 1-8.
- Eatough, D.J., Long, R.W., Modey, W.K., Eatough, N.L. (2003). Semi-Volatile Secondary Organic Aerosol in Urban Atmospheres: Meeting a Measurement Challenge. *Atmos. Environ.* 37: 1277-1292.

Ellis, E.C. and Novakov, T., "Application of thermal analysis to the characterization of organic aerosol particles," *Sci. Total Environment*, 23, (1982).

Finlayson-Pitts B.J, J. N. Pitts, (1999) *Chemistry of the Upper and Lower Atmosphere* Academic Press, San Diego, CA.

Grover, B. D, Carter, C. B. Kleinman, M. A., Richards, J. S., Eatough, N. L. and Eatough, D. J. Monitoring and Source Apportionment of Fine Particulate Matter at Lindon, Utah. *Aerosol Sci. Technol.* In Press.

Grover, B .D., Kleinman, M. A., Eatough, N. L., Eatough, D. J., Hopke, P. K., Long, R. W., Wilson, W. E., Meyer, M. B., Ambs, J. L. (2005) Measurement of Total PM_{2.5} Mass (Nonvolatile plus Semi-Volatile) with the FDMS TEOM Monitor. *J. Geophysical Research*, 110, D07S03.

Grover, B.D., Eatough, N. L., Eatough, D. J., Chow, J. C., Watson, J. G., Ambs, J. L., Meyer, M. B., Hopke, P.K., Al-Horr, R., Later, D. W., Wilson, W. E., Measurement of Both Nonvolatile and Semi-Volatile Fractions of Fine Particulate Matter in Fresno, CA. *Aerosol Sci. Technol.* Accepted for Publication.

Hansen, A.D.A (2002). *The Aethalometer Operating Manual*, http://www.mageesci.com/Aethalometer_book_2002.06.5.pdf, accessed September 16, 2002.

Lewtas, J., Booth, D., Pang, Y., Reimer, S, Eatough, D.J., and Gundel, L. (2001). Comparison of sampling methods for semi-volatile organic carbon (SVOC) associated with PM_{2.5}. *Aerosol Sci. Technol.* 34: 9-22.

Long, R.W., Smith, R., Smith, S., Eatough, N.L., Mangelson and Eatough, D.J. (2002) Sources of Fine Particulate Material along the Wasatch Front, *Energy and Fuels*. 16: 282-293.

Long, R.W., Eatough, N.L., Mangelson, N.F., Thompson, W., Fiet, K., Smith, S., Smith, R., Eatough, D.J., Pope, C.A., Wilson, W.E. (2003) "The Measurement of PM_{2.5}, Including Semi-Volatile Components, in the EMPACT Program: Results from the Salt Lake City Study," *Atmospheric Environment*, 37: 4407-4417.

Meyer, M.B., Patashnick, H., and Ambs, J.L., Ongoing development of a continuous reference standard particulate matter mass monitor for ambient air, paper presented at the Symposium on Air Quality Measurement Methods and Technology, San Francisco, CA, November, 2002.

Mignacca, D., Stubbs, K. (1999) Effects of Equilibration temperature on PM₁₀ Concentrations from the TEOM Method in the Lower Fraser Valley. *J. of Air & Waste Manage. Assoc.* 49: 1250-1254.

Modey, W. K., Pang, Y., Eatough, N. L., and Eatough, D. J., (2001) Fine Particulate (PM_{2.5}) Composition in Atlanta, USA: Assessment of the Particle Concentrator Brigham Young University Organic Sampling System, PC-BOSS, During the EPA Supersite Study, *Atmos. Environ.* 35, 6493-6502.

Obeidi, F.; Eatough, D.J. (2002) Continuous measurement of Semivolatile fine particulate mass in Provo, Utah. *Aerosol Sci. Technol.* 36, 191-203.

Patashnick, H., Rupprecht, E. G. (1991) Continuous PM₁₀ measurements using the tapered element oscillating microbalance. *J. of Air & Waste Manage. Assoc.* 41: 1079-1083.

Pope, C.A. III (2000). Epidemiology of fine particulate air pollution and human health; Biological mechanisms and who's at risk? *Environ. Health Perspect.* 108(Sup 4): 713-723.

Pope, C. A. III, Hansen, M. L., Long, R. W., Nielson, K. R., Eatough, N. L., Wilson, W. E., Eatough, D. J. (2004). Particulate Air Pollution, HRV, and Inflammation. *Environ. Health Perspect.* 112: 339-345.

Schwartz, J., Dockery, D.W., Neas, L.M., (1996). Is daily mortality associated specifically with fine particles? *J. Air & Waste Manage. Assoc.* 46: 927-939.

Sioutas, C., Koutrakis, P., and Burton, R.M. (1994). Development and Evaluation of a Low Cutpoint Virtual Impactor. *Aerosol Sci. Technol.* 21: 223-235.

Study of Organic Aerosols at Riverside, SOAR, (2005).
<http://cires.colorado.edu/jimenez-group/Field/Riverside05>

Tang, H., Lewis, E. A., Eatough, D. J., Burton, R. M., and Farber, R. J. (1994). Determination of the particle size distribution and chemical composition of semi-volatile organic compounds in atmospheric fine particles. *Atmos. Environ.* 28: 939-947.

Turpin, B.J., and Lim, H.J. (2001). Species Contributions to PM_{2.5} Mass Concentrations: Revisiting Common Assumptions for Estimating Organic Mass. *Aerosol Sci. Technol.* 35: 602-610.

Watson, J. G., Chow, J. C., Bowen, J. L., Lowenthal, D. H., Hering, S., Ouchida, P., and Oslund, W. (2000). Air quality measurements from the Fresno Supersite. *J. Air & Waste Manage. Assoc.* 50 (8): 1321-1334.

Chapter 9. Controlled Exposure Chamber Design for PM_{2.5} Exposure Studies

9.1. Overview

Exposure to airborne particulate matter (PM) has been associated with human health endpoints including increases in mortality and morbidity due to respiratory and cardiovascular disease (Pope *et al.*, 2000; Schwartz *et al.*, 1996). A variety of sources contribute to ambient PM in urban atmospheres, including fossil fuel combustion from both gasoline and diesel engines, stationary fossil fuel combustion sources from industrial processes, and wood burning home fireplace combustion. Recognition of fine and coarse particles as different classes of PM pollutants has aided in the understanding and control of PM in urban atmospheres. Fine particulate matter in urban atmospheres is not a single pollutant but instead is a composite of several chemical species including sulfate, nitrate, ammonium ions, and hydrogen ion, trace elements (including toxic and transition metals), organic material, elemental carbon, and crustal components.

Under the Integrated Air Cancer Project (IACP) of the EPA (IACP, 1988), toxicological links between genotoxic compounds in urban PM and human health have been elucidated (Hannigan *et al.*, 1994; Lewtas *et al.*, 1991; MacGregor *et al.*, 1994; Lewis *et al.*, 1991). These studies indicate that concentrations of both gas- and particulate-phase mutagens in urban atmospheres are highly associated with products of photochemistry between NO_x and automotive and wood-smoke organic emissions (Lewis *et al.*, 1991; Lewis *et al.*, 1988; Walsh *et al.*, 1993). Evidence suggests that these photochemically formed semi-volatile species may also contribute to the exacerbation of respiratory and cardiovascular disease (Pope *et al.*, 2004). Therefore, instruments have been developed to correctly monitor PM including semi-volatile species (Eatough *et al.*,

1999; Eatough *et al.*, 2001). Although a link between genotoxic compounds in urban atmospheres and adverse health effects has been established, a clear understanding of health effects related to specific particulate sources and composition is lacking.

Various techniques have been used to link cardiac autonomic function with exposure to PM for both environmental tobacco smoke and ambient PM exposure epidemiological studies. These studies have shown that changes in heart rate variability (HVR) (Liao *et al.*, 1999; Gold *et al.*, 2000; Pope *et al.*, 1999a; Pope *et al.*, 2004) and heart rate (HR) (Pope *et al.*, 1999b) measured using electrocardiography (ECG) as well as markers of blood inflammation (Pope *et al.*, 2004) provide specific, quantitative indications of cardiac autonomic function (ESC 1996).

Under a recently performed EPA Science to Achieve Results (STAR) study, health effects data including changes in HR, HRV, and markers of blood inflammation were obtained for elderly individuals near three ambient monitoring sites along the Wasatch Front for two winters and one summer (Pope *et al.*, 2004). These studies include the detailed chemical composition and determination of sources of ambient PM_{2.5} at a central monitoring site (Long *et al.*, 2003). Potential weak links in these and similar ambient health effects studies are that no personal exposure data for each participant in the studies are obtainable because experimental techniques do not allow for the facile determination of the wide variety of PM_{2.5} components. Therefore, validation of implied health effects by controlled exposure studies would be valuable.

Facilities at Brigham Young University, including a collapsible 30 m³ Teflon bag connected to a controlled exposure study chamber via a dedicated recirculating system, have been developed for controlled human exposure studies to determine health effects

related to specific sources and composition of PM_{2.5} pollutants. This chapter discusses the set-up and design of this controlled exposure chamber as well as the characterization of wood smoke exposure in the chamber facility.

9.2. Experimental Methods and Procedures

9.2.1. Sampling Methods

R&P TEOM Monitor. One-min nonvolatile PM_{2.5} mass concentrations were determined using an R&P TEOM monitor operating under normal conditions (Patashnick and Rupprecht, 1991). Semi-volatile PM evaporated at the standard operating temperature of the instrument, 50 °C, which is required to remove particle bound water (Mignacca and Stubbs, 1999). This technique measures only PM which is nonvolatile at the TEOM filter temperature.

BOSS Sampler. The Brigham Young University organic sampling system (BOSS) was used to determine fine particulate mass, trace elements, sulfate, elemental carbon, organic carbon, nitrate, semi-volatile organic material and semi-volatile nitrate. The configuration and operation of the BOSS sampler has been described in Chapter 2. Samples for the chemical characterization of PM following a BOSS diffusion denuder were collected in a filter pack containing pre-fired 47 mm quartz filter (Pallflex) followed by 47 mm charcoal-impregnated glass fiber filter (CIG, Schliecher and Schuell) to determine fine particulate sulfate, nitrate, organic material and elemental carbon including any semi-volatile nitrate or organic material. A parallel filter pack containing a 47mm Teflon (Whatman) filter followed by a 47 mm Nylon (Gelman, Nylasorb) filter was used to determine PM filter-retained (non-volatile) mass, sulfate and nitrate, plus any

nitrate lost from the particles during sample collection. Thirty-minute samples were collected at different times in the Teflon bag and controlled exposure chamber room.

RAMS. The real-time total ambient mass sampler (RAMS), based on diffusion denuder, Nafion dryer and TEOM monitor technology, was used for the real-time determination of total PM_{2.5} mass, including semi-volatile species (Eatough *et al.*, 1999; Eatough *et al.*, 2001). The configuration and operation of the RAMS as used in the controlled exposure chamber studies was described in Chapter 2 (Eatough *et al.*, 1999; Eatough *et al.*, 2001; Long *et al.*, 2000; Long *et al.*, 2001). One-min averaged RAMS data were collected from the Teflon bag during the controlled exposure chamber periods for the determination of total PM mass, including SVM.

TSI SMPS/CPC Monitor. A TSI monitor (Model 3020), see Chapter 2, was used for the determination of detailed particle size distribution and to determine total fine particle number. Total particle number was dominated by ultra-fine particles (<100 nm). This instrument is a real-time monitor; therefore, data were averaged over 5-min periods in the Teflon bag throughout the study.

Gas-Phase Monitors. Real-time concentrations of CO were determined using a API model 300 carbon monoxide monitor. Real-time concentrations of NO, NO₂, and NO_x were determined using a Thermo Environmental Instruments Model 42 NO_x analyzer.

9.2.2. Analytical Methods

Mettler UMT2 Microbalance. A Mettler UMT2 microbalance was used for the determination of collected fine particle mass on a 47 mm Teflon (Whatman) filter sampled from the BOSS sampler.

TPV Analysis. Temperature programmed volatilization (Tang *et al.*, 1994; Ellis and Novakov, 1982) was used in the analysis of collected samples for total carbonaceous material as described in Chapter 2.

Dionex Ion Chromatograph. A Dionex Model 500 ion chromatograph with a separator column, anion fiber suppressor, and conductivity detector was used for the analysis of collected samples for nitrate and sulfate as described in Chapter 2.

9.3. Chamber Design

9.3.1. Exposure Facility

Atmospheric research facilities at Brigham Young University include a 30 m³ Teflon chamber which has been previously described (Benner *et al.*, 1999; Eatough *et al.*, 1989). The Teflon chamber is equipped with a UV and black lamp system provided by 200 F40BL General Electric black lights (365 nm) and 12 FS40UVB sunlamps (Commercial Lighting, Salt Lake City, UT) for the simulation of ambient sunlight. The previously mentioned instruments were connected to the Teflon bag via a Teflon sampling manifold located at the bottom of the bag for the complete determination of chemical composition and concentration of the combustion generated aerosol provided to the Teflon bag. Adjacent to the Teflon bag is a 15 m³ controlled exposure chamber similar to the facility previously described (Lewis *et al.*, 1989). The controlled exposure chamber is connected to the Teflon bag via a dedicated recirculation system. A Teflon coated manifold is connected to the controlled exposure room via a ½ inch stainless steel tube. Complete chemical composition and characterization of the controlled exposure chamber was obtained by sampling through the Teflon coated manifold using the

previously mentioned instruments. A complete schematic of the controlled exposure chamber design is given in Figure 9.1.

9.3.2. Aerosol Generation

A combustion generated aerosol was sampled from the flue line of a certified wood burning stove (Regency) typical of those found in homes throughout the United States. Firemaster natural pine wood (SBC Firemaster Langley, B.C., Canada) was used for the generation of wood smoke. After complete ignition, the wood was allowed to burn for at least 15-min at a low burn rate (i.e. wood stove damper completely closed) before sampling. Because the aerosol may contain CO concentrations substantially above the national ambient air quality standards, the concentrations of CO were reduced by passage of the aerosol through a heated (100 °C) metal catalyst honeycomb support designed to have greater than 95% efficiency for the conversion of CO to CO₂ with essentially no removal of fine particles, gas phase organic compounds, NO or NO₂. NO, NO₂ and gas phase organic compound concentrations were maintained in the test aerosol to facilitate the photochemical aging of the combustion generated emissions. The combustion generated aerosol was moved through ½ inch stainless steel tubing via an in-line fan (Fantech model FR100) into the Teflon bag.

9.3.3. Test Aerosols

Both fresh and aged wood smoke were used as combustion generated aerosols in the controlled exposure chamber studies. Fresh wood smoke was generated by direct sampling of combustion wood smoke from the certified wood burning stove. Aged wood smoke was generated by sampling fresh wood smoke from the flue line of the wood

Figure 9.1. Schematic of controlled exposure chamber facility at Brigham Young University.

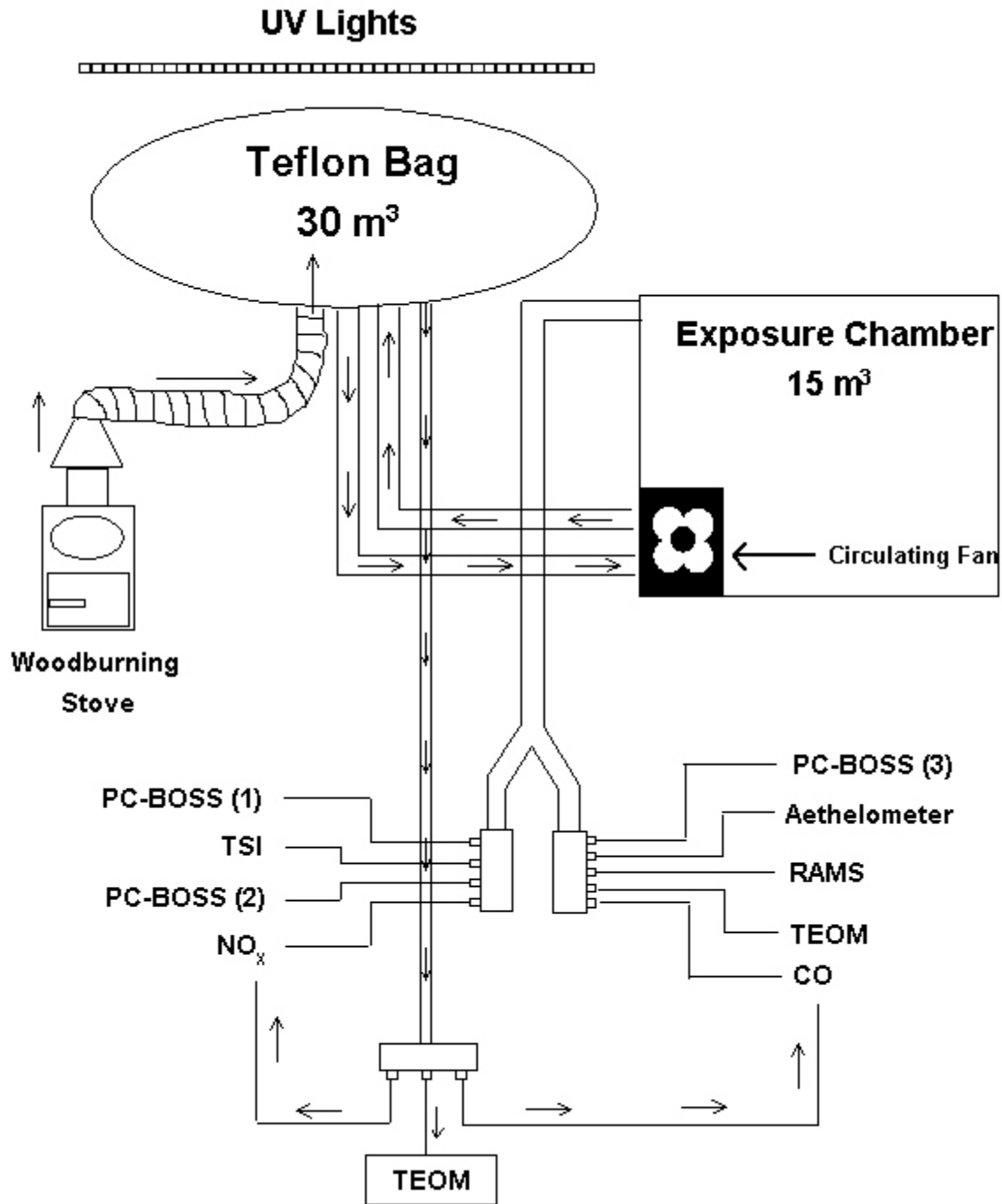

burning stove with subsequent exposure of the PM to UV/black light radiation in the Teflon bag for the simulation of ambient sunlight.

9.4. Results and Discussion

Several experiments were performed with the combustion generated wood smoke aerosol to determine the chemical composition of wood smoke in both the Teflon bag and the controlled chamber exposure facility. The Teflon bag was cleaned prior to each experiment by exposure to O₃ with the UV/black light system on and subsequent flushing of the bag with “clean” lab air until PM_{2.5} concentrations were negligible in the Teflon bag.

A combustion generated wood smoke aerosol was introduced into the Teflon bag via the described system to a concentration of approximately three to four times the concentration desired in the controlled exposure chamber room and allowed to equilibrate. One-min averaged RAMS and TEOM data were obtained for approximately four hours of UV/black light exposure. TEOM data were also obtained during a 4-h period with no UV/black light exposure. The normalized data can be seen in Figure 9.2. Wood smoke concentrations with no UV/black light exposure decrease over time due to the deposition of particles on the Teflon bag wall. When wood smoke emissions are exposed to simulated ambient light, the concentration of PM_{2.5} increased. This increase in concentration, due to exposure to the UV/black light generated radiation, is due to photochemical processes that aid in the formation of particles. The concentration of PM_{2.5} measured by the RAMS is larger than the concentration of PM_{2.5} measured by the TEOM. The difference in the RAMS and TEOM measurement has been shown to be a good estimate, due to the loss of SVM from the heated filter of the TEOM monitor, of the

concentration of SVM present in the aerosol, as shown in Figure 9.2 (Eatough *et. al.*, 1999; Eatough *et. al.*, 2001; Long *et. al.*, 2000; Long *et. al.*, 2001).

9.4.1. Chemical Composition of a Photochemically Aged Aerosol in the Teflon Bag

A combustion generated wood smoke aerosol was introduced into the Teflon bag. When the $PM_{2.5}$ concentration reached a maximum, the UV/black light system was turned on. One-min RAMS and TEOM data were obtained throughout the photochemical period. Two 30-min BOSS samples were collected during the photochemical period for the detailed determination of particle composition (Figure 9.3). As expected, $PM_{2.5}$ concentrations measured by the RAMS were greater than $PM_{2.5}$ concentrations measured by the TEOM because the RAMS measures total $PM_{2.5}$ concentrations, including SVM. It was assumed that fine particulate organic material (OM) was 62% carbon, typical of an aged urban aerosol (Turpin and Lim, 2001). Chemical composition data determined by analysis of the BOSS filters indicated that the majority of the combustion generated PM (~66%) was non-volatile organic material (NVOM). Semi-volatile organic material (SVOM) concentrations averaged 15 % of the PM composition. The BOSS SVOM and semi-volatile nitrate were directly determined from the CIG and nylon filters of the BOSS, respectively. The mass difference between the RAMS and the TEOM were larger than the BOSS measured SVM. This is due to loss of additional SVM from the heated TEOM filter at 50 °C. It was assumed that all nitrate mass was lost from the TEOM filter. The TEOM SVOM was determined by the total RAMS average mass over the time interval minus the total TEOM average mass over the time interval minus the nitrate concentrations (both non-volatile nitrate and semi-volatile nitrate). The water mass was

Figure 9.2. Normalized RAMS, TEOM and normal decay data for wood smoke in the Teflon bag.

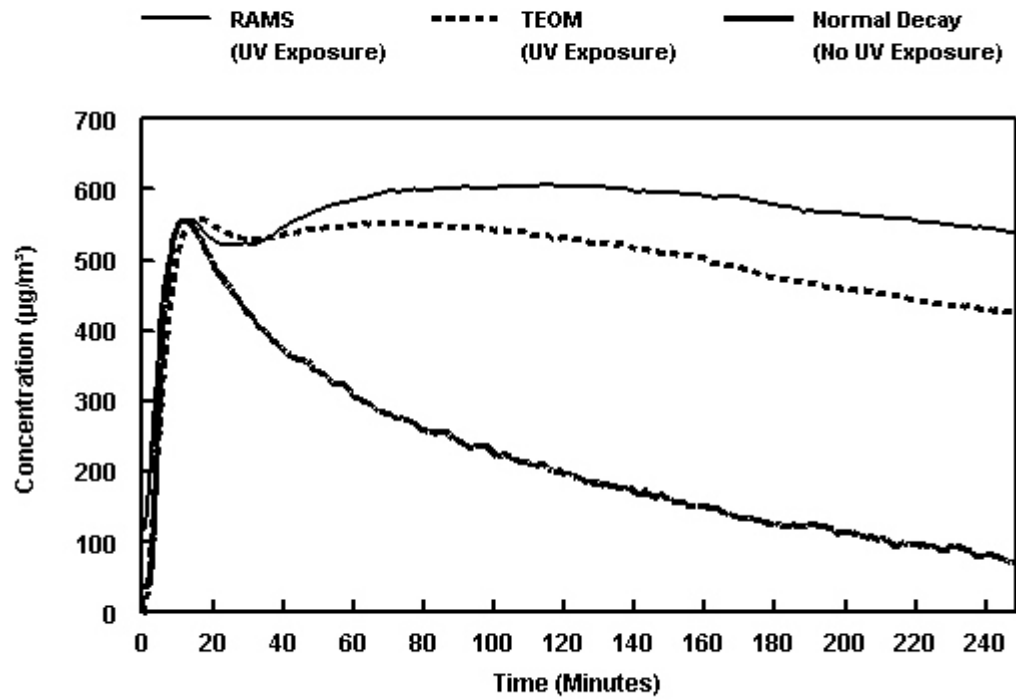
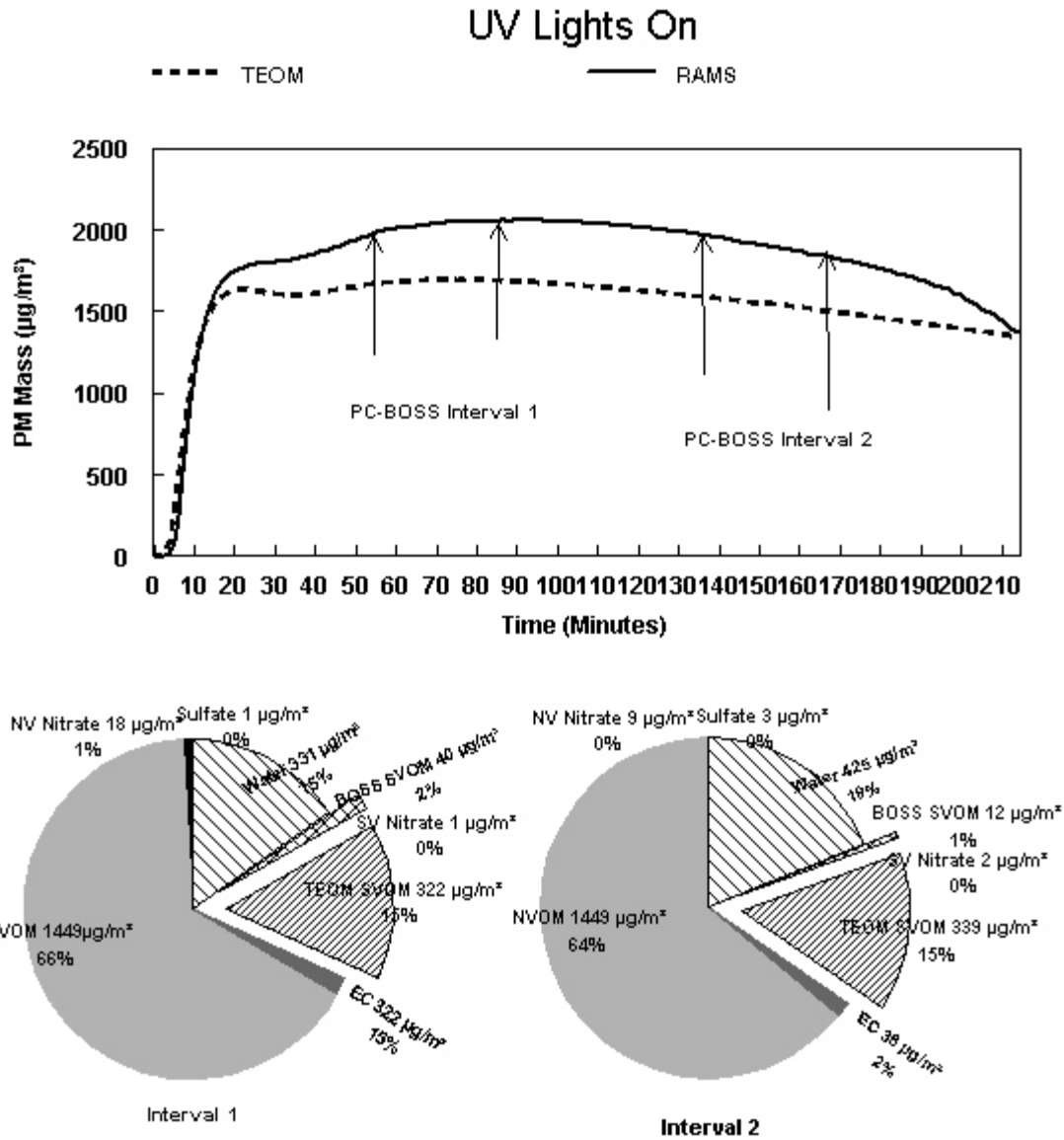

Figure 9.3. Chemical composition of a wood smoke aerosol in the Teflon bag including RAMS, TEOM and BOSS data. Pie graph area is relative to PM concentration. Concentrations are given in $\mu\text{g}/\text{m}^3$.



estimated as the total mass measured on the BOSS Teflon filter minus the constructed non-water filter retained mass (non-volatile nitrate + sulfate + NVOM + EC). Nitrate (both non-volatile and semi-volatile), sulfate, and elemental carbon (EC) were all small fractions of the total PM composition.

A second exposure study was performed on UV/black light exposed wood smoke. RAMS and TEOM monitors were employed to measure total $PM_{2.5}$ and non-volatile $PM_{2.5}$ concentrations, respectively. One 30-min BOSS sample was obtained during the exposure period to determine the composition of PM. A TSI CPC monitor was used to determine the particle size distribution of the aerosol. The resulting data are given in Figure 9.4. The PM chemical composition of aerosol as determined by the BOSS samples is different than the previously mentioned aerosol. The concentration of EC was much larger in this experiment compared to that previously described. This difference is most likely due to the inability to precisely control the burn parameters in the wood burning stove when generating a wood smoke aerosol. RAMS and TEOM data followed the trends previously mentioned. NVOM dominated the composition of the PM as previously seen. Data obtained from the TSI CPC monitor indicate an increase in the median particle diameter and a decrease in the particle concentration (number of particles/cm³) over the sampling time period. This is most likely the result of coagulation of combustion generated ultra-fine particles into larger particles over time, or the possible growth of particles as more secondary species are formed under photochemical conditions.

Figure 9.4. Second exposure study of the chemical composition of wood smoke in the Teflon bag. Total PM concentrations are given in $\mu\text{g}/\text{m}^3$.

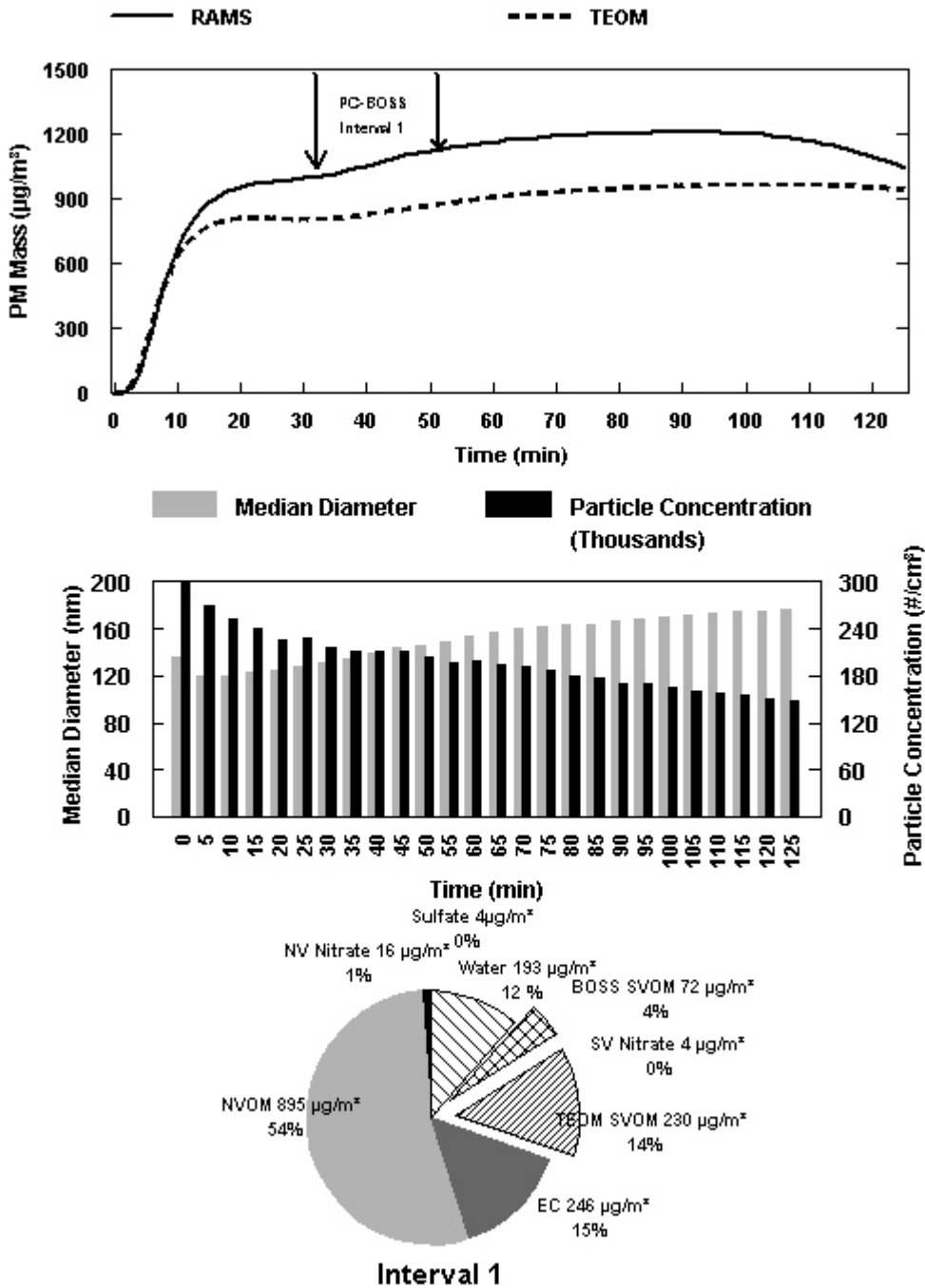

9.4.2. Chemical Composition of the Aerosol in the Controlled Exposure Chamber Room

Fresh wood smoke without UV/black light exposure was introduced into the Teflon bag and allowed to equilibrate. The generated aerosol was subsequently moved into the controlled exposure chamber room and a 30-min BOSS sample was obtained to determine the chemical composition of the aerosol (Figure 9.5). NVOM dominated the PM composition. Furthermore, particle bound water concentrations were reduced with the transport of the aerosol into the controlled exposure chamber room as illustrated in Figure 9.5.

Characterization of a photochemically aged wood smoke aerosol in the controlled exposure chamber room was also obtained. Wood smoke was sampled into the Teflon bag and exposed to UV/black light radiation. One-min averaged RAMS and TEOM monitor data were obtained in the Teflon bag. A 30-min BOSS sample was also obtained in the Teflon bag. The photochemically aged wood smoke was subsequently moved into the controlled exposure chamber room via the dedicated recirculation system. A TEOM monitor was used to determine non-volatile $PM_{2.5}$ concentrations in the room and a 30-min BOSS sample was also obtained to determine the chemical composition of the aerosol in the room (Figure 9.6). NVOM dominated the chemical composition of the PM in both the Teflon bag and the exposure room. When the aerosol was moved from the Teflon bag to the exposure chamber room, the amount of particle bound water decreased. Otherwise, the chemical compositions of the aerosol in the Teflon bag and the exposure chamber room were similar.

Figure 9.5. BOSS obtained data of the chemical composition of fresh wood smoke in the controlled exposure room. Total PM concentrations are given in $\mu\text{g}/\text{m}^3$.

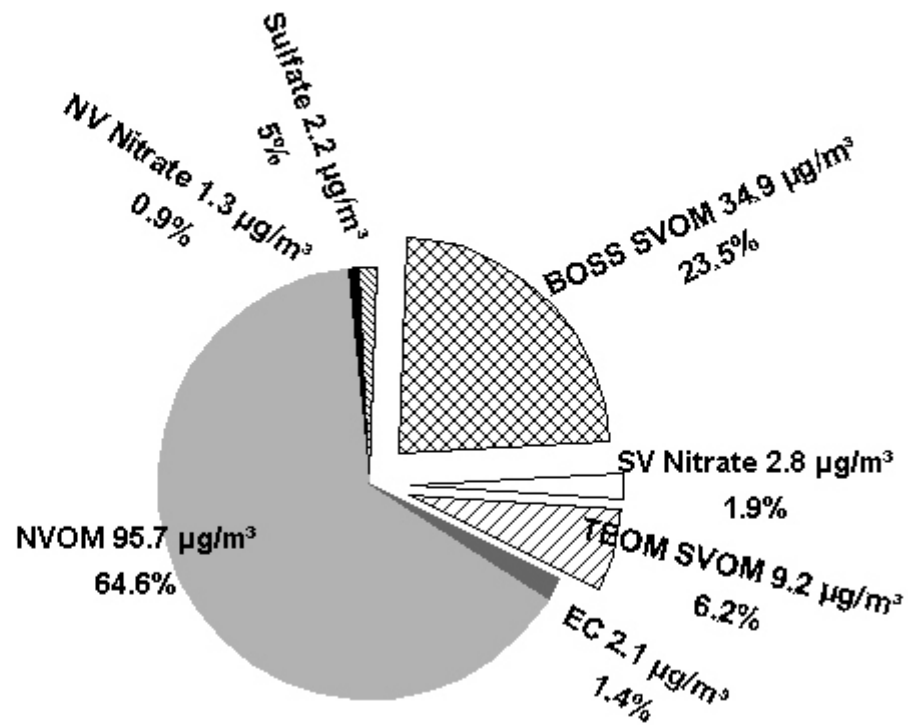
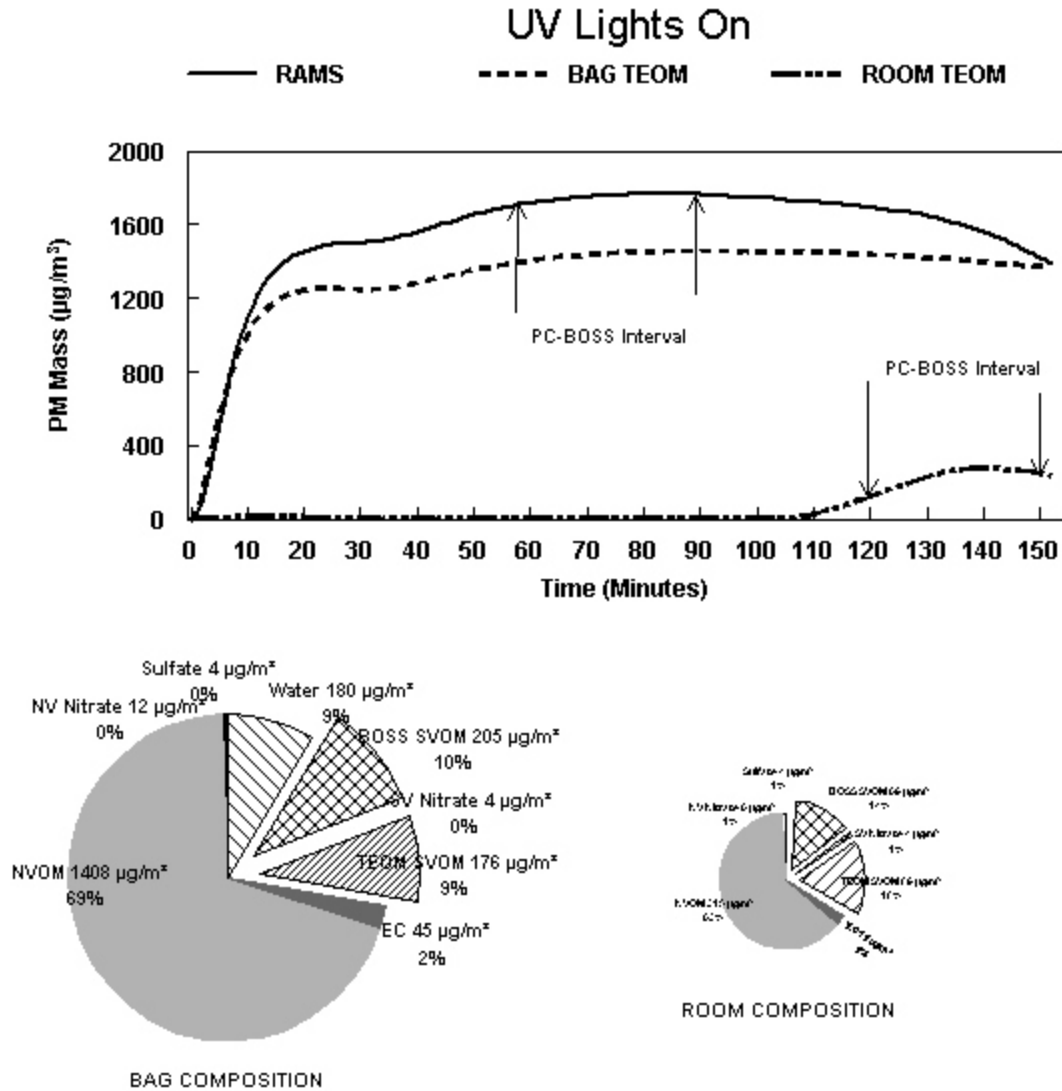

Figure 9.6. Chemical composition of a wood smoke aerosol in the Teflon bag and subsequent composition when moved into the controlled exposure room. Pie graph area is relative to PM concentration.



9.5. Summary

The Teflon bag and controlled human exposure chamber can be rapidly charged to the desired concentrations by sampling from the flue line of a certified wood burning stove. Combustion related PM can be moved from the Teflon bag into the controlled exposure room until the desired concentration is obtained. One-min averaged real-time TEOM and RAMS data can be used to track the concentrations of PM in both the Teflon bag and controlled exposure room. Half-hour BOSS samples allowed for the determine of detailed particle composition of the aerosol in the Teflon bag and controlled exposure room.

9.6. References

- Benner, L.C., Bayona, J.M., Caka, F.M., Tang, H., Lewis, L., Crawford, J., Lamb, J.D., Lee, M.L., Lewis, E.A., Hansen, L.D., and Eatough, D.J., (1989). Chemical Composition of Environmental Tobacco Smoke. 2. Particulate-Phase Compounds. *Environ. Sci. Technol.* 23: 688-699.
- Eatough, D.J., Benner, C.L., Bayona, J.M., Richards, G., Lamb, J.D., Lee, M.L., Lewis, E.A., and Hansen, L.D., (1989). Chemical Composition of Environmental Tobacco Smoke. 1. Gas-Phase Acids and Bases. *Environ. Sci. Technol.* 23: 679-687.
- Eatough, D.J., Obeidi, F., Pang, Y., Ding, Y., Eatough, N.L., and Wilson, W.E., (1999). Integrated and real-time diffusion denuder samplers for PM_{2.5} based on BOSS, PC and TEOM technology. *Atmos. Environ.* 33: 2835-2844.
- Eatough, D.J., Eatough, N.L., Obeidi, F., Pang, Y., Modey, W., and Long, R.W. (2001). Continuous determination of PM_{2.5} mass, Including Semi-Volatile Species. *Aerosol Sci. Technol.* 34: 1-8.
- Gold, D.R., Litonjua, A., Schwartz, J., Lovett, E., Larson, A., Nearing, B., Allen, G., Verrier, M., Cherry, R., Verrier, R., (2000). Ambient Pollution and Heart Rate Variability. *Circulation* 101: 1267-1273.
- Hannigan, M.P., Cass, G.R., Lafleur, A.L., Longwell, J.P., and Thilly, W.G. (1994). Bacterial mutagenicity of urban organic aerosol sources in comparison to atmospheric samples. *Environ. Sci. Technol.* 28: 2014-2024.

IACP, (1988). Integrated Air Cancer Project Study, Session Papers in Measurement of Toxic and Related Air Pollutants, U.S. EPA/APCA, pp. 799-895.

Lewis, C.W., Baumgardner, R.E., Stevens, R.K., Claxton, L.D., and Lewtas, J., (1988). Contribution of Woodsmoke And Motor Vehicle Emissions to Ambient Aerosol Mutagenicity. *Environ. Sci. Technol.* 22: 968-971.

Lewtas, J., (1991). Emerging methodologies for assessment of complex mixtures. Application of bioassays in the Integrated Air Cancer Project. *Advances in Modern Environ. Toxicol.* 19: 137-146.

Lewtas, J., Booth, D., Pang, Y., Reimer, S., Eatough, D.J., and Gundel, L., (2001). Comparison of sampling methods for semi-volatile organic carbon (SVOC) associated with PM_{2.5}. *Aerosol Sci. Technol.* 34: 9-22.

Liao, D., Creason, J., Shy, C., Williams, R., Watts, R., Zweidinger R., (1999). Daily Variation of Particulate Air Pollution and Poor Cardiac Autonomic Control in the Elderly. *Environ. Health Perspect.* 107: 521-525.

Long, R.W., Thompson, W., Eatough, N.L., Eatough, D.J., Pope, C.A., Wilson, W.E., 2001. The Salt Lake City EPA EMPACT Program: I. Sampling Plan and Early Data. *Proceedings, A&WMA 93rd Annual Conference & Exhibition.*

MacGregor, J.T., Claxton, L.D., Lewtas, J., Jensen, R., Lower, W.R., and Pesch, G.G., (1994). Monitoring environmental genotoxicants. *Methods of Genetic Risk Assessment*, 171-243.

Mignacca, D., Stubbs, K., (1999). Effects of Equilibration temperature on PM10 Concentrations from the TEOM Method in the Lower Fraser Valley. *J. Air & Waste Manage. Assoc.* 49: 1250-1254.

Patashnick, H., Rupprecht, E. G., (1991). Continuous PM10 measurements using the tapered element oscillating microbalance. *J. Air & Waste Manage. Assoc.* 41: 1079-1083.

Pope C.A. III, Verrier R.L., Lovett E.G., Larson A.C., Raizenne, M.E., Kanner R.E., Schwartz, J., Villegas, G.M., Gold, D.R., Dockery, D.W., (1999a). Heart Rate Variability Associated with Particulate Air Pollution. *Amer. Heart J.* 138: 890-899.

Pope C.A. III, Dockery D.W., Kanner, R.E., Villegas, G.M. Schwartz, J., 1999b. Oxygen Saturation, Pulse Rate, and Particulate Air Pollution: A Daily Time-Series Panel Study. *Amer. J Resp. Cirt Care Med.* 159, 365-372.

- Pope, C.A. III, 2000. Epidemiology of fine particulate air pollution and human health; Biological mechanisms and who's at risk? *Environ. Health Perspect* 108(Sup 4): 713-723.
- Pope, C.A. III, Eatough, D.J., Gold, D.R., Nielson, K.R., Leininger, L., Nath, P., Modey, W.K., Kanner, R.E. (2004) Heart Rate Variability and Blood Markers of Inflammation in a Panel of Elderly Subjects. *Environ. Health Perspect.* 3: 339-345.
- Schaefer, G., Hamilton, W., Mathai, C.V., 1997. Implementing the revised NAAQS and the FACA subcommittee for ozone, particulate matter and regional haze. *Environ. Manager.* 22-28.
- Schwartz, J., Dockery, D.W., Neas, L.M., (1996). Is daily mortality associated specifically with fine particles? *J. Air & Waste Manage. Associat.* 46:927-939.
- Tang, H., Lewis, E. A., Eatough, D. J., Burton, R. M., and Farber, R. J. (1994). Determination of the particle size distribution and chemical composition of semi-volatile organic compounds in atmospheric fine particles. *Atmos. Environ.* 28: 939-947.
- Task Force of the European Society of Cardiology and the North American Society of Pacing and Electrophysiology. (1996). Heart Rate Variability: Standards of Measurement, Physiological Interpretation, and Clinical Use. *Circulation* 93: 1043-1065.
- Turpin, B.J., and Lim, H.J. (2001). Species Contributions to PM_{2.5} Mass Concentrations: Revisiting Common Assumptions for Estimating Organic Mass. *Aerosol Sci. Technol.* 35: 602-610.
- Walsh, D., Warren, S., Zweidinger, R., Claxton, L., Lewtas, J., (1993). Mutagenicity of indoor and outdoor air in Boise, Idaho and Roanoke, Virginia. Proc. EPA/APCA Symposium on Measurement of Toxic and Related Pollutants, Air Pollution Control Association, 190-196.

Chapter 10. Conclusions and Recommendations for Further Research

10.1. Overview

The accurate determination of all components of ambient $PM_{2.5}$ is important because of observed adverse effects on health, visibility, and global radiative balance. Because a significant portion of $PM_{2.5}$ has been shown to be semi-volatile (Eatough *et al.*, 2001; Long *et al.*, 2002; Long *et al.*, 2003), and semi-volatile material (SVM) may be important in cardiovascular human health effects (Pope *et al.*, 2000; Pope *et al.*, 2004), the development of instruments to accurately measure the semi-volatile fraction of $PM_{2.5}$ is essential. Single filter methods, such as the $PM_{2.5}$ FRM, can accurately measure stable species such as sulfate, and trace and crustal elements (Musick, 2000) but cannot accurately determine semi-volatile fine particulate species such as ammonium nitrate and semi-volatile organic material (SVOM) (Eatough *et al.*, 2003, Hering and Cass, 1995).

Several integrated samplers have been developed that accurately determine nonvolatile material (NVM) and SVM concentrations including a modified speciation sampler (Carter *et al.*, 2002) and the particle concentrator-Brigham Young University organic sampling system, PC-BOSS, (Tang *et al.*, 1994; Sioutas *et al.*, 1994; Ding *et al.*, 2002a; Modey *et al.*, 2001; 2002; Ding *et al.*, 2002b; Lewtas *et al.*, 2001). Although these samplers can accurately speciate $PM_{2.5}$, including SVM, there are several drawbacks. Integrated samplers are very labor and cost intensive. Collection of filter media and in-lab analysis are time-consuming and expensive, resulting in data interpretation weeks and months from the time of collection. The potential for sample contamination is increased with collection, transport, and laboratory analysis. Furthermore, 1-h time resolved data is often not possible with integrated samplers which

inhibits the ability to temporally resolve short term changes in pollution levels that often occur in urban environments.

To overcome these problems, the development of real-time or near real-time instruments has been attempted. One of the most universally used real-time $PM_{2.5}$ measurement techniques is the Tapered Element Oscillating Microbalance (TEOM) developed by Rupprecht & Patashnick. The TEOM does not accurately determine total $PM_{2.5}$ mass because the particle collection filter is heated to 30 - 50 °C to remove particle bound water which also results in loss of SVM. The real-time ambient mass sampler (RAMS) has been shown to measure total $PM_{2.5}$ concentrations, including SVM (Eatough, *et al.*, 2001; Obeidi and Eatough, 2002; Pang *et al.*, 2002; Long *et al.*, 2002; Grover *et al.*, 2005; Eatough *et al.*, 2003). However, this instrument is not sufficiently easy to use for routine field analysis.

10.2. Conclusions and Recommendations for Further Research

To overcome the deficiency in the ability to accurately measure all the major components of $PM_{2.5}$, several semi-continuous instruments were validated and developed to accurately measure $PM_{2.5}$ mass and chemical components, as discussed in this dissertation.

Studies conducted in Lindon, UT (Chapter 3), Rubidoux, CA (Chapter 4), and Fresno, CA (Chapter 6), indicated that the FDMS can accurately measure total $PM_{2.5}$ concentrations including semi-volatile species. The FDMS TEOM was validated by comparisons with the PC-BOSS, an integrated sampler, and the RAMS, a continuous sampler, both of which have been shown to accurately measure both nonvolatile and semi-volatile $PM_{2.5}$. The FDMS TEOM can easily be deployed in the field for routine

analysis with little operator supervision. The differential TEOM and GRIMM monitors also measure total $PM_{2.5}$, including the SVM as shown in studies conducted in Rubidoux and Fresno, CA. In contrast, neither the conventional heated TEOM monitor nor the heated GRIMM monitor measure semi-volatile particulate matter. The FDMS TEOM and differential TEOM monitors do not measure fine particulate water content because of the use of Nafion dryers. However, the conventional GRIMM monitor may respond to particle bound water under conditions of high %RH.

In studies conducted in Fresno, CA (Chapter 6), the FDMS TEOM, BAMS, differential TEOM, and conventional GRIMM monitor all were relatively equivalent except during episodes of high $PM_{2.5}$ concentrations that often occurred during foggy nighttime conditions. SVM during these time periods was often influenced by high concentrations of SVOM. The observed small peak concentration variance between the different real-time measurement techniques may be associated with the complexity of the aerosol being measured, including water content and SVM composition. However, a definitive explanation is not known at this time. Further investigation of the effect of SVM composition, especially SVOM, on real-time mass measurement is needed. When differences were observed, agreement with the PC-BOSS results was best for the FDMS TEOM.

Comparisons were made with 24-h averaged FDMS monitor results and 24-h FRM data in Rubidoux, CA (Chapter 4) and Fresno, CA (Chapter 6). Under the sampling conditions observed in Rubidoux, CA, the FRM underestimated $PM_{2.5}$ concentrations by approximately 32%. The combination of partial loss of ammonium nitrate and SVOM during sampling with the single filter FRM was shown to account for

the under-measurement of $PM_{2.5}$ mass measured by the FRM. Under the cold and humid ambient conditions observed in Fresno, CA when FRM samples were obtained, the 24-h averaged FDMS measurements were in agreement with FRM measurements of $PM_{2.5}$. However the agreement between these two samplers can be explained. During three sampling periods, lower $PM_{2.5}$ concentrations were observed with little or no SVM present in the aerosol. These three sampling days were also impacted by intermittent rain resulting in the observed low concentrations of $PM_{2.5}$. The other two sampling periods, when the aerosol had significant concentrations of SVM, cold and humid conditions were observed which has been shown to stabilize SVM collected on the filter of the FRM (Long *et al.*, 2003).

The inorganic fraction (i.e., sulfate, nitrate and ammonium ion) of ambient $PM_{2.5}$ can routinely be measured with either the TTU prototype instrument or the Dionex GP-IC. Excellent agreement was observed between TTU prototype and/or GP-IC measurements with 3-h integrated PC-BOSS samples collected in Lindon, UT (Chapter 3), and Fresno, CA (Chapter 6). For nitrate measurements, the Dionex GP-IC proved more reliable at accurately measuring nitrate than the R&P nitrate monitor, especially under high percent relative humidity (RH%) conditions. Under high RH%, the R&P monitor may be influenced by matrix effects and/or incomplete flash volatilization (Long and McClenny, 2004).

The modification of a Sunset monitor, and the development of a dual-oven Sunset monitor, has allowed for the semi-continuous measurement of both nonvolatile and semi-volatile carbonaceous material as shown in Chapters 7 and 8. In studies conducted in Rubidoux, CA (Chapter 4) and Riverside, CA (Chapter 8), good agreement was

observed between total carbon ($TC = EC + NVOM + SVOM$) measured with 3-h integrated PC-BOSS samples and the modified and dual-oven Sunset monitors. However, some blank measurement concerns still exist that warrant further investigation.

A suite of instruments has been suggested (Chapter 8) for the semi-continuous measurement of all the major chemical components of ambient $PM_{2.5}$ including both nonvolatile and semi-volatile species. Inorganic particulate sulfate and nitrate can be measured by an IC based aerosol sampling instrument (i.e., TTU prototype instrument or Dionex GP-IC). A dual-oven Sunset carbon monitor can be employed to measure NVOM, EC, and SVOM with a 1-h time resolution. Semi-continuous mass closure of the major components of ambient fine particulate material was obtained for the first time during July-August 2005 in Riverside, CA using the aforementioned semi-continuous instruments. Constructed mass concentrations showed good agreement with the FDMS measured mass with an observed uncertainty less than the propagation of error estimated uncertainty. The semi-continuous measurement of the major components of $PM_{2.5}$ will be a benefit to State and local regulatory agencies, allowing the temporal resolution of $PM_{2.5}$ species in urban atmospheres. Short-term temporal resolution of the major species of $PM_{2.5}$ will allow for better forecasting of $PM_{2.5}$ episodes and may lead to increased understanding of related health effects. Furthermore, mass closure can be obtained on a 1-h time basis which may increase the power of source apportionment methods to more accurately identify sources of ambient $PM_{2.5}$.

One deficiency in the suite of instruments suggested for mass closure is the measurement of $PM_{2.5}$ crustal material or metals. Further research needs to focus on a routine field instrument for the semi-continuous quantitative analysis of $PM_{2.5}$ metal

concentrations to be coupled with the semi-continuous instruments evaluated in this dissertation. These types of experiments are in the planning stages at BYU. At this time only one major sampling campaign in Riverside, CA has been performed using this suite of instruments to measure all the major components of $PM_{2.5}$. Further field validation is needed in other locations where the composition of the measured aerosol may be significantly different than that measured in Riverside, CA.

The advantage of using semi-continuous sampler data in the application of source apportionment is evident in the results given in this dissertation, as shown in Chapters 3 and 5. Local aerosols are often impacted by short-term pollution episodes that cannot be temporally resolved using integrated samplers. One-h averaged data applied to source apportionment models may increase the power of the model to predict sources that exhibit diurnal short-term episodes. Two different source apportionment methods were used in this dissertation, including EPA UNMIX (Chapter 3) and PMF2 (Chapter 5), to identify sources of both primary emissions and secondary processes. However, these methods use different models to deduce factors from the input data. If source apportionment methods are to be routinely used by State and regulatory agencies, further investigation is needed to compare and contrast the strengths and weaknesses of these models. The semi-continuous measurement of more ambient chemical species that can be related to sources would also further increase the strength of these models to predict specific sources. The development of a gas chromatography - mass spectrometry (GC-MS) instrument is underway at BYU for the semi-continuous measurement of specific organic marker compounds. This should significantly aid in the identification of factors deduced by receptor models.

The set-up and design of a controlled human exposure chamber has been discussed (Chapter 9). Facilities at Brigham Young University include a collapsible 30 m³ Teflon bag connected to a controlled exposure study chamber via a dedicated recirculating system. This chamber has been developed and characterized with wood smoke emissions for controlled human exposure studies to determine health effects related to specific sources and composition of PM_{2.5} pollutants. In recent studies, health effects data including changes in heart rate, heart rate variability, and markers of blood inflammation have been obtained for elderly individuals near ambient monitoring sites (Pope *et al.*, 2004). These studies include the detailed chemical composition and sources of ambient PM_{2.5} at a central monitoring site (Long *et al.*, 2003). Potential weak links in these and similar ambient health effects studies are that no personal exposure data for each participant in the studies are obtained because experimental techniques do not allow for the facile determination of personal exposure to the wide variety of PM_{2.5} components. Therefore, validation of implied health effects by controlled exposure studies would be valuable. Further characterization of other atmospherically relevant aerosols (i.e., mobile source emissions and concentrated ambient particles) would be useful in human exposure studies. These, or similar, controlled exposure studies may aid in the identification of specific aerosol components that lead to human cardiovascular and respiratory health effects.

10.3. References

Carter, C., Long, R. W., Eatough, N. L., and Eatough D. J., (2002). Comparison of Speciation Sampler and PC-BOSS PM_{2.5} Organic Material Results Obtained on the Wasatch Front During the Winter of 2001-2002. *Pro. AWMA 2002 Annual Conf.* 767.

Ding, Y., Pang, Y., Eatough, D.J., Eatough, N.L., and Tanner, R.L. (2002a). High-Volume Diffusion Denuder Samplers for the Routine Monitoring of Fine Particulate Matter: I. Design and Optimization of the PC-BOSS. *Aerosol Sci. Technol.* 36: 369-382.

Ding, Y., Pang, Y., Eatough, D.J., Eatough, N.L., and Tanner, R.L. (2002b). High-Volume Diffusion Denuder Samplers for the Routine Monitoring of Fine Particulate Matter: II. Field Evaluation of the PC-BOSS. *Aerosol Sci. Technol.* 36: 383-396.

Eatough, D.J., Eatough, N.L., Obeidi, F., Pang, Y., Modey, W., and Long, R. (2001) Continuous determination of PM_{2.5} mass, Including Semi-Volatile Species. *Aerosol Sci. Technol.* 34: 1-8.

Eatough, D.J., Long, R.W., Modey, W.K., Eatough, N.L. (2003). Semi-Volatile Secondary Organic Aerosol in Urban Atmospheres: Meeting a Measurement Challenge. *Atmos. Environ.* 37: 1277-1292.

Grover, B.D., Kleinman, M., Eatough, N.L., Eatough, D.J., Hopke, P.K., Long, R.W., Wilson, W.E. Meyer, M.B., Ambs, J.L., (2005). Measurement of total PM_{2.5} mass (nonvolatile plus semi-volatile) with the FDMS TEOM monitor. *J. Geophys. Res.* Vol. 110: D07S03.

Hering, S.; Cass, G. (1995). The Magnitude of Bias in the Measurement of PM_{2.5} Arising from Volatilization of Particulate Nitrate from Teflon Filters. *J. Air & Waste Manage. Assoc.* 49: 725-733.

Lewtas, J., Booth, D., Pang, Y., Reimer, S, Eatough, D.J., and Gundel, L. (2001). Comparison of sampling methods for semi-volatile organic carbon (SVOC) associated with PM_{2.5}. *Aerosol Sci. Technol.* 34: 9-22.

Long, R.W., Smith, R., Smith, S., Eatough, N.L., Mangelson and Eatough, D.J. (2002) Sources of Fine Particulate Material along the Wasatch Front, *Energy and Fuels.* 16: 282-293.

Long, R. W., Eatough, N. L., Mangelson, N. F., Thompson, W., Fiet, K., Smith, S., Smith, R., and Eatough, D. J., (2003). The Measurement of PM_{2.5}, Including Semi-Volatile Components, in the EMPACT Program: Results from the Salt Lake City Study and Implications for Public Awareness, Health Effects, and Control Strategies, *Atmos. Environ.* 37: 4407-4417.

Modey, W. K., Pang, Y., Eatough, N. L., and Eatough, D. J., (2001) Fine Particulate (PM_{2.5}) Composition in Atlanta, USA: Assessment of the Particle Concentrator Brigham Young University Organic Sampling System, PC-BOSS, During the EPA Supersite Study, *Atmos. Environ.* 35, 6493-6502.

Modey, W. K., Eatough, D. J. (2002). Trends in Composition at the Department of Energy OST NETL PM2.5 Characterization Site in Pittsburgh, Pennsylvania, USA. *Adv. Environ. Res.*, in press.

Musick, D. (2000) A Summary of the Ambient Air Program for PM2.5 *Environ. Manager.* 17-20.

Obeidi, F., Eatough, D.J. (2002). Continuous Measurement of semivolatile fine particulate mass in Provo, UT. *Aerosol Sci. Technol.* 36: 191-203.

Pang, Y., Eatough, N.L., Modey, W.K., Eatough, D.E., (2002). Evaluation of the RAMS continuous monitor for determination of PM2.5 mass including semi-volatile material in Philadelphia, PA. *J. Air Waste Manage. Assoc.* 52:563-572.

Pope, C.A. III (2000). Epidemiology of fine particulate air pollution and human health; Biological mechanisms and who's at risk? *Environ. Health Perspect.* 108(Sup 4): 713-723.

Pope, C. A. III, Hansen, M. L., Long, R. W., Nielson, K. R., Eatough, N. L., Wilson, W. E., Eatough, D. J. (2004). Particulate Air Pollution, HRV, and Inflammation. *Environ. Health Perspect.* 112: 339-345.

Sioutas, C., Koutrakis, P., and Burton, R.M. (1994). Development and Evaluation of a Low Cutpoint Virtual Impactor. *Aerosol Sci. Technol.* 21: 223-235.

Tang, H., Lewis, E. A., Eatough, D. J., Burton, R. M., and Farber, R. J. (1994). Determination of the particle size distribution and chemical composition of semi-volatile organic compounds in atmospheric fine particles. *Atmos. Environ.* 28: 939-947.